

REV.	DATE	DESCRIPTION
NC	05/10/04	INITIAL RELEASE

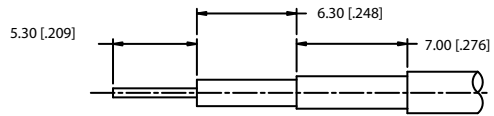

RECOMMENDED CABLE STRIPPING DIMENSIONS

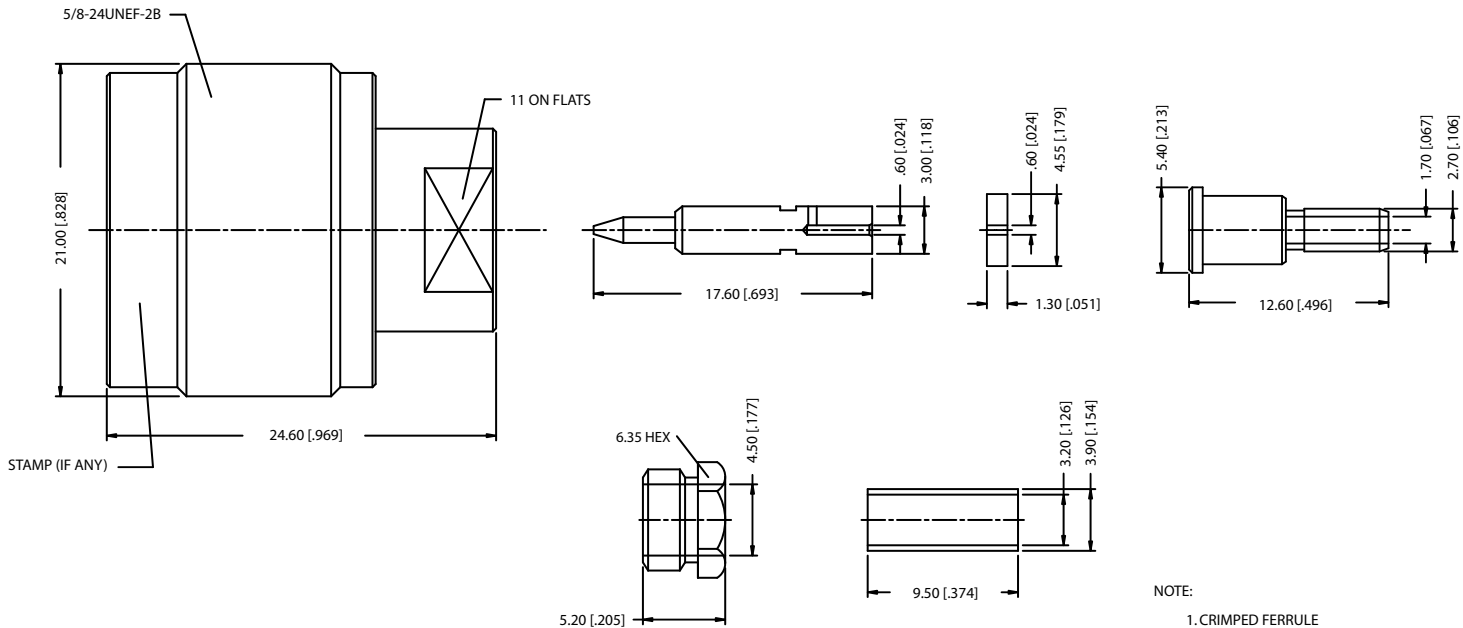

- NOTE:
1. CRIMPED FERRULE
HEX CRIMP SIZE .128"
 2. CRIMPED CONTACT PIN
HEX CRIMP SIZE .100"

8				
7				
6	FERRULE	COPPER	NEXCOTE	1
5	HEX NUT	BRASS	NEXCOTE	1
4	BARREL	BRASS	NEXCOTE	1
3	CONTACT PIN	BRASS	GOLD	1
2	INSULATOR	TEFLON	NATURAL	2
1	SHELL/BODY	BRASS	NEXCOTE	1
	DESCRIPTION	MATERIAL	FINISH	QTY

UNLESS OTHERWISE SPECIFIED DIMENSIONS ARE IN MILLIMETERS, DIMENSIONS IN [] ARE IN INCHES AND FOR CUSTOMER REFERENCE ONLY.

UNLESS OTHERWISE SPECIFIED TOLERANCES FOR MILLIMETERS ARE:

0.5 - 8mm ± 0.20mm
8 - 30mm ± 0.40mm
30 - 120mm ± 0.50mm

UNLESS OTHERWISE SPECIFIED TOLERANCES FOR INCHES ARE:

.020 - .315 ± 0.007"
.315 - 1.180 ± 0.015"
1.180 - 4.724 ± 0.020"

DO NOT SCALE DRAWING

APPROVALS	DATE
DRAWN G.R.S.	05/10/04
CHECKED	
ISSUED	
SHEET 1 OF 1	
CAD FILE	C:/172/172128.DWG

<h1>Amphenol - Connex</h1>		PART DESCRIPTION			
		<p>N CRIMP PLUG (FOR RG-174/U, 188A/U, 316/U)</p>			
PART NO.		172128			
DWG. NO.	172128.DWG	REV.	NC	SIZE	A
		SCALE	NA		