

REV.	DATE	DESCRIPTION
A	05/24/04	UPDATE DRAWING FORMAT

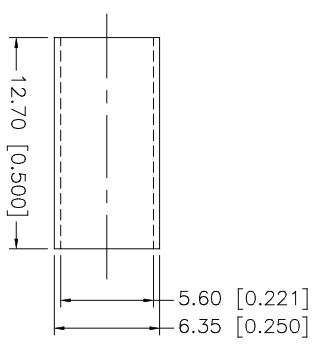
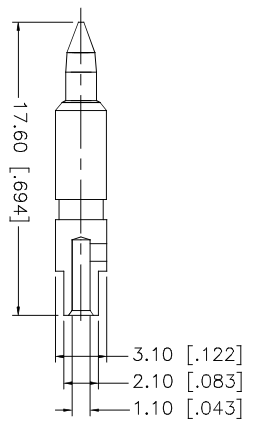
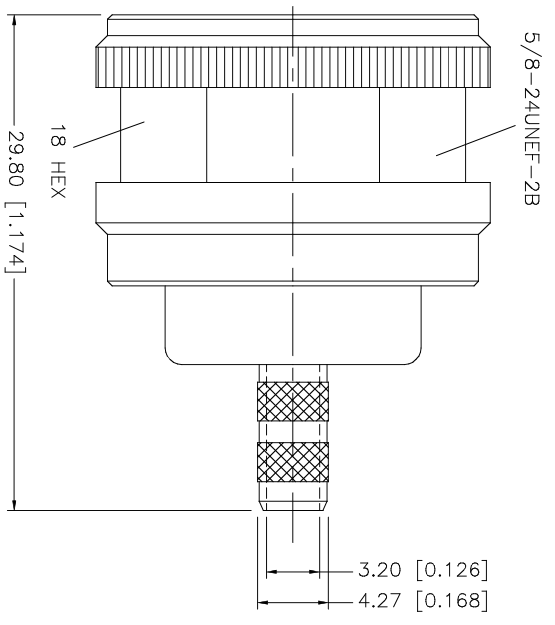
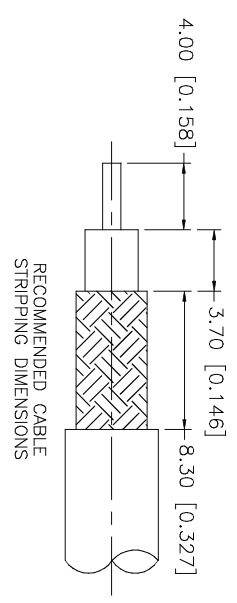

CRIMP NOTES:

1. CRIMPED FERRULE
HEX CRIMP SIZE ".213"
2. CRIMPED CONTACT PIN
HEX CRIMP SIZE ".068"

QTY	FINISH	MATERIAL	DESCRIPTION
1	NEXCOTE	BRASS	FERRULE
1	GOLD	BRASS	CONTACT PIN
1	RED	SILICON	GASKET
1	NATURAL	TEFLON	INSULATOR
1	NEXCOTE	BRASS	BARREL
1	NEXCOTE	BRASS	BODY

UNLESS OTHERWISE SPECIFIED, DIMENSIONS ARE IN MILLIMETERS DIMENSIONS IN INCHES ARE FOR CUSTOMER REFERENCE ONLY.	UNLESS OTHERWISE SPECIFIED, DIMENSIONS FOR MILLIMETERS ARE:	UNLESS OTHERWISE SPECIFIED, DIMENSIONS FOR INCHES ARE:
	0.3 - 8mm ± 0.20mm	.020 - .315 ± ± 0.007"
	8 - 30mm ± 0.40mm	.315 - 1.180 ± ± 0.015"
	30 - 120mm ± 0.50mm	1.180 - 4.724 ± ± 0.020"

APPROVALS	DATE
DRAWN G.R.S.	05/24/04
CHECKED	
ISSUED	
SHEET 1 OF 1	

PART NO.	DWG. NO.	REV.	SIZE	SCALE
172142-11	172142-11.DWG	A	A	NA

Amphenol Connex

N CRIMP PLUG
(FOR RG-55/U, 142A/U, 223/U, 400/U CABLE)