

REV.	DATE	DESCRIPTION
NC	04/29/04	INITIAL RELEASE

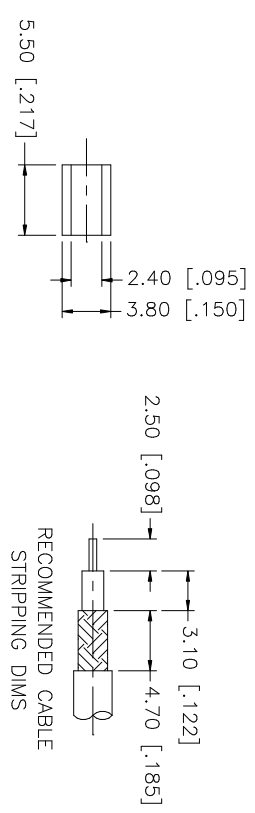
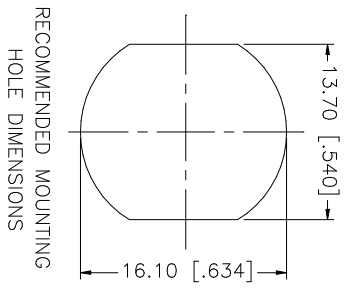
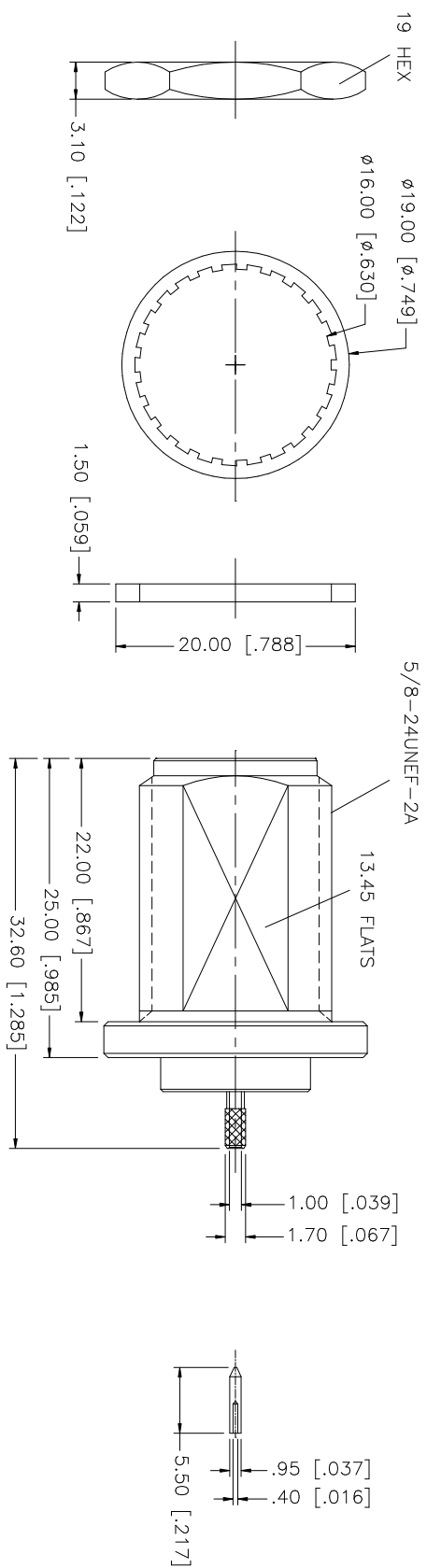

NOTE:
 1. CRIMPED FERRULE
 HEX CRIMP SIZE .128"
 2. MAX. PANEL THICKNESS = 6.5mm

QTY	FINISH	MATERIAL	DESCRIPTION
1	NEXCOTE	COPPER	FERRULE
1	NEXCOTE	BRASS	HEX NUT
1	NEXCOTE	BRASS	LOCK WASHER
1	RED	SILICONE	GASKET
1	GOLD	PHOS. BRONZE	CONTACT PIN
1	NATURAL	TEFLON	INSULATOR
1	NEXCOTE	BRASS	BODY
			DESCRIPTION

APPROVALS	DATE
DRAWN G.R.S.	04/29/04
CHECKED	
ISSUED	
SHEET 1 OF 1	

PART NO.	DESCRIPTION
172313	N BULKHEAD CRIMP JACK (FOR RG-178B/U, 196A/U CABLE)

DO NOT SCALE DRAWING	CAD FILE	DWG. NO.	REV.	SIZE	SCALE
	C:/172/172313.DWG	172313.DWG	NC	A	NA

Amphenol Connex