



Overview

The 18 GHz N-Type connector series is an expansion of the popular N-Type product line and offers all the same features and benefits with an extended frequency range. These connectors are designed to offer excellent low PIM performance in a reliable medium-sized package. The durable construction makes them ideal for rugged, outdoor applications which require faster data transmission rates.

18 GHz N-Type connectors feature the familiar threaded coupling mechanism for vibration resistance and low VSWR and insertion loss.

Features and Benefits

- Extended frequency range through 18 GHz
- Excellent low PIM Performance
- High power handling
- Ruggedized construction
- Threaded coupling mechanism ideal for vibration resistance

Applications

- Microwave
- Wireless Infrastructure
- Instrumentation
- Radar Systems
- Surge Protection
- Power Amplifiers
- Military
- Industrial

Ordering Information

Straight 18 GHz N-Type for RG-402 and 0.141" Semi-Rigid Cable

Part Number	Configuration	
082-6671	Straight 18 GHz N-Type Bulkhead Jack	
082-6672	Straight 18 GHz N-Type Jack	
082-6673	Straight 18 GHz N-Type Plug	

Amphenol RF

Four Old Newtown Road
Danbury, CT 06810

For more information visit: www.amphenolrf.com or
call 800.627.7100

Amphenol® RF

Technical Specifications

Electrical

Impedance	50 Ω	
Frequency Range	DC - 18 GHz	
VSWR(Return Loss)	1.2 Max @ 18 GHz	
Dielectric Withstanding Voltage	1500 VRMSMin	
PIM	-166 dBc @ 2X20W	
Insulation Resistance	5000 mΩ Min	
Contact Resistance	Center Contact	0.2 mΩ
	Outer Contact	0.2 mΩ

Environmental

Temperature Range	-65°C to +165°C
-------------------	-----------------

Mechanical

Mating	Threaded
Durability	500 Cycles Min.

Materials

Body	Brass, White Bronze Plating
Contact	Beryllium Copper, Silver Plating
Insulator	PTFE

Interface Dimensions

Plug

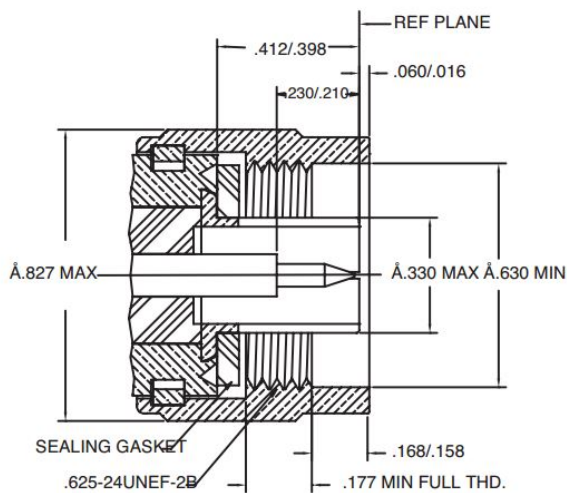

Jack

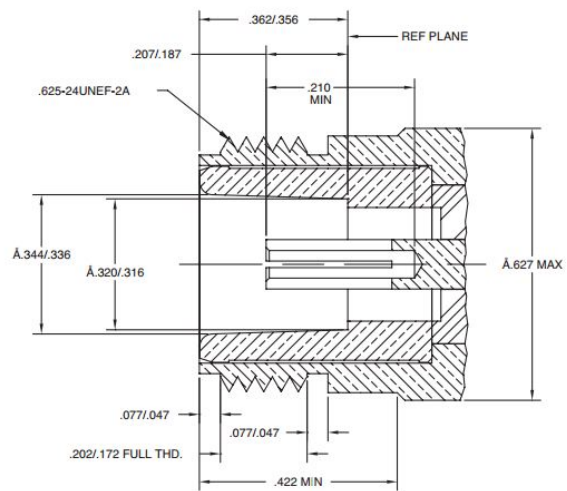

Amphenol RF

Four Old Newtown Road
Danbury, CT 06810

For more information visit: www.amphenolrf.com or
call 800.627.7100