

Distributed by:

JAMECO[®]
ELECTRONICS

www.Jameco.com ♦ 1-800-831-4242

The content and copyrights of the attached
material are the property of its owner.

Jameco Part Number 2057481

ELECTRICAL

	CECC22000	Test Requirement
Impedance		50 Ohm
Frequency Range		DC thru 6 GHz
VSWR <u>SMT and Edgecard</u> (Mated Pair) DC - 4 GHz 4-6 GHz <u>Cabled</u> Straight, Semi-Rigid Straight, Flex Right Angle, Semi-Rigid Right Angle, Flex	4.4.1	1.15 Max 1.40 Max 1.15 Max 1.20 Max 1.20 Max 1.25 Max
Dielectric Withstanding Voltage (at Sea Level)	4.4.5	500 V rms, 50 Hz
Working Voltage (at Sea Level)	4.4.4	≤170 V rms, 50 Hz
Insulation Resistance	4.4.4	≥500 MΩ
Contact Resistance Center Conductor Outer Conductor	4.4.2 4.4.3	≤10 mΩ ≤5 mΩ

NOTE: These characteristics are typical and may not apply to all connectors.

ENVIRONMENTAL

	CECC22000	Test Requirement
Temperature Range		-40°C thru 90°C
Temperature Shock	4.6.7	Mil-STD-202, Method 107
Humidity	4.6.6	Mil-STD-202, Method 103, Condition B
Vibration	4.6.3	3 cycles, 3 opposite directions, 10-150 Hz, 10-60 Hz: 0.75mm/.030 in., 60-150Hz 10G's
Mechanical Shock	4.6.4	Mil-STD-202, Method 213, Condition B

MECHANICAL

	CECC22000	Test Requirement
Engagement Force	4.5.4	≤3.4 lbs.
Disengagement Force	4.5.4	1.4 lbs. to 3.4 lbs.
Contact Captivation	4.5.2	2.3 lbs.
Durability (Machined)	4.7.1	≥500 cycles

MATERIAL

Connector Part	Standards	Material	Plating
Leads	QQ-C-530	BeCu	Gold
Contact Socket	QQ-C-530	BeCu	Gold
Outer Conductor	QQ-C-530	BeCu	Gold
Housing (SMT)	—	Liquid Crystal Polymer	—
Insulator	ASTM-D1457	PTFE	—

JACK

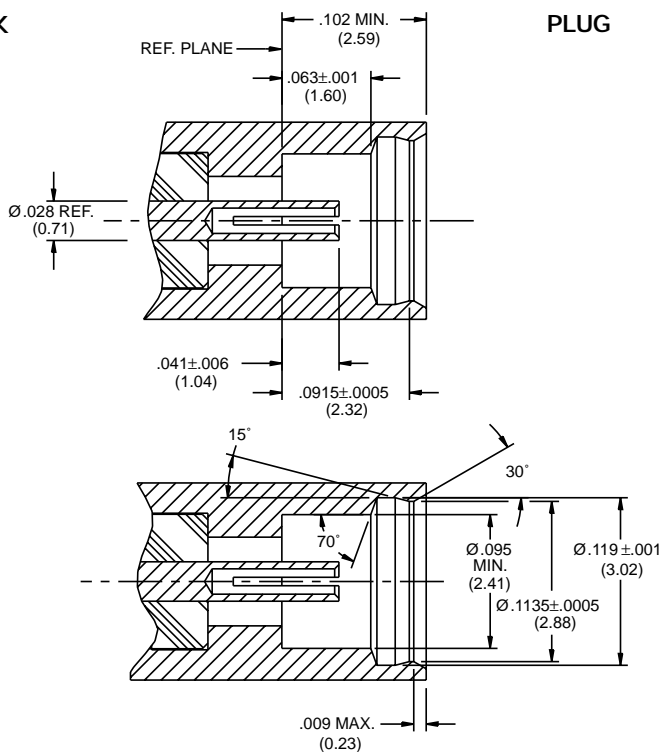

PLUG

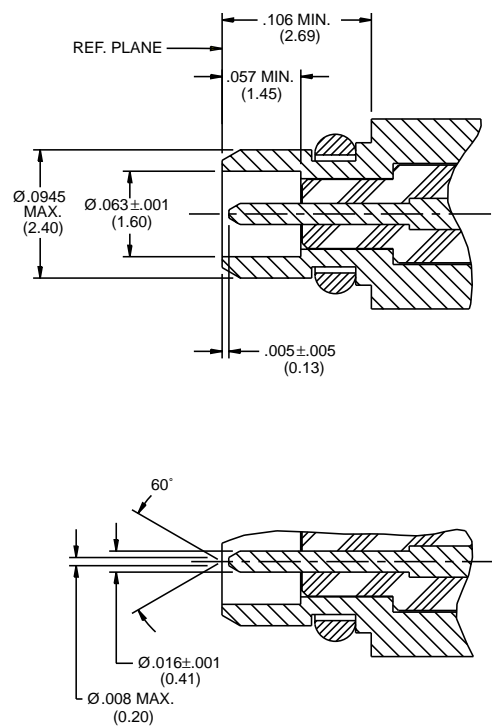

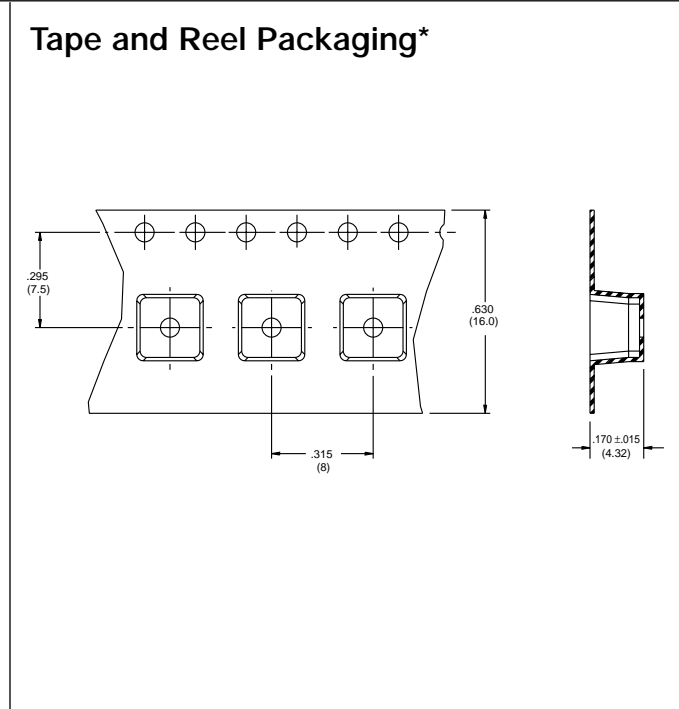
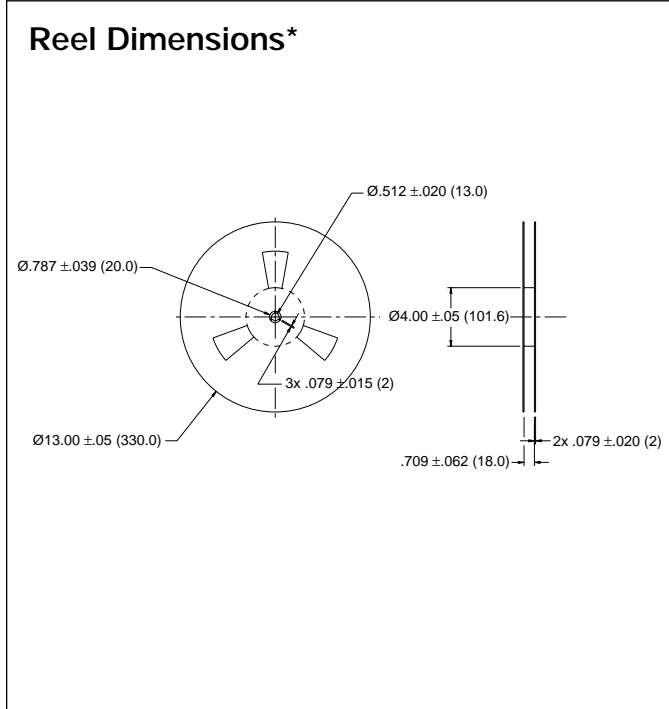
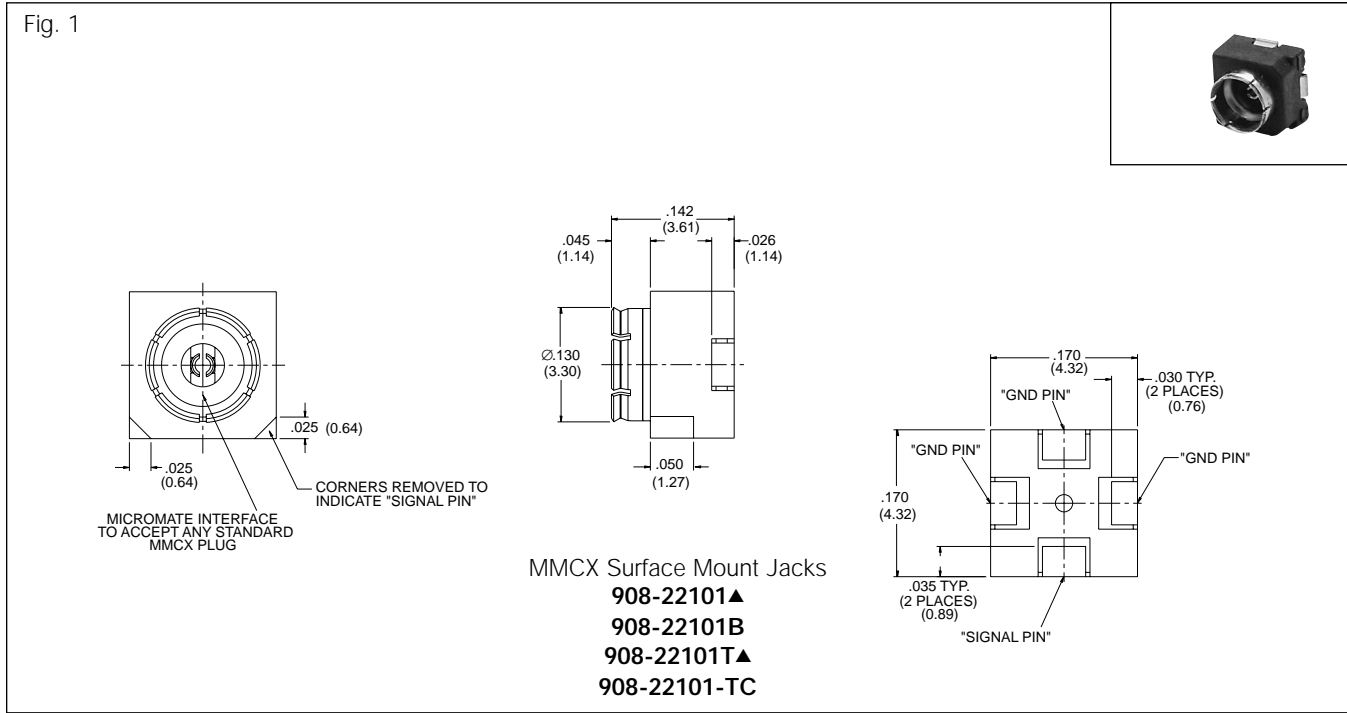

* Blister tape packaged uniformly for vertical mounting and supplied in accordance with IEC 286-3/EIA 481

MicroMate™ (MMCX) SURFACE MOUNTS

Description	Plt.	Ins.	Contact & Body	Mtg. Patterns/Page No.	Amphenol Number	Fig.
SMT Jack, Single Packed	P11	L1	Stamped Beryllium Copper	Fig. M3/8 or M4/8	▲ 908-22101	1
SMT Jack, Bulk Packed	P11	L1	Stamped Beryllium Copper	Fig. M3/8 or M4/8	908-22101B	1
SMT Jack, Tape & Reel	P11	L1	Stamped Beryllium Copper	Fig. M3/8 or M4/8	▲ 908-22101T	1
SMT Jack, Tape & Reel w/cap	P11	L1	Stamped Beryllium Copper	Fig. M3/8 or M4/8	908-22101-TC	1

▲ Distributor Stocked

Dimensions for Clearance and Mated Height

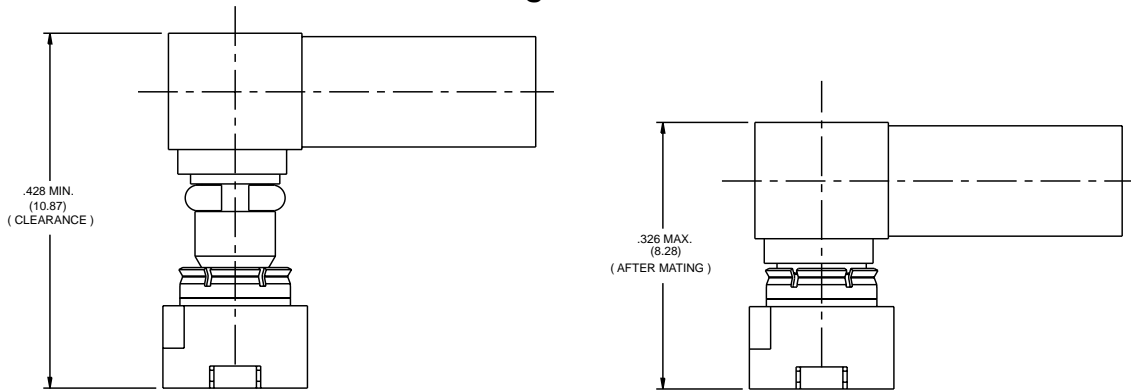

Pick and Place Automation

- Amphenol Surface Mount connectors can be assembled to printed circuit boards by state of the art pick and place equipment.
 - Connector pick-up by suction tip
 - Optional insertion tip (see illustration)

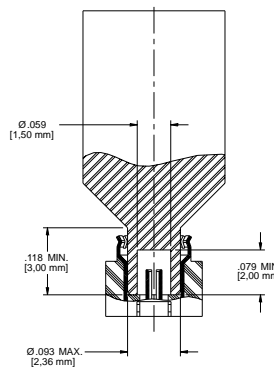

Application Notes

Amphenol SMT solder joints act as the mechanical bond to the printed circuit board and also functions as the point of electrical contact. With this in mind, the following points should be considered:

- Avoid forces from the cable of the mating connector to the surface mounted connector.
- For connecting and disconnecting of the surface mounted connector only non-axial forces should be applied. Non-compliance may cause excess torque and damage the solder connectors.

Recommended Mounting Patterns

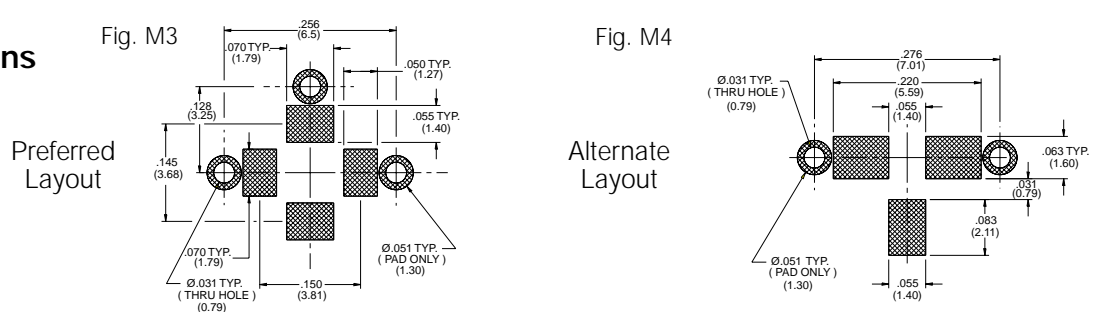

Soldering

MicroMate (MMCX) product is compatible with the following soldering methods.

- Infrared Soldering (Max 260°C/500°F)
- Vapor Phase Soldering (215°C/419°F)
- Normal Eutectic Solder Paste (63% tin, 37% lead)
- If stenciled or screened in accordance with the mounting patterns above

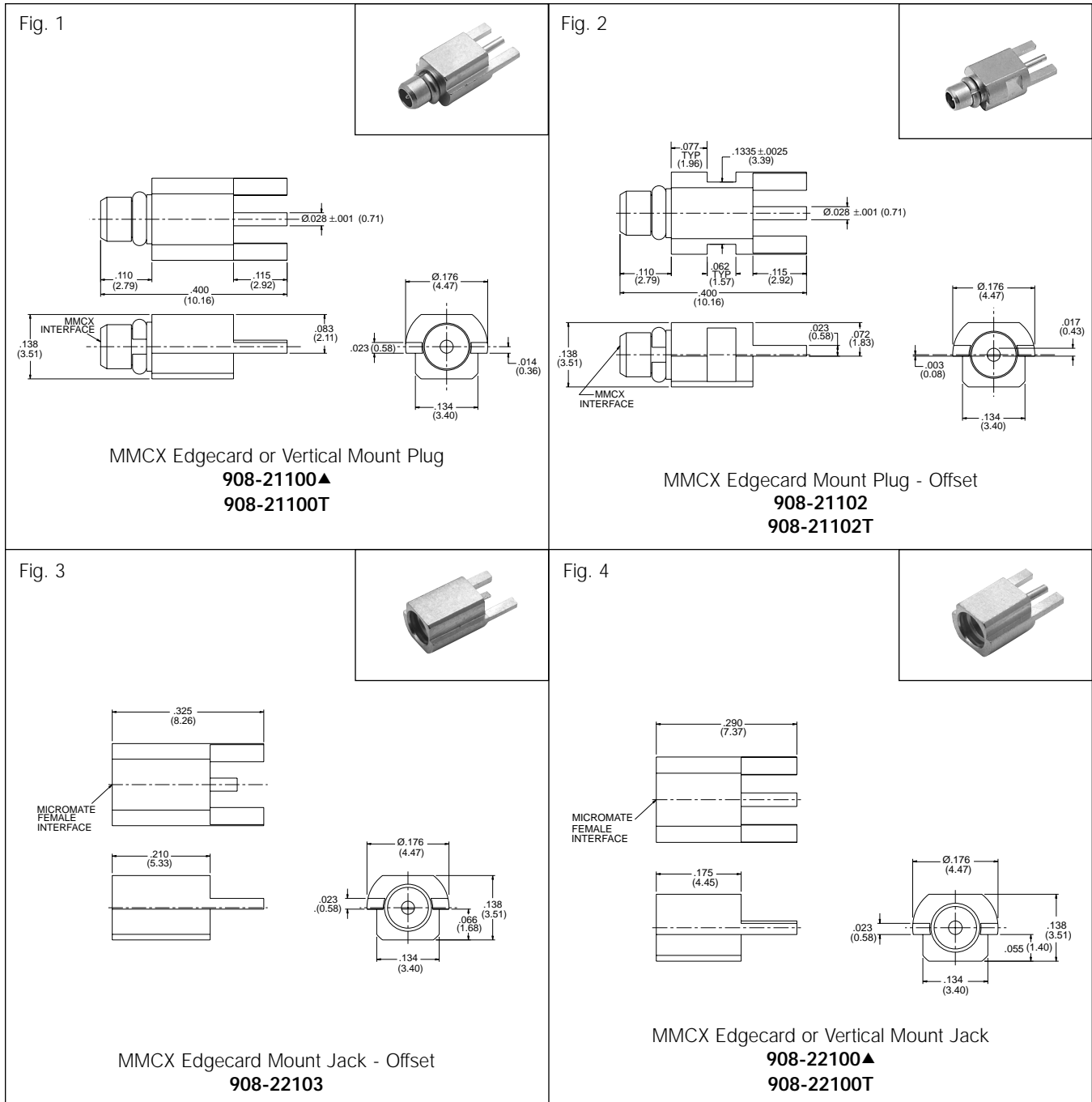

MicroMate™ (MMCX) EDGE CARD AND PCB MOUNTS

Description	Plt.	Ins.	Contact	Mtg. Patterns/Page No.	Construction Notes	Amphenol Number	Fig.
Edgcard Plug	P11	D1	Brass	Fig. M2/10 & M5/10	Machined	▲ 908-21100	1
Edgcard Plug, Tape & Reel	P11	D1	Brass	Fig. M2/10 & M5/10	Machined	908-21100T	1
Edgcard Plug, Offset	P11	D1	Brass	Fig. M5/10	Machined	908-21102	2
Edgcard Plug, Offset, Tape & Reel	P11	D1	Brass	Fig. M5/10	Machined	908-21102T	2
Edgcard Jack	P11	D1	BeCu	Fig. M2/10 & M5/10	Machined	▲ 908-22100	4
Edgcard Jack, Tape & Reel	P11	D1	BeCu	Fig. M5/10	Machined	908-22100T	4
Edgcard Jack - Offset	P11	D1	BeCu	Fig. M5/10	Machined	908-22103	3

▲ Distributor Stocked

Dimensions for Clearance and Mated Height

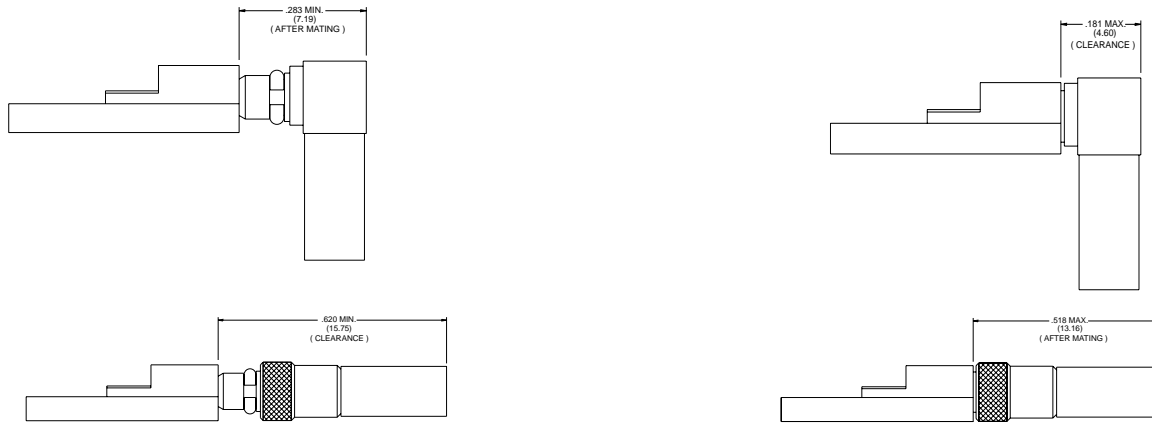

Pick and Place Automation

- Amphenol Edgecard Mount connectors can be assembled to PC boards with state of the art pick and place equipment.
 - Connector pick-up by suction tip

Application Notes

- Avoid radial forces from the cable of the mating connector to the surface mount connector
- Secure the cable sufficiently
- Apply only axial forces during mating and de-mating

Mounting Patterns

Fig. M1

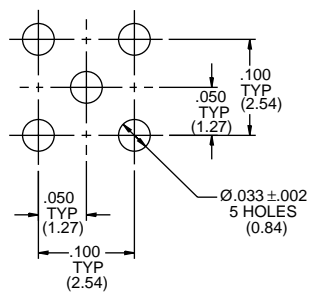
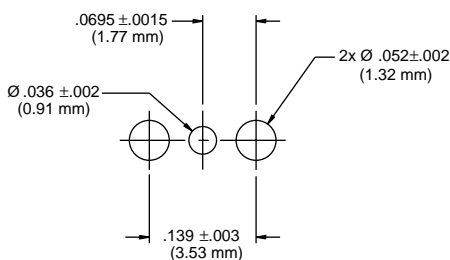
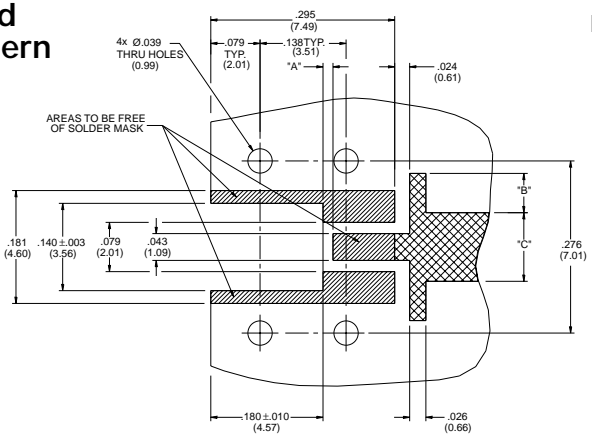

Fig. M2



Recommended Mounting Pattern

Fig. M5



Thickness (FR 4, Er=4.6)	"A"	"B"	"C"
.031 (0.79)	.039 (0.99)	-	.055 (1.40)
.039 (0.99)	.035 (0.89)	.012 (0.30)	.071 (1.80)
.063 (1.60)	.016 (0.41)	.063 (1.60)	.110 (2.79)

MicroMate (MMCX) product is compatible with the following soldering methods.

- Infrared Soldering (Max 260°C/500°F)
- Vapor Phase Soldering (215°C/419°F)
- Normal Eutectic Solder Paste (63% tin, 37% lead)
- If stenciled or screened in accordance with the mounting pattern above

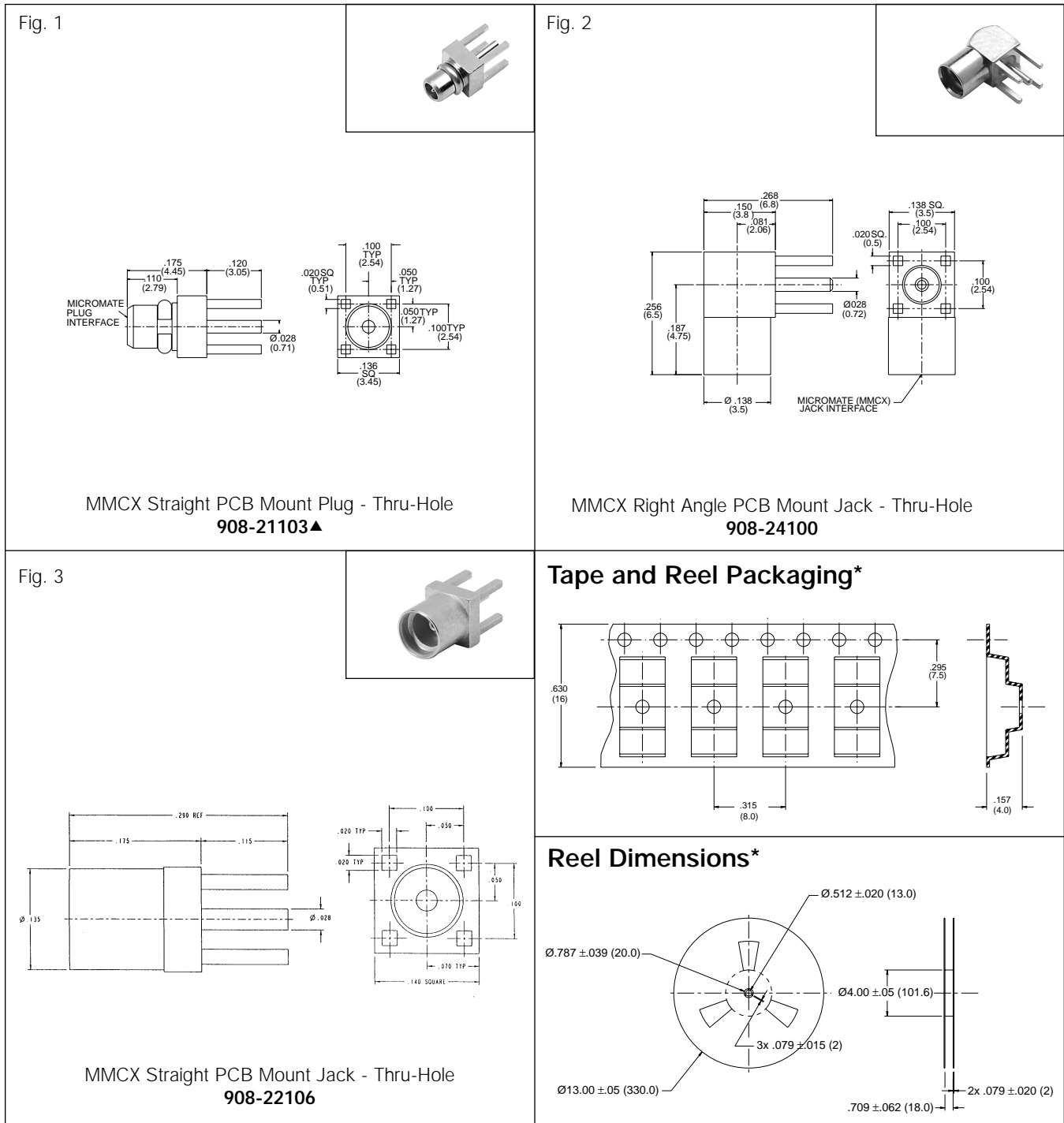

* Blister tape packaged uniformly for edgcard mounting and supplied in accordance with IEC 286-3/EIA 481

MicroMate™ (MMCX) EDGE CARD AND PCB MOUNTS

Description	Plt.	Ins.	Contact	Mtg. Patterns/Page No.	Construction Notes	Amphenol Number	Fig.
R/A Jack, PCB	P11	D1	BeCu	Fig. M1/6	1 Piece Contact	▲908-24100	2
Straight PCB Plug	P11	D1	Brass	Fig. M1/6	Machined	▲908-21103	1
Straight Jack PCB	P11	D1	BeCu	Fig. M1/6	Machined	▲908-22106	3

▲ Distributor Stocked

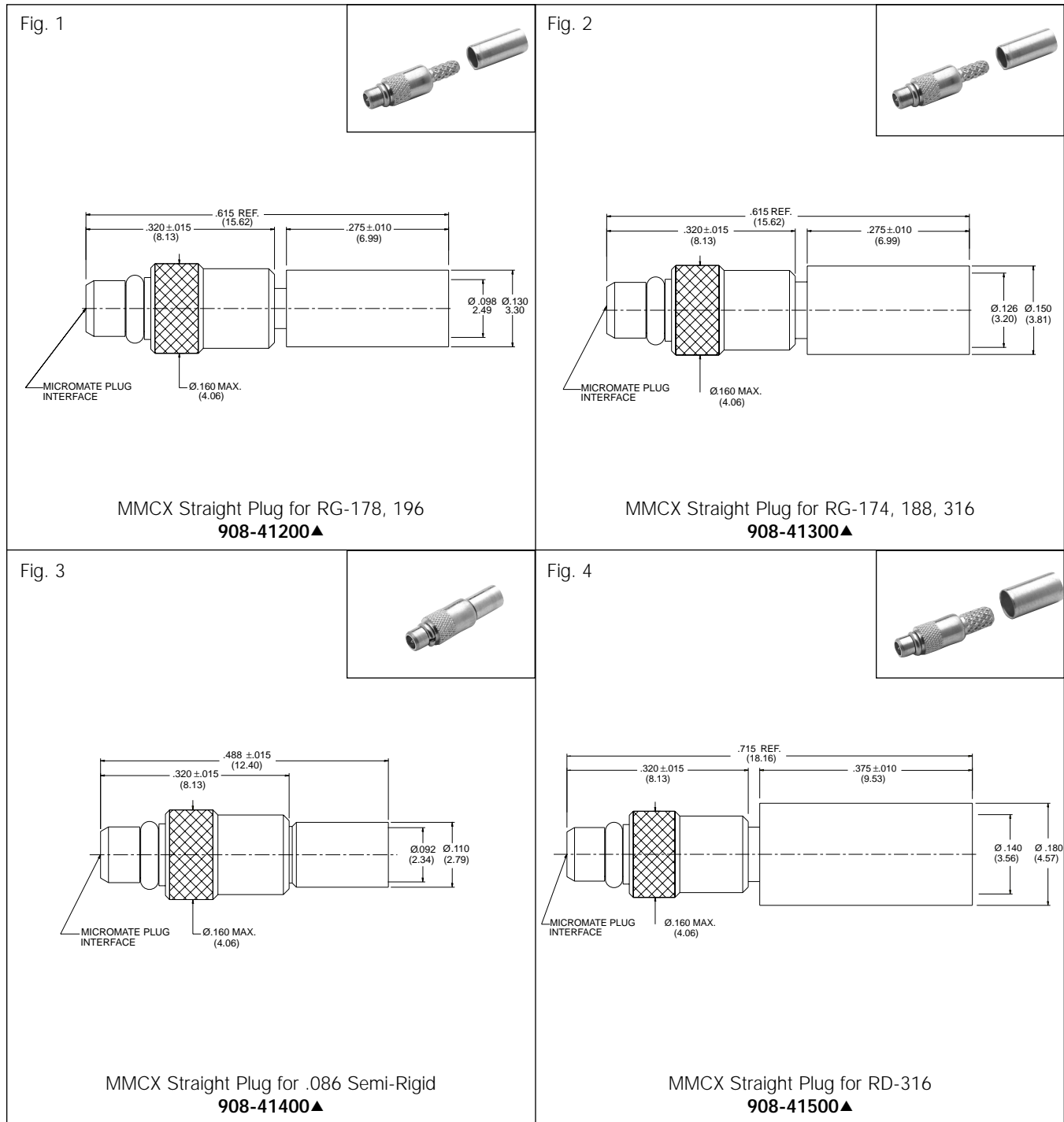

MicroMate™ (MMCX) CABLE CONNECTORS

Cable RG-/U	Cable Attachment		CAI	Plt.	Ins.	Construction Notes	Amphenol Number	Fig.
	Outer	Inner						
RG-178, 196	Crimp	Solder	C70	P11	D1	Captivated Contact	▲ 908-41200	1
RG-174, 188, 316	Crimp	Solder	C70	P11	D1	Captivated Contact	▲ 908-41300	2
.086 Semi-Rigid	Solder	Solder	C71	P11	D1	Captivated Contact	▲ 908-41400	3
RD-316	Crimp	Solder	C70	P11	D1	Captivated Contact	▲ 908-41500	4

▲ Distributor Stocked

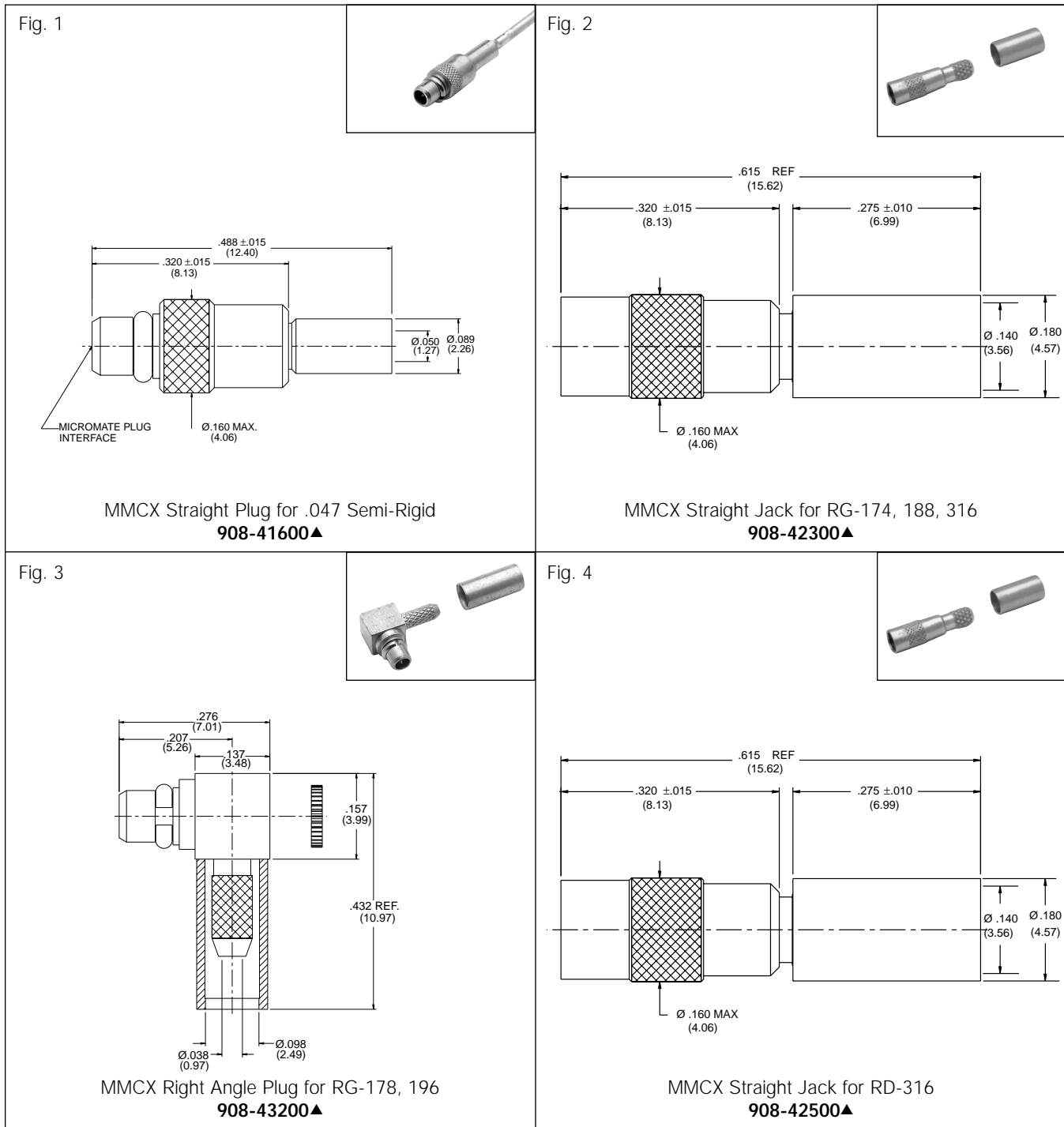

MicroMate™ (MMCX) CABLE CONNECTORS

Cable RG-/U	Cable Attachment		CAI	Plt.	Ins.	Construction Notes	Amphenol Number	Fig.
	Outer	Inner						
.047 Semi-Rigid	Solder	Solder	C71	P11	D1	Captivated Contact	▲ 908-41600	1
RG-174, 188, 316	Crimp	Solder	C70	P11	D1	Captivated Contact	▲ 908-42300	2
RG-178, 196	Crimp	Solder	C72	P11	D1	Captivated Contact	▲ 908-43200	3
RD-316	Crimp	Solder	C70	P11	D1	Captivated Contact	▲ 908-42500	4

▲ Distributor Stocked

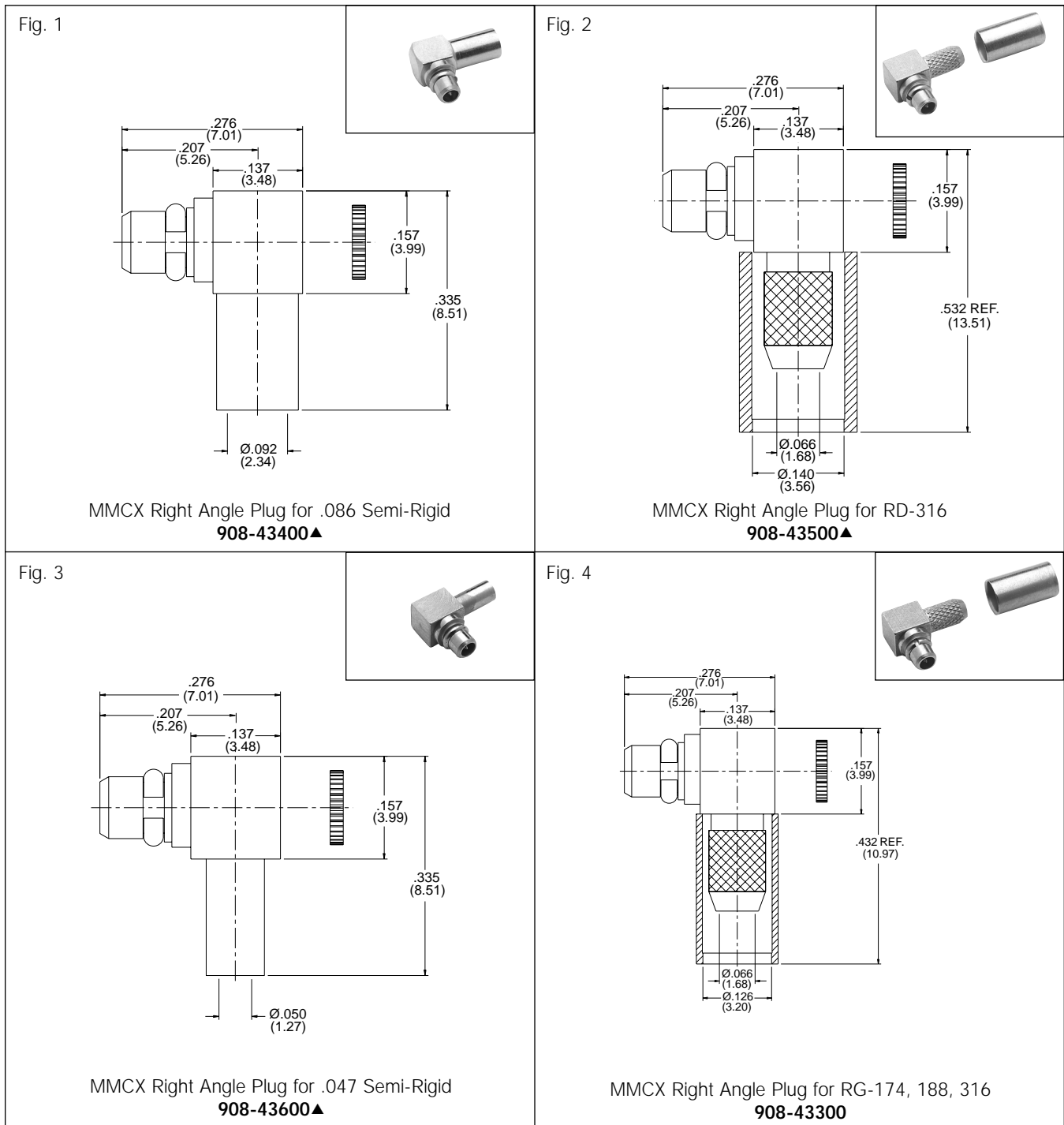

MicroMate™ (MMCX) CABLE CONNECTORS

Cable RG-/U	Cable Attachment		CAI	Plt.	Ins.	Construction Notes	Amphenol Number	Fig.
	Outer	Inner						
.086 Semi-Rigid	Solder	Solder	C73	P11	D1	Captivated Contact	▲ 908-43400	1
RD-316	Crimp	Solder	C72	P11	D1	Captivated Contact	▲ 908-43500	2
.047 Semi-Rigid	Solder	Solder	C73	P11	D1	Captivated Contact	▲ 908-43600	3
RG-174, 188, 316	Crimp	Solder	C72	P11	D1	Captivated Contact	▲ 908-43300	4

▲ Distributor Stocked

