

NOTES:

1. MATERIALS AND FINISHES:
 BODY - BRASS, GOLD PLATING
 CONTACT - BeCu, GOLD PLATING
 INSULATOR - PTFE, NATURAL
2. ELECTRICAL:
 A. IMPEDANCE: 50 OHM
 B. FREQUENCY RANGE: DC - 40 GHz
 C. VSWR (RETURN LOSS): 1.15:1 MAX (23 dB MIN) AT DC-10 GHz
 1.25:1 MAX (19 dB MIN) AT 10-26.5 GHz
 1.35:1 MAX (17 dB MIN) AT 26.5-40 GHz
 CONNECTOR ONLY, PERFORMANCE WILL VARY
 BASED ON BOARD LAYOUT
 D. DIELECTRIC WITHSTANDING VOLTAGE: 500 VRMS, MIN.
 E. INSULATOR RESISTANCE: 5000 MEGAOHMS MIN
 F. CONTACT RESISTANCE:
 CENTER CONTACT: 6 MILLIOHM, MAX
3. MECHANICAL:
 A. ENGAGEMENT FORCE: 2.5 LBS TYP.
 B. DISENGAGEMENT FORCE: 1.5 LBS TYP.
 C. CONTACT RETENTION: 1.5 LBS MIN AXIAL FORCE
 D. DURABILITY: 100 CYCLES MIN.
 E. TEMPERATURE RANGE: -65°C TO +165°C

4. PACKAGING:
 A. PACKAGE CONNECTOR IN TAPE AND REEL.
 B. QUANTITY: 2200 PCS / REEL
 C. MARKING: REEL TO BE MARKED
 "AMPHENOL RF, 925-169J-5IPT, AND DATE CODE"

THIRD ANGLE PROJ.

REVISIONS

REV	DESCRIPTION	DATE	ECO	APPR
A	RELEASE TO MFG.	07-Jun-17	4003	BMG

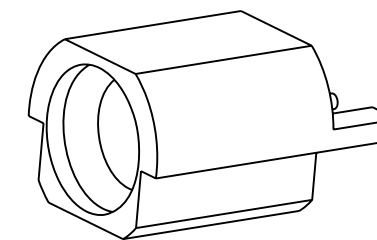
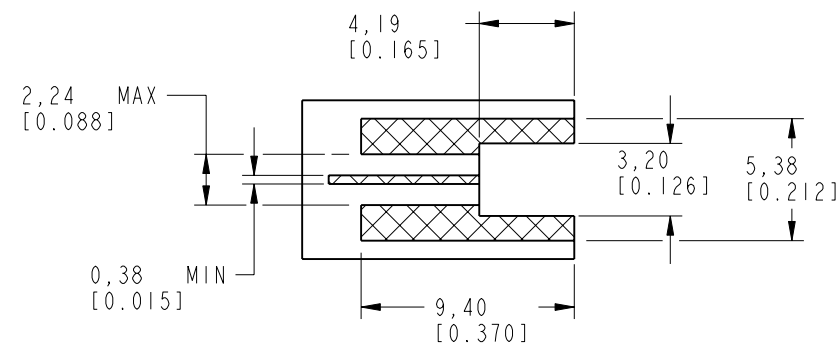

SCALE 7.000

RECOMMENDED PCB LAYOUT

SOLDER FOOTPRINT ONLY,
 PERFORMANCE WILL VARY
 BASED ON BOARD LAYOUT

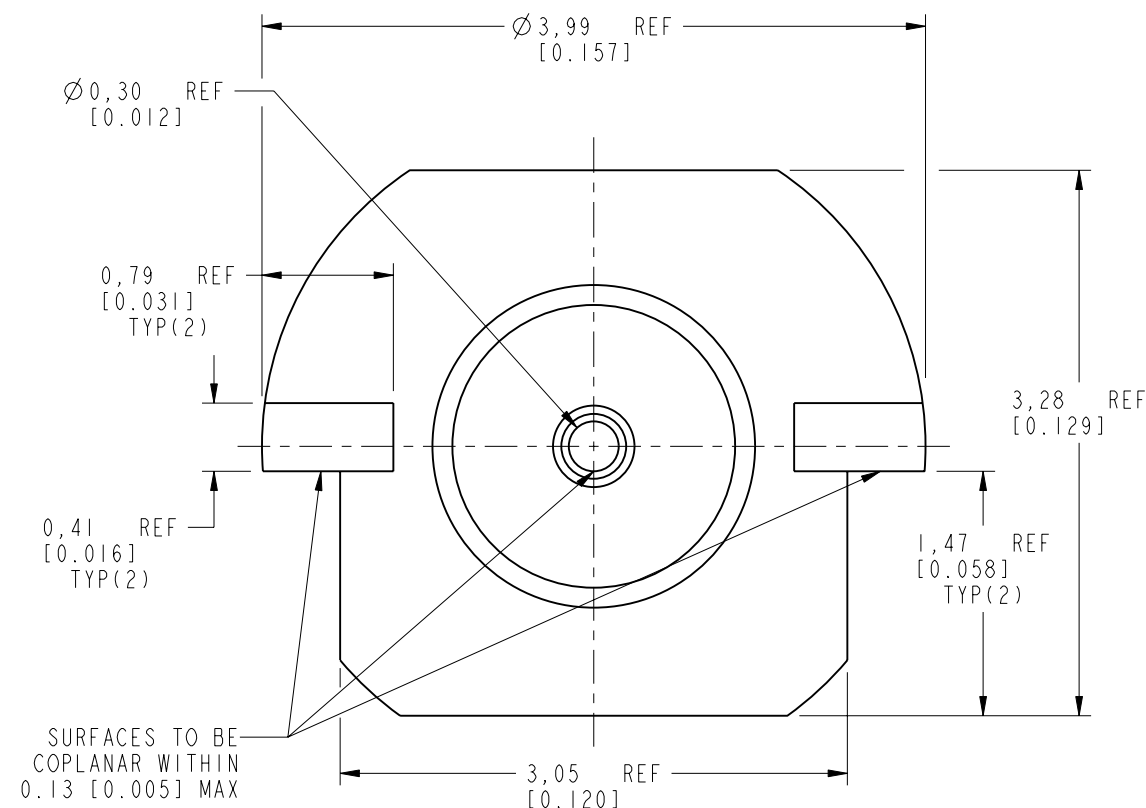
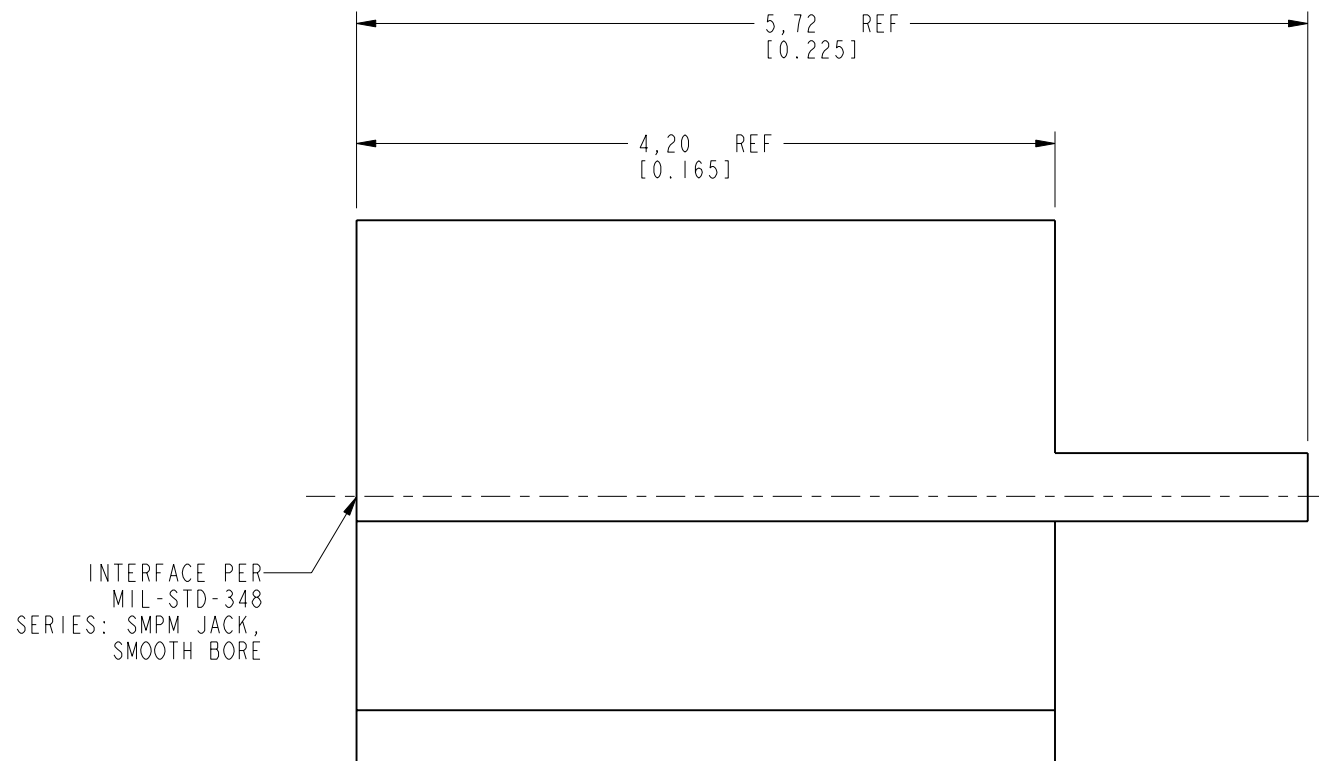

CUSTOMER OUTLINE DRAWING

ALL OTHER SHEETS ARE FOR INTERNAL USE ONLY

UNLESS OTHERWISE SPECIFIED, DIMENSIONS ARE IN METRIC AND TOLERANCES ARE: <0.5mm ±0.05mm 0.5 - 6mm ±0.1mm 6 - 30mm ±0.2mm 30 - 120mm ±0.3mm ANGLES ±1°	MATERIAL	DRAWN	DATE	TITLE SMPM STR JACK SMOOTH BORE, EDGE MOUNT	Amphenol RF www.amphenolrf.com
	SEE NOTES	S. DUAN	12-Jun-17		
NOTICE - These drawings, specifications, or other data (1) are, and remain the property of Amphenol corp. (2) must be returned upon request; and (3) are confidential and not to be disclosed to any person other than those to whom they are given by Amphenol Corp. the furnishing of these drawings, specifications, or other data by Amphenol Corp., or to any other person to anyone for any purpose is not to be regarded by implication or otherwise in any manner licensing, granting rights to permitting such holder or any other person to manufacture, use or sell any product, process or design, patented or otherwise, that may in any way be related to or disclosed by said drawings, specifications, or other data.	REFERENCE	ENGINEER	DATE	SCALE: 22.0:1.0	DRAWING NO. 925-169J-5IPT ITEM NO. 925-169J-5IPT PART NO. 925-169J-5IPT
	7607	B. GREENBAUM	12-Jun-17	SHEET 2 OF 3	
	CONFIGURATION LEVEL: In Work	APPROVED	DATE		DWG SIZE
FINISH	S. HSIEH	23-Jun-17		B	A

THIRD ANGLE PROJ.

REVISIONS

REV	DESCRIPTION	DATE	ECO	APPR
A	RELEASE TO MFG.	07-Jun-17	4003	BMG

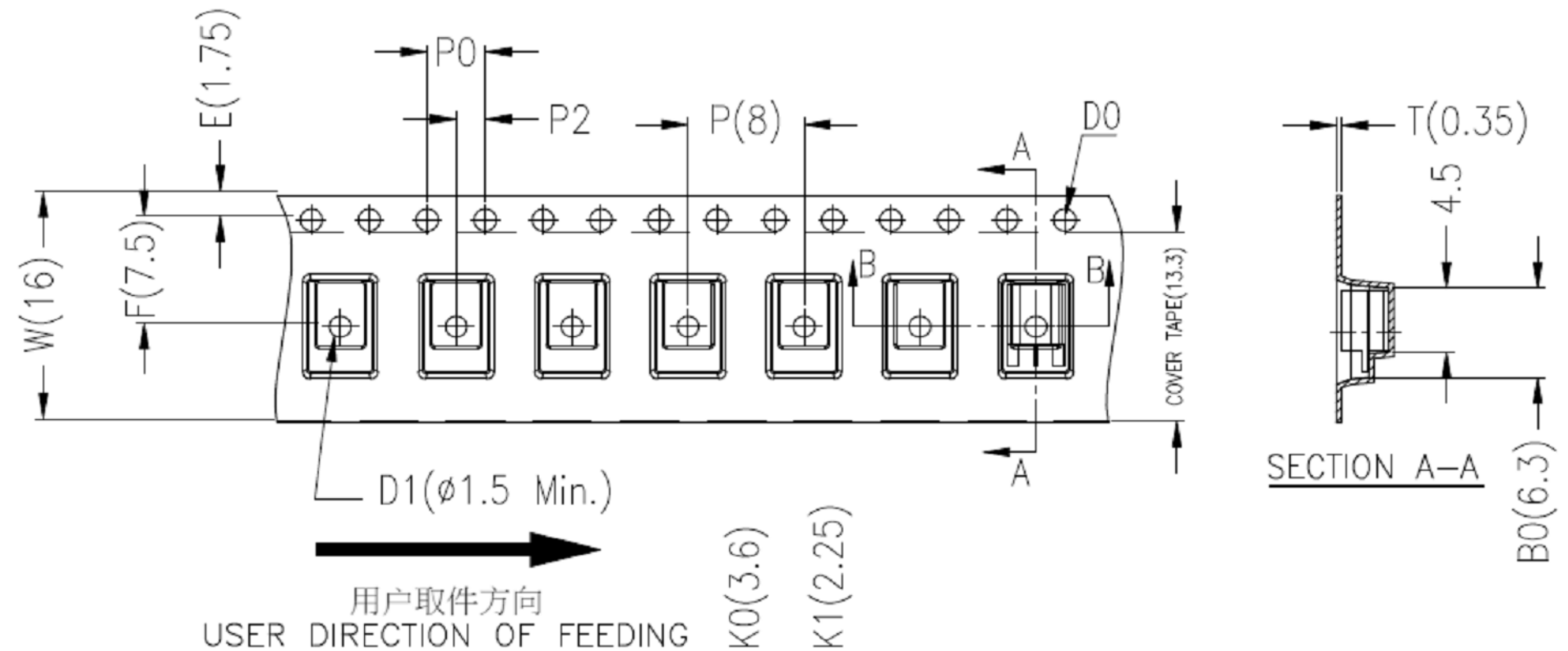
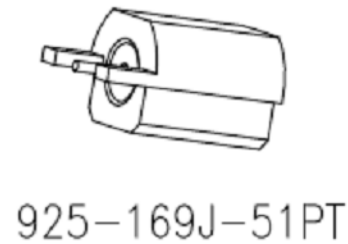

NOTES:

- 10 sprocket holes pitch cumulative tolerance ± 0.20 mm.
- Carrier camber not to exceed 1 mm in 250 mm.
- A0 and B0 measured on a plane 0.3 mm above the bottom of the pocket.
- K0 measured from a plane on the inside bottom of the pocket to the top surface of the carrier.
- All dimensions meet EIA-481-D requirements.
- Material of carrier tape: Black PS (RoHS Compliant)
- Thickness: 0.35 ± 0.05 mm.
- Packing length per 13" reel: 18.2 Meters.
- Component loader per 13" reel: 2200 pcs.

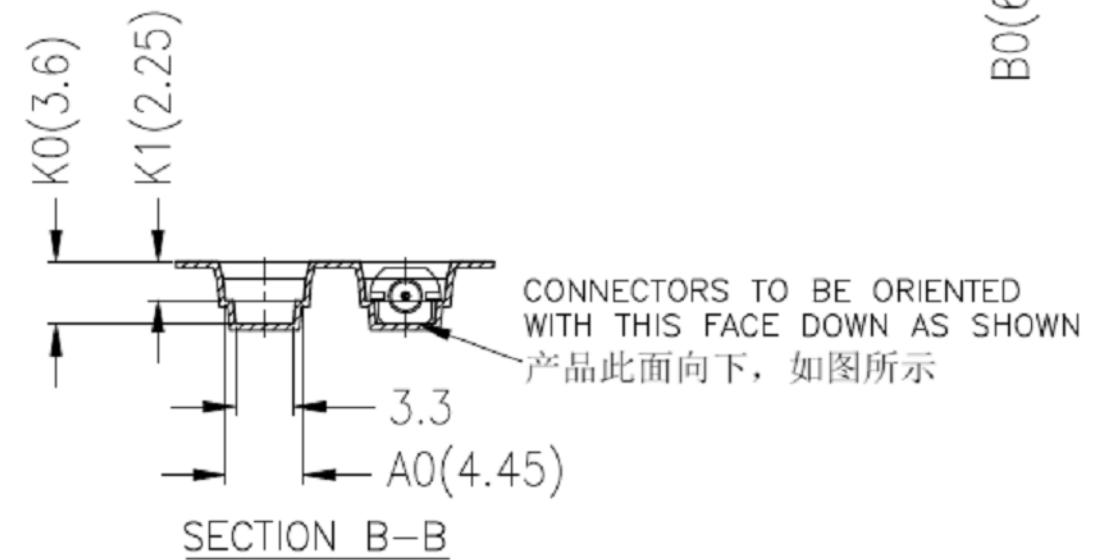

注:未注公差为 ± 0.10

NOTE: ALL TOLERANCES ARE: ± 0.10 , EXCEPT WHERE NOTED

ITEM	W	A ₀	B ₀	K ₀	K ₁	P	F	E	D ₀	D ₁	P ₀	P ₂	T
DIM	16 ± 0.3	4.45 ± 0.1	6.3 ± 0.1	3.6 ± 0.1	2.25 ± 0.1	8.0 ± 0.1	7.5 ± 0.1	1.75 ± 0.1	1.5 $^{+0.1}_{-0.00}$	1.5Min.	4.0 ± 0.1	2.0 ± 0.1	0.35 ± 0.05

UNLESS OTHERWISE SPECIFIED, DIMENSIONS ARE IN METRIC AND TOLERANCES ARE:
 < 0.5mm ± 0.05 mm 0.5 - 6mm ± 0.1 mm 6 - 30mm ± 0.2 mm 30 - 120mm ± 0.3 mm ANGLES $\pm 1^\circ$

NOTICE - These drawings, specifications, or other data (1) are, and remain the property of Amphenol corp. (2) must be returned upon request; and (3) are confidential and not to be disclosed to any person other than those to whom they are given by Amphenol Corp. the furnishing of these drawings, specifications, or other data by Amphenol Corp., or to any other person to anyone for any purpose is not to be regarded by implication or otherwise in any manner licensing, granting rights to permitting such holder or any other person to manufacture, use or sell any product, process or design, patented or otherwise, that may in any way be related to or disclosed by said drawings, specifications, or other data.

MATERIAL	DRAWN S. DUAN	DATE 12-Jun-17
REFERENCE 7607	ENGINEER B. GREENBAUM	DATE 12-Jun-17
CONFIGURATION LEVEL: In Work	APPROVED S. HSIEH	DATE 23-Jun-17
FINISH	CAD FILE	

TITLE SMPM STR JACK SMOOTH BORE, EDGE MOUNT
SCALE: 25.0:1.0 SHEET 3 OF 3
DWG SIZE B
REV A

Amphenol RF www.amphenolrf.com	
DRAWING NO.	925-169J-51PT
ITEM NO.	925-169J-51PT
PART NO.	925-169J-51PT