

NOTES:

1. MATERIAL AND FINISH (PLATING THICKNESS IN MICRO-INCHES):

BODY BERYLLIUM COPPER, ALBALOY PLATING OVER SLIVER  
 CONTACT PIN BERYLLIUM COPPER, GOLD PLATING  
 INSULATOR PTFE, NATURAL

2. ELECTRICAL:

A. IMPEDANCE: 50 OHM  
 B. FREQUENCY RANGE: DC-10 GHz  
 C. RETURN LOSS: 30 dB MIN.@ DC-2 GHz  
 27 dB MIN.@ 2-4 GHz  
 24 dB MIN.@ 4-6 GHz  
 D. INSERTION LOSS:  $0.05X\sqrt{f(\text{GHz})}$  dB MAX.

E. INSULATION RESISTANCE: 5 GOHM MIN.  
 F. CENTER CONTACT RESISTANCE: 3 mOHM MAX.  
 OUTER CONTACT RESISTANCE: 2 mOHM MAX.  
 G. POWER HANDLING: 200 W MAX.@ 2.2 GHz AT 20°C  
 H. INTERMODULATION(3rd order): 160 dBc Min. 2X43dBm

3. MECHANICAL:

A. DURABILITY:  
 IF MATING PART IS SMOOTH BORE, CATCHERS MITT: 1000 CYCLES MIN.  
 IF MATING PART IS LIMITED & FULL DETENT: 100 CYCLES MIN.  
 B. TEMPERATURE RANGE: -65°C TO +165°C

4. ALL MATERIALS MUST BE "RoHS" COMPLIANT

THIRD ANGLE PROJ.

REVISIONS

REV	DESCRIPTION	DATE	ECO	APPR
A	RELEASE TO MFG	26-Aug-15		AY
B	TITLE WAS CHANGED, ADDED PART NO. PSMP-FSBA-1175	29-Oct-15	50843	AY

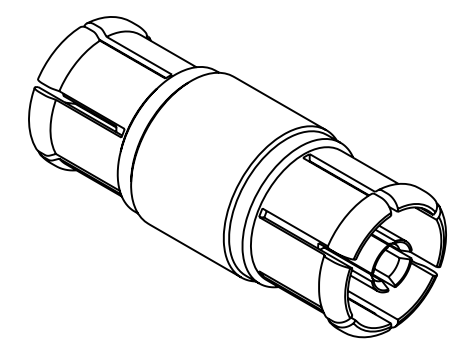

SCALE 5.000

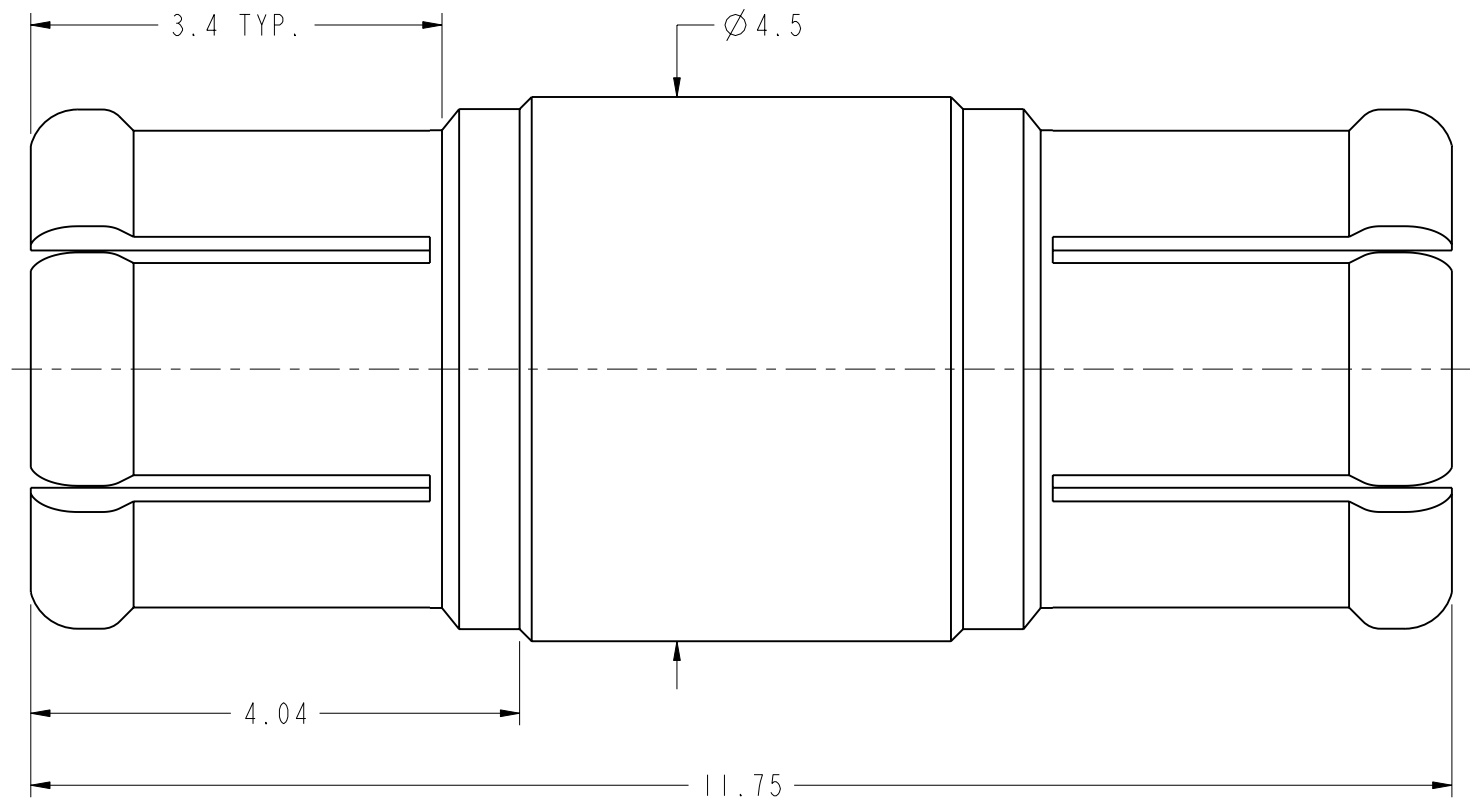

**CUSTOMER OUTLINE DRAWING**  
 ALL OTHER SHEETS ARE FOR INTERNAL USE ONLY

UNLESS OTHERWISE SPECIFIED, DIMENSIONS ARE IN METRIC AND TOLERANCES ARE: <0.5mm ±0.05mm    0.5 - 6mm ±0.1mm    6 - 30mm ±0.2mm    30 - 120mm ±0.3mm    ANGLES ±1° NOTICE - These drawings, specifications, or other data (1) are, and remain the property of Amphenol corp. (2) must be returned upon request; and (3) are confidential and not to be disclosed to any person other than those to whom they are given by Amphenol Corp. the finishing of these drawings, specifications, or other data by Amphenol Corp., or to any other person to anyone for any purpose is not to be regarded by implication or otherwise in any manner licensing, granting rights to permitting such holder or any other person to manufacture, use or sell any product, process or design, patented or otherwise, that may in any way be related to or disclosed by said drawings, specifications, or other data.	MATERIAL	DRAWN STAMN	DATE 20-Nov-15	TITLE PSMP BULLET 11.75 MM LONG	Amphenol RF Danbury CT USA, Tainan, Taiwan, Shenzhen, China www.amphenolrf.com	
	REFERENCE EAR 6570	ENGINEER RICKSON	DATE 27-Aug-15			DRAWING NO. PSMP7071A1-003-AT8GPA-50
	FINISH	APPROVED S. HSIEH	DATE 20-Nov-15	SCALE: 15.0:1.0   SHEET 2 OF 2		ITEM NO. 677071ABHA1BT5F
		I:\PSMP\PSMP7071A1-003-AT8GPA-50	CAD FILE	DWG SIZE B		REV B