

REVISIONS					
REV	ECO	DESCRIPTION	DATE	BY	APPR
A1	-	RELEASE NEW DRAWING	10APR18	ROOKIE	TOMMY
A2	-	REVISED DESCRIPTION	12JUN19	JAH	DH

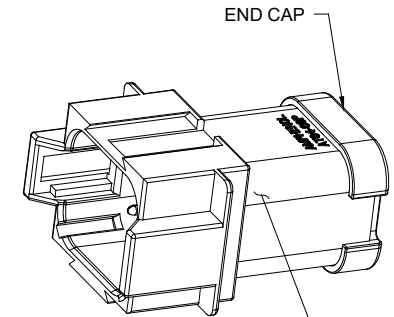

1 REFER TO SHEET 2 FOR AVAILABLE CONNECTOR COLORS

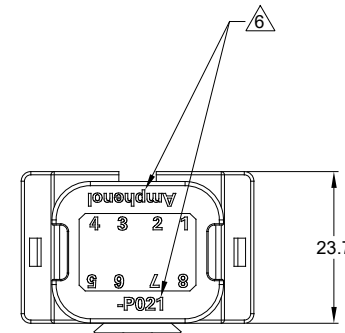
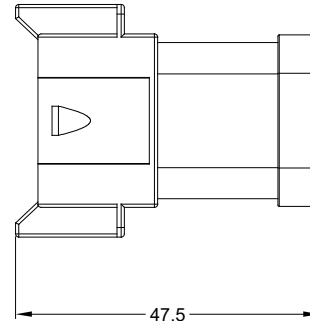
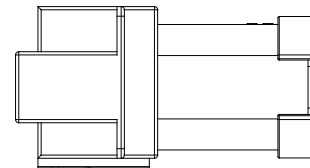
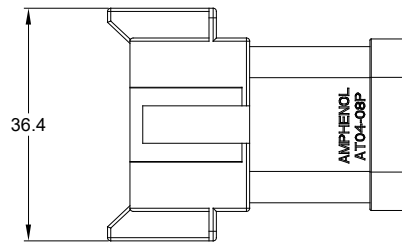
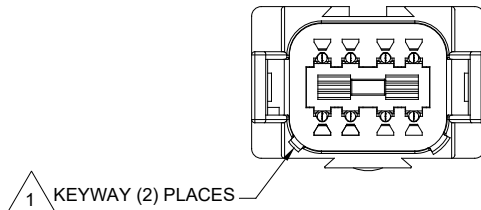

1 KEYWAY (2) PLACES

NOTES: UNLESS OTHERWISE SPECIFIED

△ SEE SHEET 2 FOR KEY ARRANGEMENTS AND COLORS.

2. MATERIAL:
HOUSING: THERMOPLASTIC
SEAL: SILICONE RUBBER
CONTACT: COPPER ALLOY

3. MODIFICATIONS: 8 PIN BUSBAR WITH NICKEL PLATED

4. SPECIFICATIONS:
4.1 CURRENT RATING: 52 AMPS MAXIMUM FOR THE 8 PIN BUSBAR
4.2 OPERATING TEMPERATURE: -55°C TO +125°C.
4.3 DIELECTRIC WITHSTANDING VOLTAGE: LESS THAN 2 MILLIAMPS CURRENT LEAKAGE @ 1500 VOLTS AC.
4.4 INSULATION RESISTANCE: 1000 MEGOHM MIN @ 25°C.
4.5 MOISTURE RESISTANCE: IP67 (MATED CONDITION).
4.6 MATING CYCLE DURABILITY: 100 CYCLES
4.7 RoHS COMPLIANT

5. MATING PART: AT06-08SX* PLUG
(X=A,B,C,D KEYS * = AVAILABLE MODIFICATIONS)

△ ORIENTATION OF "Amphenol" AND "-P021" TO BE OPTIONAL

7. ALL DIMENSIONS ARE FOR REFERENCE USE ONLY.

QUANTITY	SEE SHEET 2	REF: DT04-08PA-P021, DT04-08PB-P021	DESCRIPTION	ITEM
MATERIALS LIST				
UNLESS OTHERWISE SPECIFIED 1) All dimensions are in metric (mm). 2) Tolerances are as follows: 1 PL DEC ±0.30 2 PL DEC ±0.15 3 PL DEC ±0.08 3) Note reference = △		SIGNATURES DATE DRAWN: ROOKIE 10APR18 CHECKED: ORION 10APR18 ENGINEER: APPROVAL: TOMMY 10APR18 CUSTOMER:		 Sine Systems - www.amphenol-sine.com 44724 Morley Drive Clinton Township, MI 48036
MATERIAL SPECIFICATIONS:		THIS DRAWING IS SUPPLIED FOR INFORMATION ONLY. DESIGN FEATURES, SPECIFICATIONS AND PERFORMANCE DATA SHOWN HEREON ARE THE PROPERTY OF THE AMPHENOL CORPORATION. NO RIGHTS OF REPRODUCTION ARE IMPLIED. ALL DIMENSIONS ARE SUBJECT TO NORMAL MANUFACTURING VARIATIONS.		
PROCESS SPECIFICATIONS:		SIZE: B	TYPE: C-	DWG NO: AT04-08PX-P021
NEXT ASSY:		SCALE: NONE	REVISION: A2	SHEET 1 OF 2

TITLE: HYPERBUSS AT 8WAY REC/P 8 PIN BUSBAR NICKEL-PLATED

DWG NO:

AT04-08PX-P021

REV: A2

SH: 1

OF: 2

REVISIONS					
REV	ECO	DESCRIPTION	DATE	BY	APPR
A1	-	RELEASE NEW DRAWING	10APR18	ROOKIE	TOMMY
A2	-	REVISED DESCRIPTION	12JUN19	JAH	DH

P/N AT04-08PA-P021
KEY-A CONFIGURATION
STANDARD COLOR: GREY

P/N AT04-08PB-P021
KEY-B CONFIGURATION
STANDARD COLOR: BLACK

P/N AT04-08PC-P021
KEY-C CONFIGURATION
STANDARD COLOR: GREEN

P/N AT04-08PD-P021
KEY-D CONFIGURATION
STANDARD COLOR: BROWN

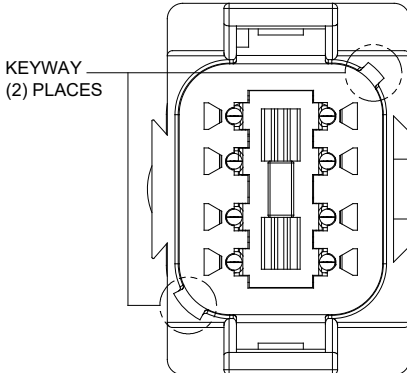
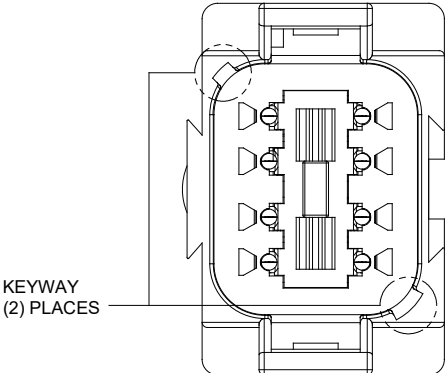
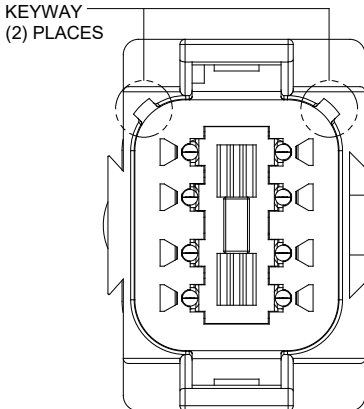
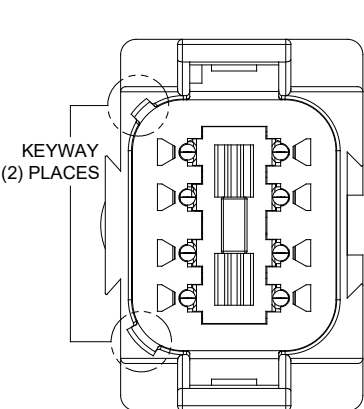

QUANTITY	PART NUMBER	DESCRIPTION	ITEM
MATERIALS LIST			
UNLESS OTHERWISE SPECIFIED 1) All dimensions are in metric (mm). 2) Tolerances are as follows: 1 PL DEC ±0.30 2 PL DEC ±0.15 3 PL DEC ±0.08 3) Note reference =		SIGNATURES DATE DRAWN: ROOKIE 10APR18 CHECKED: ORIGN 10APR18 ENGINEER: APPROVAL: TOMMY 10APR18	 Sine Systems - www.amphenol-sine.com 44724 Morley Drive Clinton Township, MI 48036
MATERIAL SPECIFICATIONS:		CUSTOMER:	HYPERBUSS AT 8WAY RECEPTACLE 8 PIN BUSBAR NICKEL-PLATED
PROCESS SPECIFICATIONS:		THIS DRAWING IS SUPPLIED FOR INFORMATION ONLY. DESIGN FEATURES, SPECIFICATIONS AND PERFORMANCE DATA SHOWN HEREON ARE THE PROPERTY OF THE AMPHENOL CORPORATION. NO RIGHTS OF REPRODUCTION ARE IMPLIED. ALL DIMENSIONS ARE SUBJECT TO NORMAL MANUFACTURING VARIATIONS.	
NEXT ASSY:			
		SIZE: B C- SCALE: NONE	DWG NO: AT04-08PX-P021 REVISION: A2
			SHEET 2 OF 2

TITLE: HYPERBUSS AT 8WAY RECP 8 PIN BUSBAR NICKEL-PLATED
 DWG NO: AT04-08PX-P021
 REV: A2
 SH: 2
 OF: 2