

REVISIONS				
REV	ECO	DESCRIPTION	DATE	BY APPR
A1	-	RELEASED DRAWING	Jul-16-18	Flan Tommy

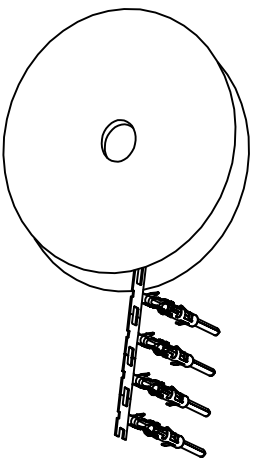

CONTACT ORIENTATION ON ROLL(3000PCS/COIL)

NOTES : (UNLESS OTHERWISE SPECIFIED)

- MATERIAL :
  - CONTACT BODY : COPPER ALLOY.
  - OUTER SPRING : STAINLESS STEEL.
- SPECIFICATIONS :
  - CURRENT RATING : 13A MAX.
  - TERMINATION TYPE : CRIMPING.
  - WIRE RANGE : 22~20AWG.
  - WIRE INSULATION DIA(MAX) :  $\phi$ 2.5mm.
- RoHS COMPLIANT.
- ALL DIMENSIONS ARE FOR REFERENCE USE ONLY.
- AVAILABLE TOOLS :
  - HAND CRIMPER : MFX-3954.
  - CRIMP APPLICATOR : MFX-3957.
  - EXTRACTION TOOL : QXRT16.

P/N	CONTACT PLATING(MATING AREA)
SP20M2T	TIN PLATING OVER NICKEL.
SP20M2N	NICKEL PLATING OVER COPPERIZE.
SP20M2F	GOLD FLASH PLATING OVER NICKEL.
SP20M2G5	5 $\mu$ "GOLD PLATING OVER NICKEL.
SP20M2G10	10 $\mu$ "GOLD PLATING OVER NICKEL.
SP20M2G15	15 $\mu$ "GOLD PLATING OVER NICKEL.
SP20M2G30	30 $\mu$ "GOLD PLATING OVER NICKEL.

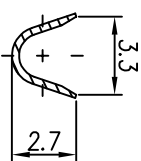
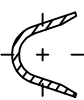
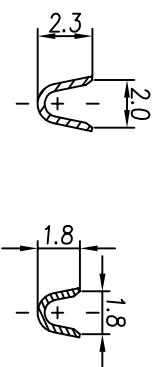
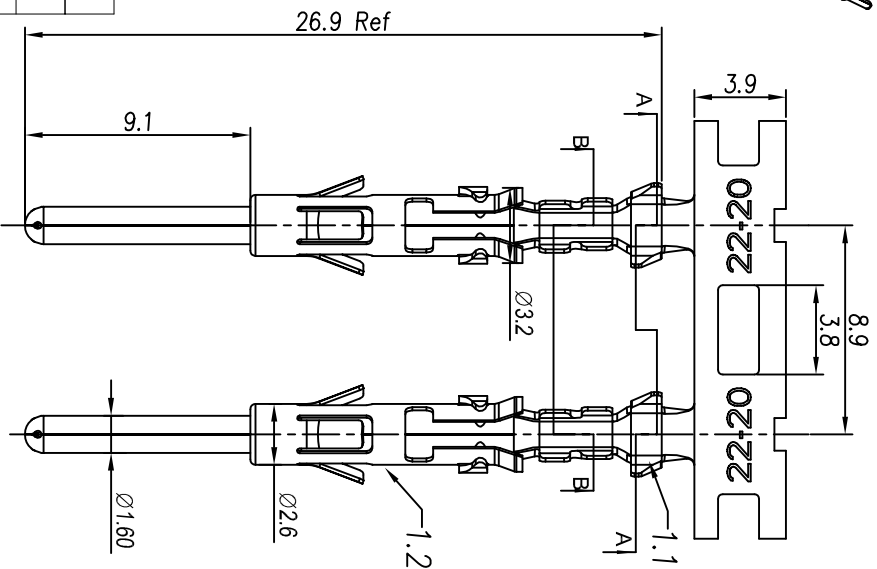

SECTION A-A

SECTION B-B

QUANTITY	PART NUMBER	DESCRIPTION	ITEM
<b>MATERIALS LIST</b>			
UNLESS OTHERWISE SPECIFIED 1) All dimensions are in millimeters. 2) Tolerances are as follows: 1 PL DEC 20.30 Fractions 1/16" 3 PL DEC 20.08 Fractions 1/16" 3) Note reference = $\Delta$			
PROCESS SPECIFICATIONS: MATERIAL SPECIFICATIONS: TEST SPECIMENS SURFACE FINISH: SPECIFICATIONS AND PERFORMANCE DATA: THE MANUFACTURING CORPORATION NO RIGHTS OF REPRODUCTION ARE GRANTED. ALL MANUFACTURING VARIATIONS.		CUSTOMER: Tommy APPROVAL: Jul-16-18 DATE: Jul-16-18 CHECKED: Jod ENGINEER: Jod DRAWN: Flan DATE: Jul-16-18 SIGNATURES:	
ECO-MATE PIN CONTACT. STAMPED.22-20AWG.SIZE 16		<b>Amphenol</b> Sine Systems - www.amphenol-sine.com 44724 Morley Drive Clinton Township, MI 48036	
SCALE: NONE	SIZE: B	TYPE: C-	REVISION: A1
SHEET: 1	OF: 1		