

PART NAME: NEMA 4X ENCLOSURE

PART No.:

PN-1342, PN-1342-C AND PN-1342-DG

INDUSTRY STANDARDS:
 POLYCARBONATE (LIGHT GRAY AND CLEAR)
 UL94V-2 FLAMMABILITY RATING (UL FILE #E41613)
 UV STABILIZED
 SERVICE TEMPERATURE RANGE: -40°C TD +120°C
 ABS (DARK GRAY)
 UL94-HB FLAMMABILITY RATING (UL FILE #E56070)
 SERVICE TEMPERATURE RANGE: -40°C TD +80°C

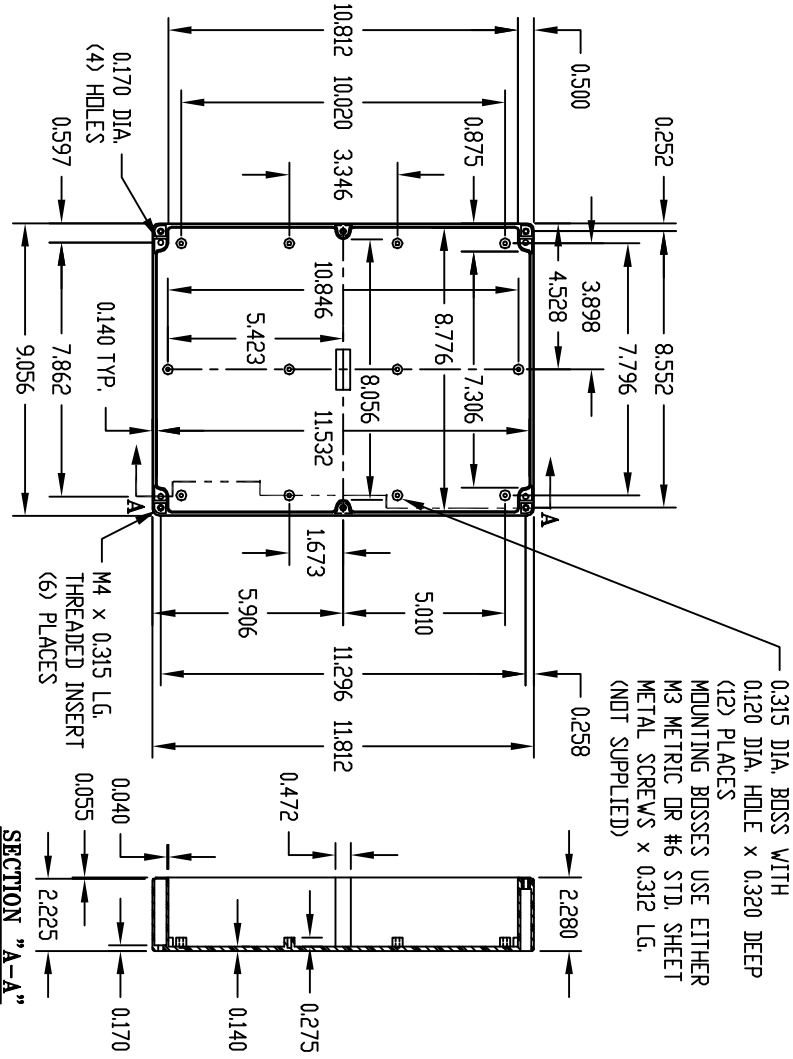

0.315 DIA. BOSS WITH
 0.120 DIA. HOLE x 0.320 DEEP
 (12) PLACES
 MOUNTING BOSSES USE EITHER
 M3 METRIC OR #6 STD. SHEET
 METAL SCREWS x 0.312 LG.
 (NOT SUPPLIED)



BODY

SECTION "A-A"



COVER

SECTION "B-B"

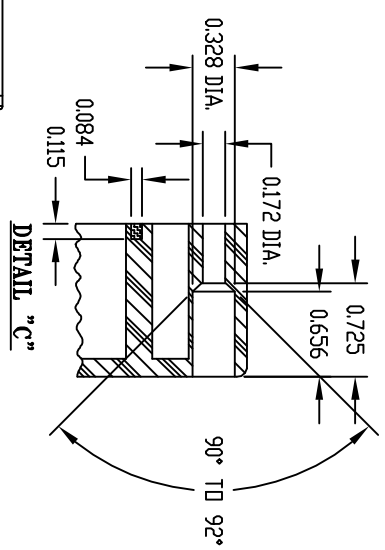

DETAIL "C"

SEE DETAIL "C"

NOTE: ALL DIMENSIONS HAVE ±0.015 TOLERANCE UNLESS OTHERWISE SPECIFIED.

PART NUMBER	MATERIAL		FINISH		HARDWARE KIT
	BODY	COVER	BODY	COVER	
PN-1342	POLYCARBONATE	POLYCARBONATE	LIGHT GRAY	CLEAR	KIT CONTAINS (6) M4 x 25mm (1.000") LG. SCREWS FOR ASSEMBLY
PN-1342-C	POLYCARBONATE	POLYCARBONATE	LIGHT GRAY	CLEAR	
PN-1342-DG	HIGH-IMPACT ABS	HIGH-IMPACT ABS	DARK GRAY	CLEAR	