

PART NAME: NEMA 4X ENCLOSURE

PART No.:

PN-1343, PN-1343-C AND PN-1343-DG

INDUSTRY STANDARDS:
 POLYCARBONATE (LIGHT GRAY AND CLEAR)
 UL94V-2 FLAMMABILITY RATING (UL FILE #E41613)
 UV STABILIZED
 SERVICE TEMPERATURE RANGE: -40°C TD +120°C
 ABS (DARK GRAY)
 UL94-HB FLAMMABILITY RATING (UL FILE #E56070)
 SERVICE TEMPERATURE RANGE: -40°C TD +80°C

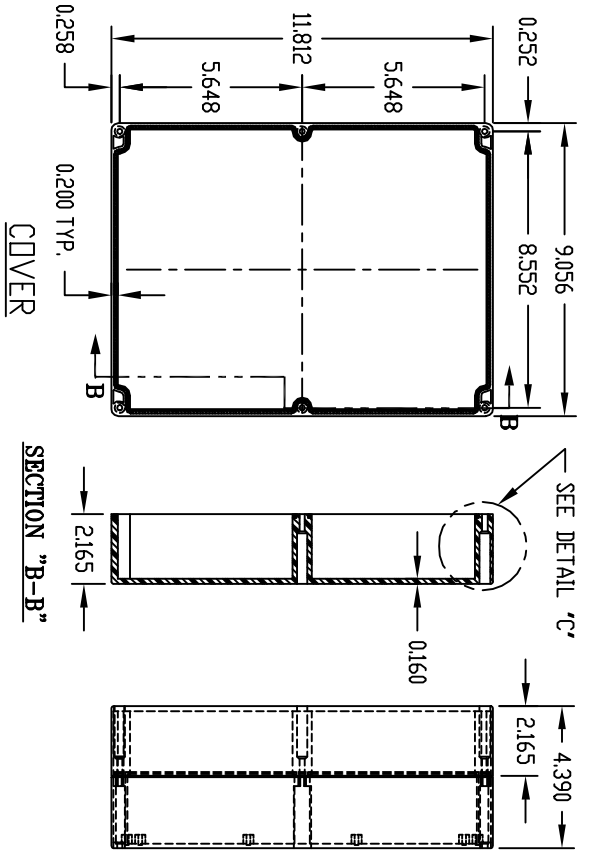
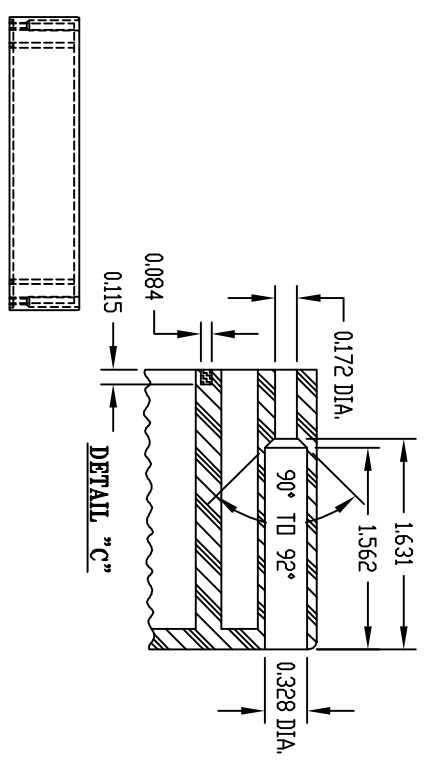
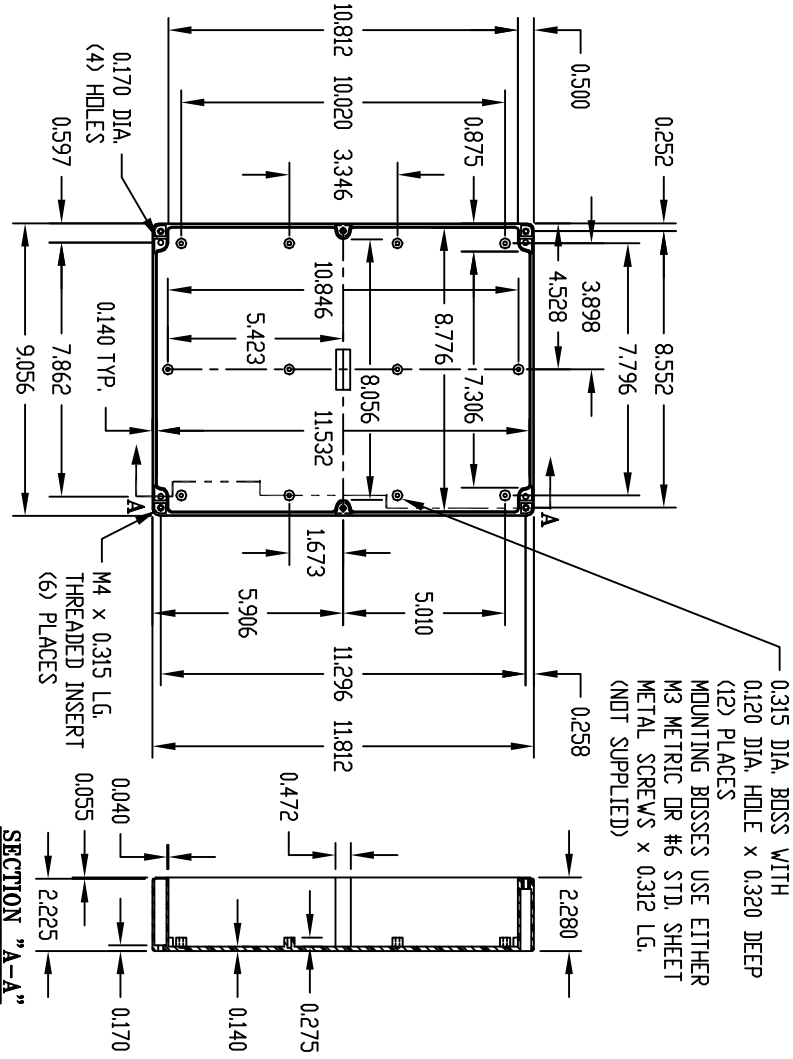

NOTE: ALL DIMENSIONS HAVE ±0.015 TOLERANCE UNLESS OTHERWISE SPECIFIED.

PART NUMBER	MATERIAL		FINISH		HARDWARE KIT
	BODY	COVER	BODY	COVER	
PN-1343	POLYCARBONATE	POLYCARBONATE	LIGHT GRAY	LIGHT GRAY	KIT CONTAINS (6) M4 x 25mm (1.000") LG. SCREWS FOR ASSEMBLY
PN-1343-C	POLYCARBONATE	POLYCARBONATE	LIGHT GRAY	CLEAR	
PN-1343-DG	HIGH-IMPACT ABS	HIGH-IMPACT ABS	DARK GRAY	DARK GRAY	