

THE INFORMATION CONTAINED IN THIS DRAWING IS THE SOLE PROPERTY OF BUD INDUSTRIES INC. ANY REPRODUCTION IN PART OR WHOLE WITHOUT THE WRITTEN PERMISSION OF BUD INDUSTRIES INC. IS PROHIBITED.

ISSUE	SEE TABLE
REVISIONS	

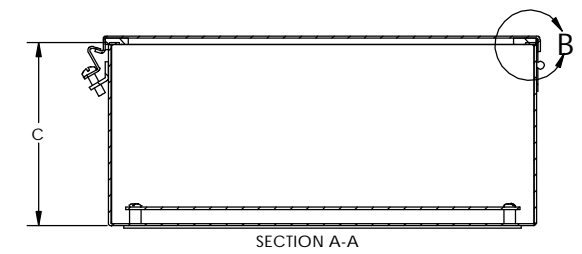
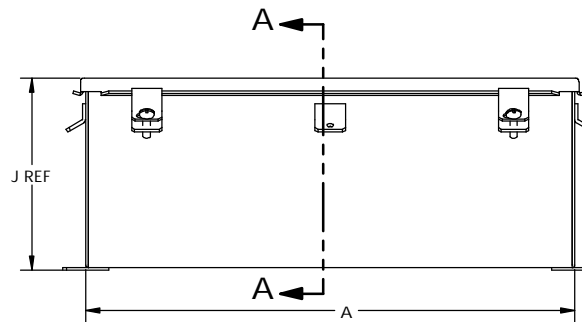
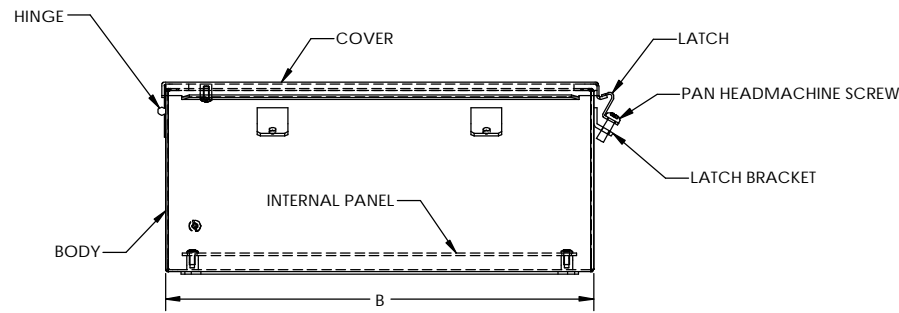
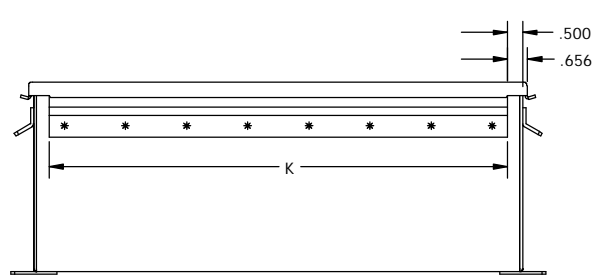
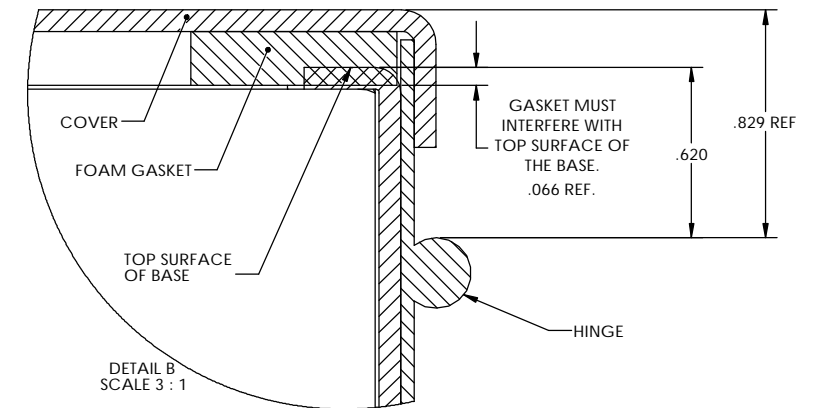
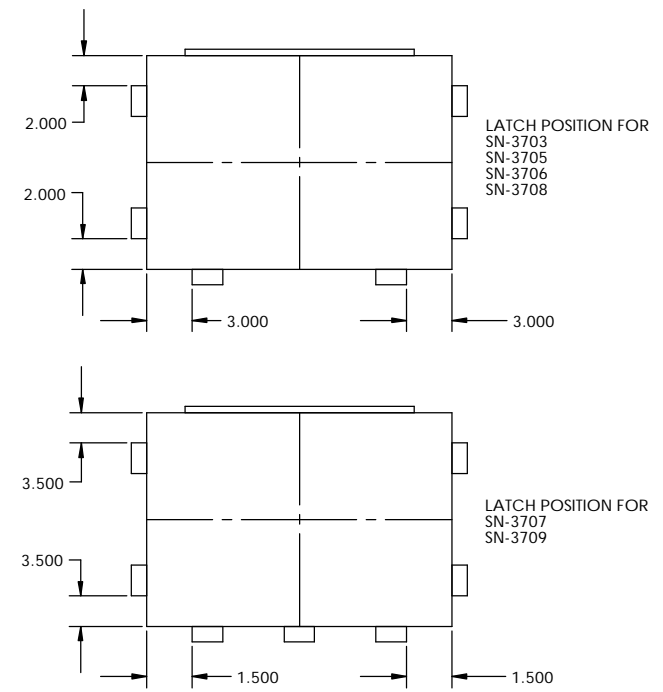
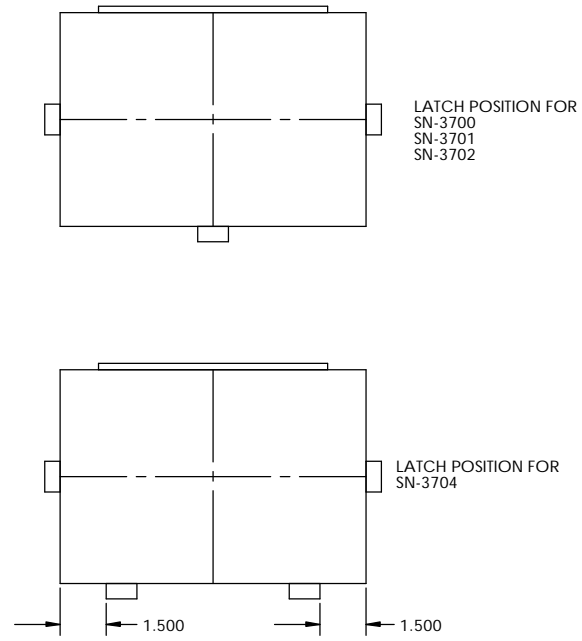
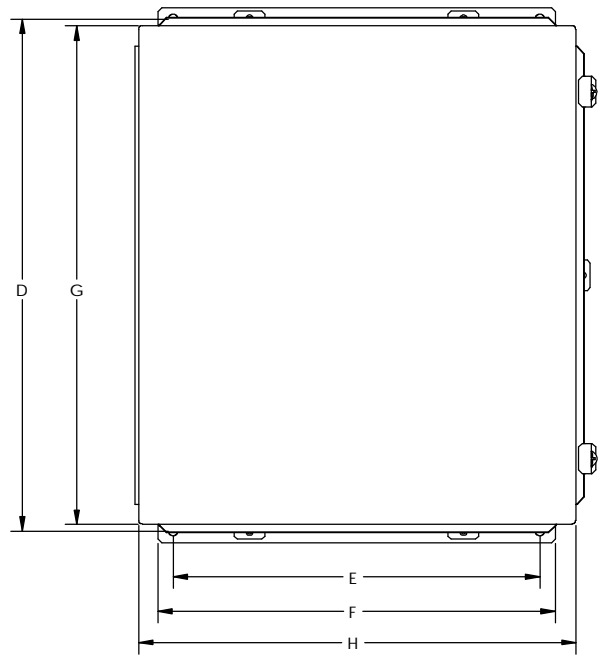
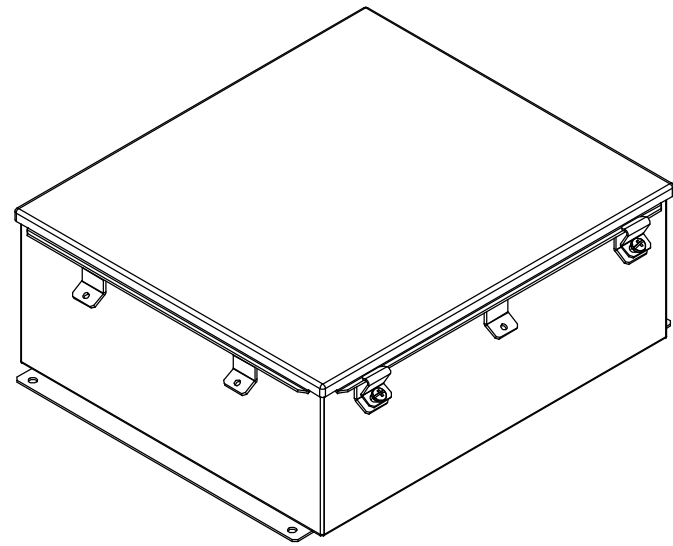

PART NUMBER	A	B	C	D	E	F	G	H	J	K	# BRACKETS/SCREWS/LATCHES
SN-3700	6.00	4.00	3.00	6.75	2.00	3.00	6.31	4.31	3.25	5.00	3
SN-3701	8.00	6.00	3.50	8.75	4.00	5.00	8.31	6.31	3.75	7.00	3
SN-3702	6.00	6.00	4.00	6.75	4.00	5.00	6.31	6.31	4.25	5.00	3
SN-3703	12.00	10.00	5.00	12.75	8.00	9.00	12.31	10.31	5.25	11.00	6
SN-3704	10.00	8.00	6.00	10.75	6.00	7.00	10.31	8.31	6.25	9.00	4
SN-3705	12.00	12.00	6.00	12.75	10.00	11.00	12.31	12.31	6.25	11.00	6
SN-3706	14.00	12.00	6.00	14.75	10.00	11.00	14.31	12.31	6.25	13.00	6
SN-3707	16.00	14.00	6.00	16.75	12.00	13.00	16.31	14.31	6.25	15.00	7
SN-3708	14.00	12.00	8.00	14.75	10.00	11.00	14.31	12.31	8.25	13.00	6
SN-3709	16.00	14.00	10.00	16.75	12.00	13.00	16.31	14.31	10.25	15.00	7

PARTS LIST		BUD INDUSTRIES INC.	
APPROVALS	DATE	DESIGN	DATE
DP	1/13/06		
MATERIAL AS NOTED		NEMA HINGED ENCLOSURE	
FINISH	SEE SPEC.	SCALE	SEE TABLE
QTY:	USED ON:	SCALE:	SHEET 1 OF 1