

9615 SW Allen, Suite 103  
 Beaverton, OR 97005  
 Phone: (503) 643-4899  
 800-275-4899  
 Fax: (503) 372-1266  
 Website: www.cui.com

# Specifications

1	Part No.	GA0506			
2	Nominal Size	50 mm.	2"	inch	
3	Impedance	20 $\Omega$ $\pm$ 15%	at	800 Hz.	1 V.
4	Resonance	450 Hz. $\pm$ 90 Hz.		F0 Hz.	1 V.
5	S.P. Level	86 dB/w $\pm$ 3 dB	0.25 w.	50 cm.	average at
6	Response	fo Hz. $\sim$ 5K Hz.	MAX 10dB	800, 1K, 1.3K, 1.6K Hz.	
7	Crossover Freq.	Hz.	Hz.	dB/OCT	Net work
8	Input Power	Nominal Input	0.25 w.	Handling Capacity	0.5 w.
9	Operation	Must be normal at program source			0.25 w.
10	Buzz, Rattle, etc.	Must be normal at sine wave			2.2 v.
11	Flux Density	Gauss $\pm$ 10%			
12	Total Flux	Max well min			
13	Magnet	Size	13 x 10	mm	gr oz
14	Total Weight				gr oz
15	Load Test	After test meet item 9 and 10	White noise	0.25 W.	5 Hours
16	Distortion	% MAX		Hz	W.
17	Heat Test	After test meet item 9 and 10	70 $\pm$ 2 $\pm$ $^{\circ}$ C	20-50 %R.H.	5 Hours
18	Humidity Test	After test meet item 9 and 10	40 $\pm$ 2 $\pm$ $^{\circ}$ C	90-95 %R.H.	5 Hours

PART NO.	GA0506	UNITS:	mm
DRAWN BY:		PAGE NO:	1 of 2

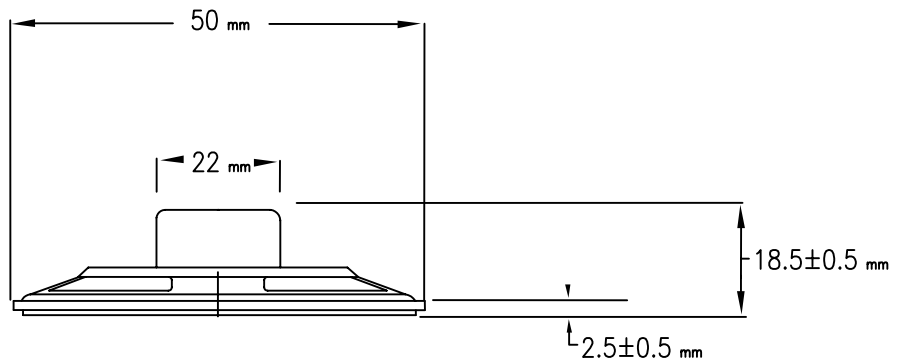
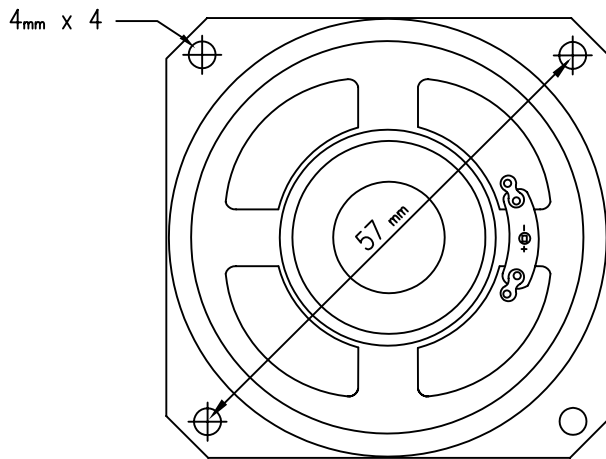

**CUI INC**

9615 SW Allen, Suite 103  
 Beaverton, OR 97005  
 Phone: (503) 643-4899  
 800-275-4899  
 Fax: (503) 372-1266  
 Website: www.cui.com

TITLE:

PART NO.

GA0506

UNITS:

mm

DRAWN BY:

Page No.

2 of 2