



9615 SW Allen, Suite 103
 Beaverton, OR 97005
 Phone: (503) 643-4899
 800-275-4899
 Fax: (503) 372-1266
 Website: www.cui.com

Specifications

1	Part No.	GA0771M			
2	Nominal Size	77 mm.	3"	inch	
3	Impedance	8 Ω \pm 15%	at	800 Hz.	1 V.
4	Resonance	300 Hz. \pm 60 Hz.	FO Hz.	1 V.	
5	S.P. Level	90 dB/w \pm 3 dB	0.5 w.	50 cm.	average at
6	Response	fo Hz. \sim 22K Hz. MAX 10dB	1.5K, 2K, 2.5K, 3K Hz.		
7	Crossover Freq.	Hz.	Hz.	dB/OCT	Net work
8	Input Power	Nominal Input	1 w.	Handling Capacity	2 w.
9	Operation	Must be normal at program source			1 w.
10	Buzz, Rattle, etc.	Must be normal at sine wave			2.83 v.
11	Flux Density	Gauss \pm 10%			
12	Total Flux	Max well min			
13	Magnet	Size	13 x 10 mm	gr	oz
14	Total Weight	gr oz			
15	Load Test	After test meet item 9 and 10	White noise	1 W.	5 Hours
16	Distortion	% MAX		Hz	W.
17	Heat Test	After test meet item 9 and 10	70 \pm 2 \pm °C	20-50 %R.H.	5 Hours
18	Humidity Test	After test meet item 9 and 10	40 \pm 2 \pm °C	90-95 %R.H.	5 Hours

PART NO.	GA0771M	UNITS:	mm
DRAWN BY:		PAGE NO:	1 of 2

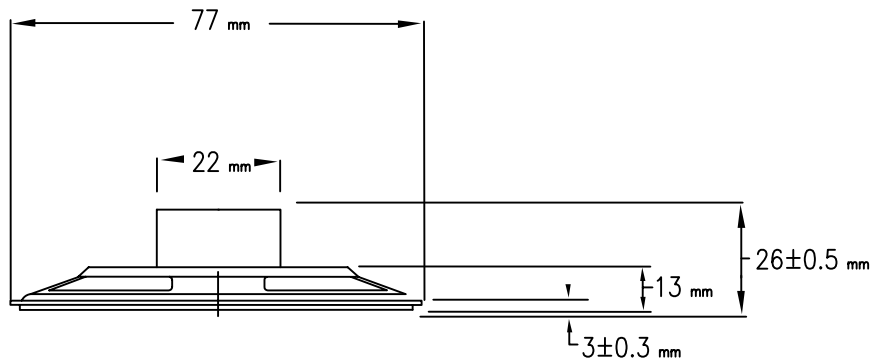
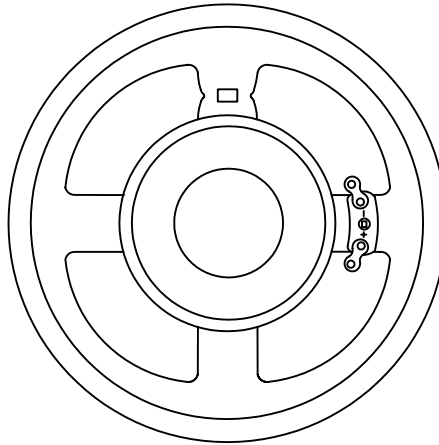

9615 SW Allen, Suite 103
Beaverton, OR 97005
Phone: (503) 643-4899
800-275-4899
Fax: (503) 372-1266
Website: www.cui.com

TITLE:

PART NO.

GA0771M

UNITS:

mm

DRAWN BY:

Page No.

2 of 2