

Tous droits strictement réservés. Reproduction ou communication à des tiers interdite sous quelque forme que ce soit sans autorisation écrite du propriétaire. Propriété de FCI. Droits de reproduction FCI.

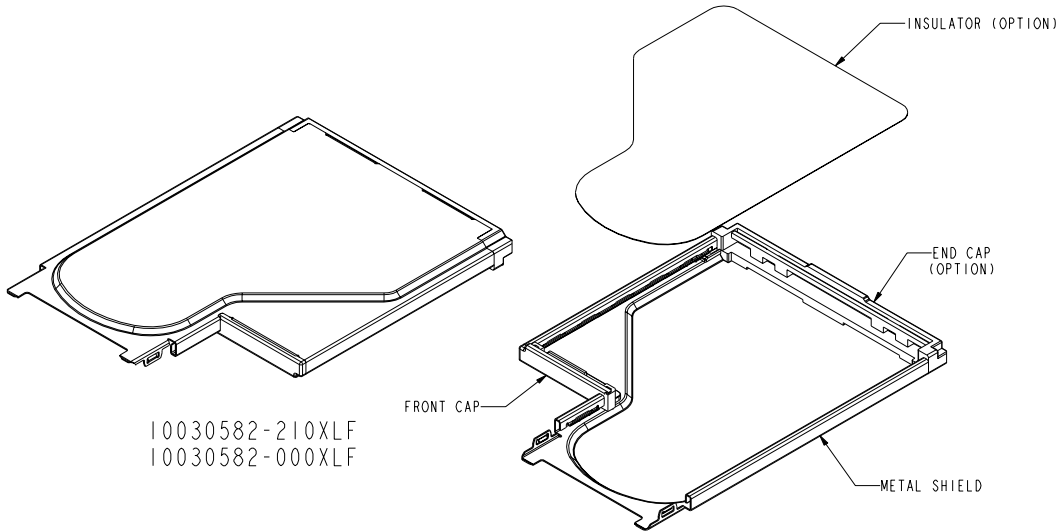

All rights strictly reserved. Reproduction or issue to third parties in any form whatever is not permitted without written authority from the proprietor. Property of FCI. Copyright FCI.

PRODUCT NO.	FRONT CAP	END CAP	INSULATOR	REMARK
10030582-2100LF	10030583-210	10030592-210	NO	
10030582-2101LF	10030583-210	10030592-210	YES	
10030582-0000LF	10030583-210	NO	NO	SEE NOTE 5
10030582-0001LF	10030583-210	NO	YES	SEE NOTE 5
10030582-0010LF	10030583-210	NO	NO	
10030582-0011LF	10030583-210	NO	YES	
10030582-0020LF	10030583-210	NO	NO	
10030582-0021LF	10030583-210	NO	YES	



NOTES:

- THIS PRODUCT CONTAINS ONE METAL SHIELD, PLASTIC FRONT CAP, INSULATOR AND ONE PLASTIC END CAP.
- PRODUCT PERFORMANCE PER SPEC. GS-12-292.
- PART NUMBER SCHEME:
10030582- X X X X L F

- INSULATOR: 0:NO, 1:YES
- 0 : STANDARD SHIELD
- 1 : EXTENDED SHIELD
- 2 : CUSTOMIZED
- PLASTIC COLOR
- 0 : W/O END CAP
- 1 : BLACK
- OFFSET (END CAP)
- 0 : W/O END CAP
- 1 : +0.00 (NOT TOOLED)
- 2 : +0.30
- 3 : +0.60 (NOT TOOLED)

- PACKAGING SPEC. PER GS-14-927.
- THE P/N IS TEMPORARY FOR CUSTOMER SPECIAL REQUEST; STANDARD SHIELD MATING WITH END CAP IS THE RECOMMENDED PARTS.

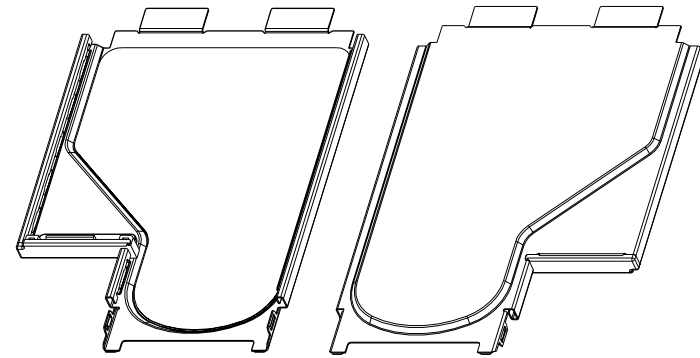

10030582-001XLF

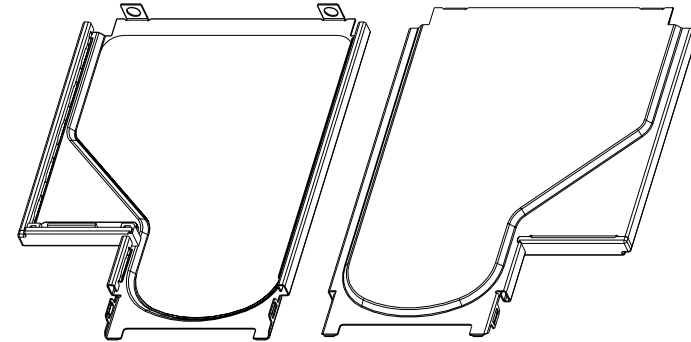

10030582-002XLF

tolerance unless otherwise specified	
linear	.X ± .30 .XX ± .15 .XXX ± .08
angles	X° ± 2°

www.fciconnect.com	<input checked="" type="checkbox"/> tolerance	projection	size A4	Scale 1.000
Chr PAUL WANG 10/04/04 Material	Appr JOSEPH HSIA 10/04/04	ECN		
title EXPRESSCARD/54 MODULE CARD KIT BOTTOM SHIELD SUB-ASSEMBLY		dwg no 10030582	Rev. E	
catalog no		CUSTOMER DRAWING	sheet 1 of 4	

rev	ecn no	dr	date
A	T04-0382	D T	11/04/04
B	T05-0083	D T	04/18/05
C	T05-0152	D T	07/11/05
D	T05-0228	D T	10/18/05
E	T06-0015	D T	01/16/06

Tous droits strictement réservés. Reproduction ou communication à des tiers interdite sans quelque forme que ce soit sans autorisation écrite du propriétaire. Propriété de FCI. Droits de reproduction FCI.



All rights strictly reserved. Reproduction or issue to third parties in any form whatever is not permitted without written authority from the proprietor. Property of FCI. Copyright FCI.

PRODUCT NO.
10030582-210XLF

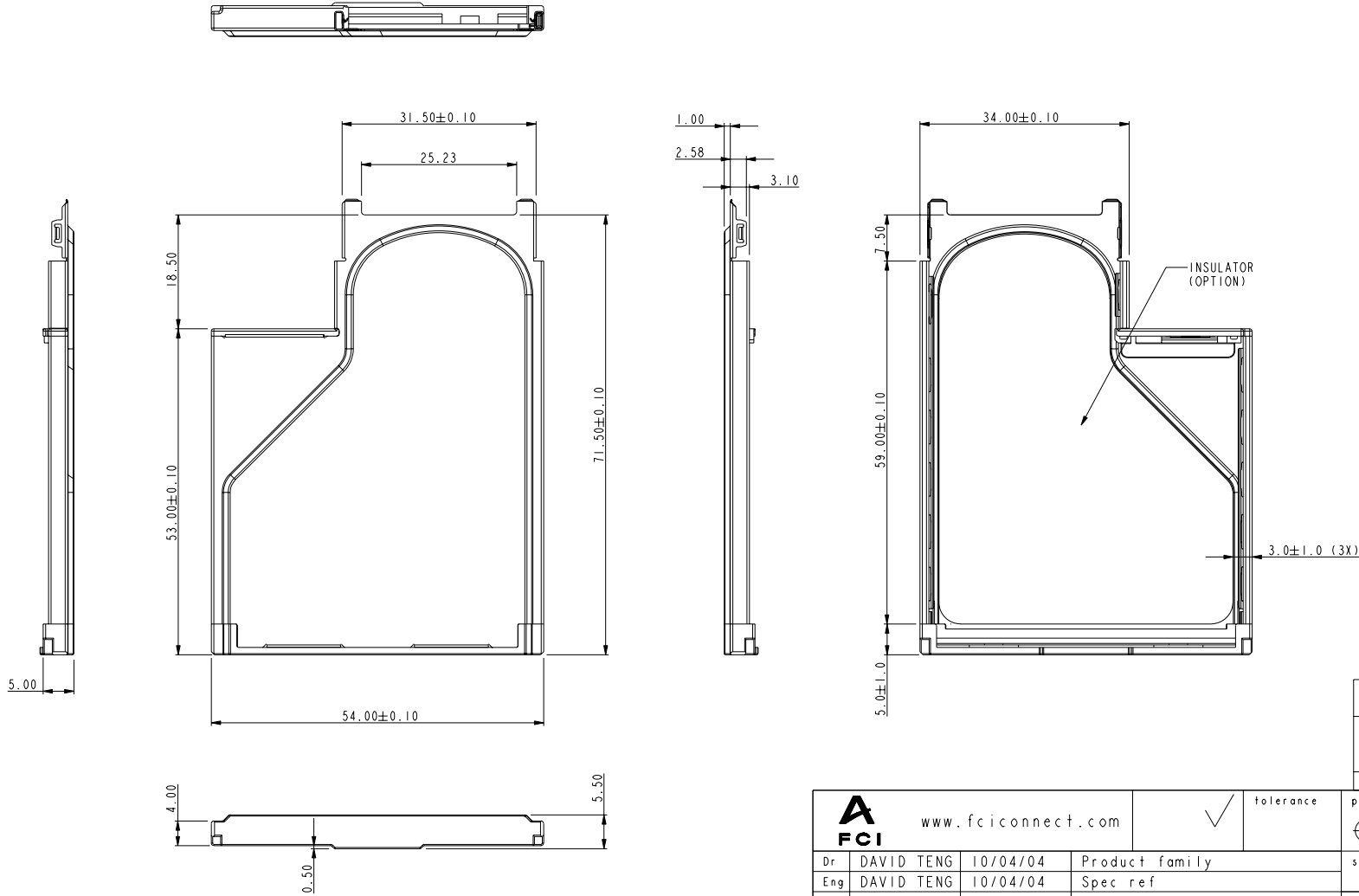

tolerance unless otherwise specified	
linear	.X ± .30
	.XX ± .15
	.XXX ± .08
angles	X° ± 2°

Dr	DAVID TENG	10/04/04	Product family	www.fciconnect.com	✓	tolerance	projection	MM		
								size	A4	Scale
Eng	DAVID TENG	10/04/04	Spec ref			ECN				
Chr	PAUL WANG	10/04/04	Material							
Appr	JOSEPH HSIA	10/04/04								
Title			EXPRESSCARD/54 MODULE CARD KIT		dwg no		10030582		Rev.	
			BOTTOM SHIELD SUB-ASSEMBLY						E	
catalog no					CUSTOMER DRAWING		sheet 2 of 4			

Tous droits strictement réservés. Reproduction ou communication à des tiers interdite sous quelque forme que ce soit sans autorisation écrite du propriétaire. Propriété de FCI. Droits de reproduction FCI.



All rights strictly reserved. Reproduction or issue to third parties in any form whatever is not permitted without written authority from the proprietor. Property of FCI. Copyright FCI.

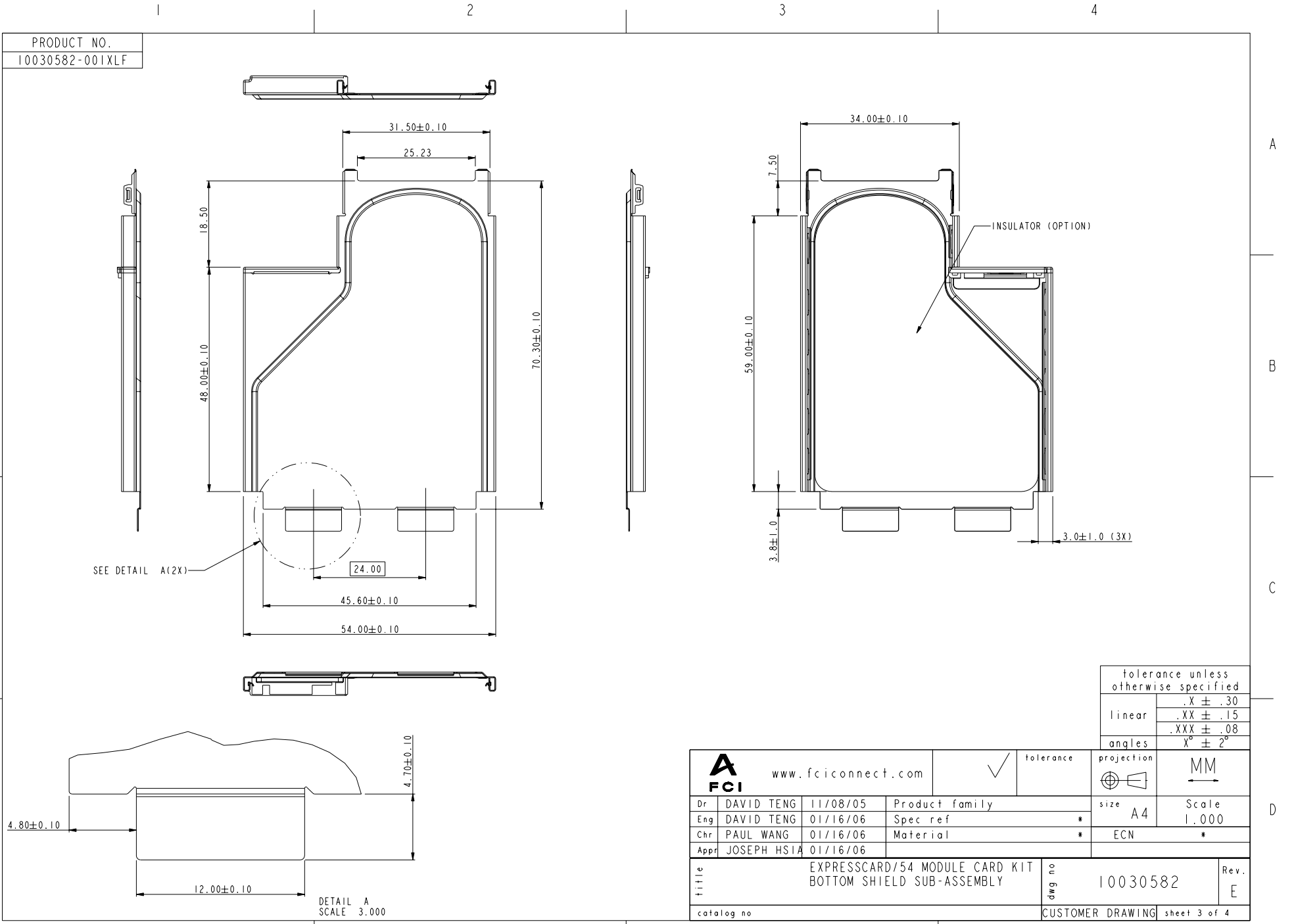

tolerance unless otherwise specified	
linear	.X ± .30 .XX ± .15 .XXX ± .08
angles	X° ± 2°

www.fciconnect.com	<input checked="" type="checkbox"/> tolerance	projection	MM
Dr DAVID TENG 11/08/05	Product family		
Eng DAVID TENG 01/16/06	Spec ref *		
Chr PAUL WANG 01/16/06	Material *	ECN *	
Appr JOSEPH HSIA 01/16/06			
Title EXPRESSCARD/54 MODULE CARD KIT BOTTOM SHIELD SUB-ASSEMBLY		dwg no 10030582	Rev. E
catalog no		CUSTOMER DRAWING	sheet 3 of 4

Tous droits strictement réservés. Reproduction ou communication à des tiers interdite sous quelque forme que ce soit sans autorisation écrite du propriétaire. Propriété de c FCI. Droits de reproduction FCI.



All rights strictly reserved. Reproduction or issue to third parties in any form whatever is not permitted without written authority from the proprietor Property of FCI. Copyright FCI.

PRODUCT NO.
10030582-002XLF

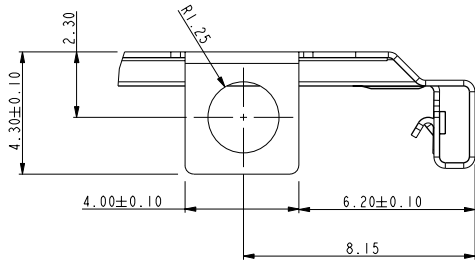
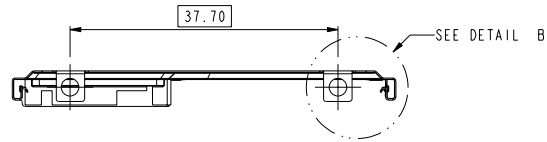
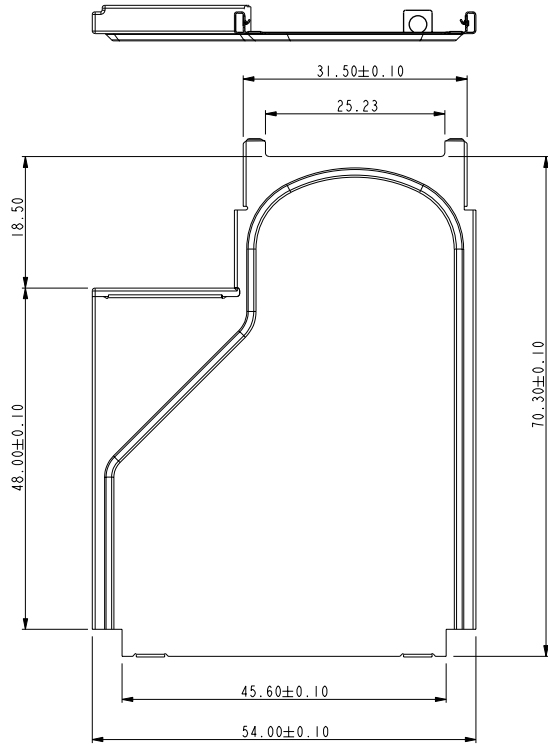

DETAIL B
SCALE 4.000

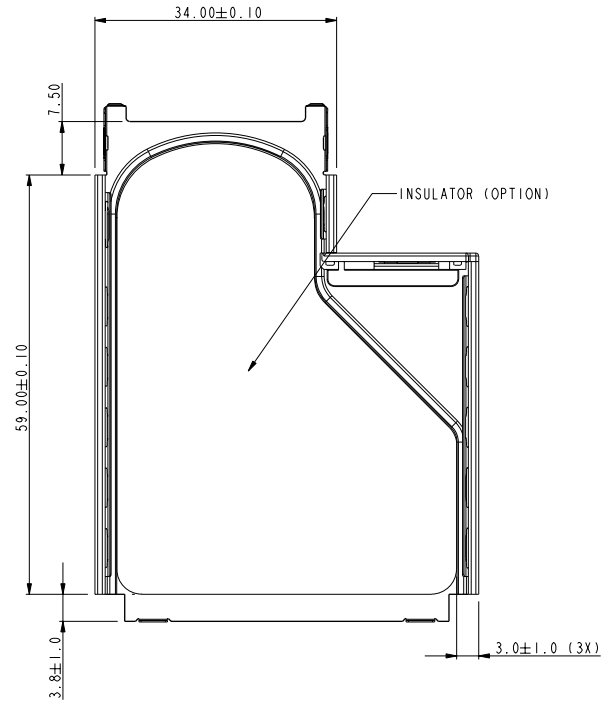

www.fciconnect.com		<input checked="" type="checkbox"/> tolerance	tolerance unless otherwise specified	
			linear	.X ± .30 .XX ± .15 .XXX ± .08
		<input checked="" type="checkbox"/> projection	angles	X° ± 2°
			size	A4
Dr	DAVID TENG	11/16/05	Product family	
Eng	DAVID TENG	01/16/06	Spec ref	*
Chr	PAUL WANG	01/16/06	Material	*
Appr	JOSEPH HSIA	01/16/06	ECN	*
Title		EXPRESSCARD/54 MODULE CARD KIT BOTTOM SHIELD SUB-ASSEMBLY		Rev. E
catalog no		dwg no	10030582	sheet 4 of 4