

Tous droits strictement réservés. Reproduction ou communication à des tiers interdite sous quelque forme que ce soit sans autorisation écrite du propriétaire. Propriété de c FCI. Droits de reproduction FCI.

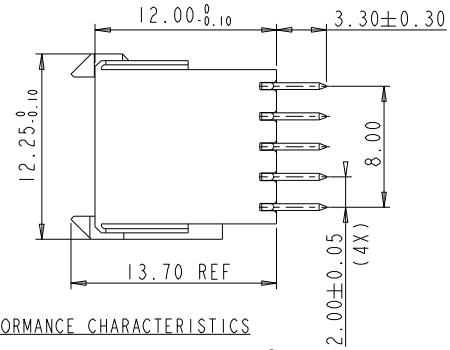

**FCI**

All rights strictly reserved. Reproduction or issue to third parties in any form whatever is not permitted without written authority from the proprietor. Property of FCI. Copyright FCI.

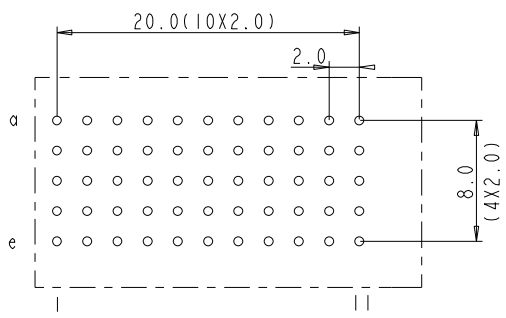
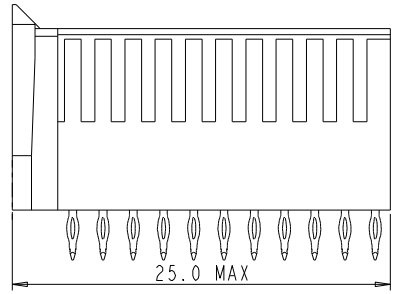
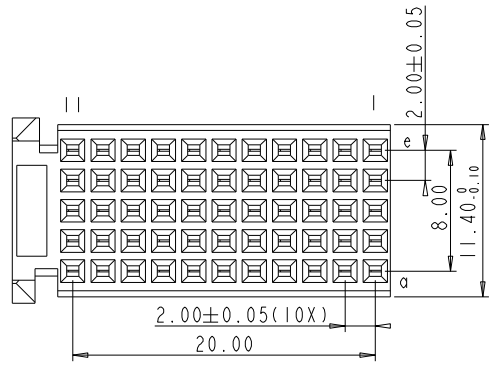

**PERFORMANCE CHARACTERISTICS**

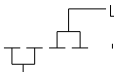
- CURRENT RATING : 1.5A AT 20°C (FULLY LOADED)
- CURRENT RATING : 1 A AT 70°C (FULLY LOADED)
- RATED VOLTAGE : 500 V AC (CONT /CONT)
- OPERATING TEMPERATURE : -55°C TO 125°C
- CONTACT RESISTANCE 20 MΩ MAX
- INSERTION FORCE : 0.75N MAX/CONT
- EXTRACTION FORCE : 0.15N MIN/CONT
- INSULATION RESISTANCE : 10<sup>4</sup> MΩ MIN

- NOTES**
1. "  " LEAD FREE INDICATOR : LF=LEAD FREE  
 "  " PERFORMANCE LEVEL INDICATOR (REF DWG NO.BSC .201844.003)
  2. THIS PRODUCT IS CSA APPROVED.  
THIS PRODUCT IS UL RECOGNIZED.
  3. FOR RECOMMENDED PTH DIMENSIONS REFER DRAWING :BS.A.201572.001
  4. THIS PRODUCT (LF) MEETS EUROPEAN UNION DIRECTIVES AND OTHER COUNTRY REGULATIONS AS DESCRIBED IN GS-22-008

| rev | ecn no                 | dr      | date     |
|-----|------------------------|---------|----------|
| A   | CONVERSION REVISION 00 | KN      | 14-09-01 |
| B   | 104-0114               | Al ex B | 27.11.04 |
| C   | DG05-0278              | Kason   | 02-08-05 |
| -   | -                      | -       | -        |
| -   | -                      | -       | -        |
| -   | -                      | -       | -        |
| -   | -                      | -       | -        |

|                       |          |   |   |                  |
|-----------------------|----------|---|---|------------------|
| Material              |          | Spec ref  |   |                  |
| Mat code              |          | tolerance<br>IDEC±0.2 IDEC<br>2DEC±0.1 2DEC<br>ANGLESET* HOEKEN | projection  | MM               |
| Heatreat              |          |   |  |                  |
| Plating/Finish        |          |   | size A4   | Scale 2.000      |
| Dr M.Pret             | 31-10-97 | Product family MILLIPACS  |   |                  |
| Eng                   |          | Model Name  |   | ECN DG05-0278    |
| Chr                   |          | Model Revision  |   | REL Level        |
| Appr                  |          |   |   |                  |
| <b>FCI</b>            | title    | MILLIPACS 2/TYPE C(W/O LOC.PEG) / NO SHIELDING                  |   | Rev. C           |
| Pro/E file            | catalog  | dwg no  | BSC201907008  |                  |
| PDM: Rev-C            |          | HM2S30PE5100  |   | STATUS: Released |
|                       |          | CUSTOMER DRAWING  |   | sheet 1 of 1     |
| Printed: Sep 30, 2005 |          |   |   |                  |