

Customer Information Sheet

DRAWING No.: M7680-XX - M7683-XX

SHEET 2 OF 2

IF IN DOUBT - ASK

©

NOT TO SCALE

THIRD ANGLE PROJECTION

ALL DIMENSIONS IN mm

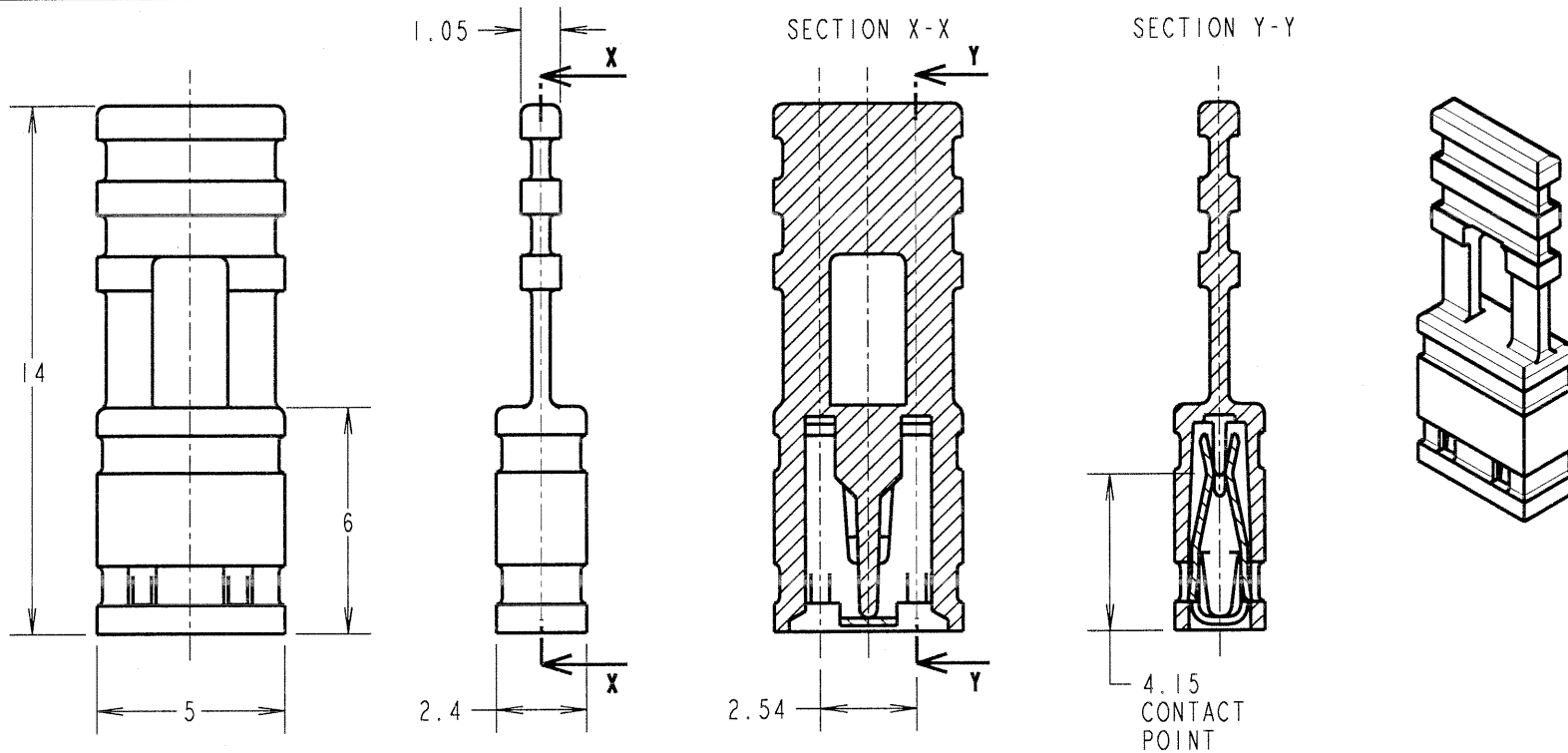

ORDER CODE:
M768X-XX

MOULDING COLOUR
 0 - LT. GREY
 2 - BLACK
 1 - RED
 3 - BLUE

CONTACT FINISH
 05 - GOLD
 46 - 100% TIN

SCALE 4

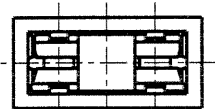

- NOTES:
- MATING PIN = 0.64mm SQUARE, MAXIMUM LENGTH = 5.6mm.
 - FOR FULL ELECTRICAL/MECHANICAL SPECIFICATIONS, SEE COMPONENT SPECIFICATION C003XX (LATEST ISSUE).

SPECIFICATIONS:

MATERIAL:
 MOULDING = POLYESTER UL94V-0
 (SEE ORDER CODE FOR COLOUR)
 CONTACT = PHOSPHOR BRONZE

FINISH:
 05 = 0.13µ GOLD
 46 = 3µ 100% TIN

MECHANICAL:
 DURABILITY = 50 OPERATIONS (TIN)
 300 OPERATIONS (GOLD)
 INSERTION FORCE = 12.5N MAX
 WITHDRAWAL FORCE = 1.0N MIN

ELECTRICAL:
 CURRENT RATING = 3A MAX
 VOLTAGE RATING = 250V AC/DC
 VOLTAGE PROOF = 750V AC
 CONTACT RESISTANCE = 30mΩ MAX (TIN)
 25mΩ MAX (GOLD)

INSULATION RESISTANCE = 1,000MΩ MIN

ENVIRONMENTAL:
 TEMPERATURE RANGE = -40°C TO +85°C

JMB	4	11.04.06	9154
NAME	ISS.	DATE	C/NOTE
APPROVED: <i>[Signature]</i>			
CHECKED: <i>[Signature]</i>			
DRAWN: W. J. BOURNE		CUSTOMER REF.:	
ASSEMBLY DRG:			

HARWIN

HARWIN INC U.S.A. TEL: (812) 542 2540 FAX: (812) 542 2541	HARWIN PLC U.K. TEL: 023 9231 4545 FAX: 023 9231 4590	HARWIN PTE SINGAPORE TEL: 65 6779 4909 FAX: 65 6779 3868
--	--	---

THIS DRAWING AND ANY INFORMATION OR DESCRIPTIVE MATTER SET OUT HEREON ARE CONFIDENTIAL AND COPYRIGHT PROPERTY OF THE HARWIN GROUP AND MUST NOT BE DISCLOSED, LOANED, COPIED OR USED FOR MANUFACTURING, TENDERING OR FOR ANY OTHER PURPOSE WITHOUT THEIR WRITTEN PERMISSION.

TOLERANCES
 X. = ±1mm
 X.X = ±0.25mm
 X.XX = ±0.10mm
 X.XXX = ±0.01mm
 ANGLES = ±5°
 UNLESS STATED

MATERIAL:
 SEE TABLE

FINISH:
 SEE TABLE

S/AREA:
 mm²

TITLE: 2.54mm PITCH
 CLOSED-BOX JUMPER SOCKET
 WITH HANDLE (14mm)

DRAWING NUMBER:
M7680-XX - M7683-XX

SHT
 2 OF 2