

DRAWING FOR REFERENCE: This is subject to change without notice  
05/31/2013

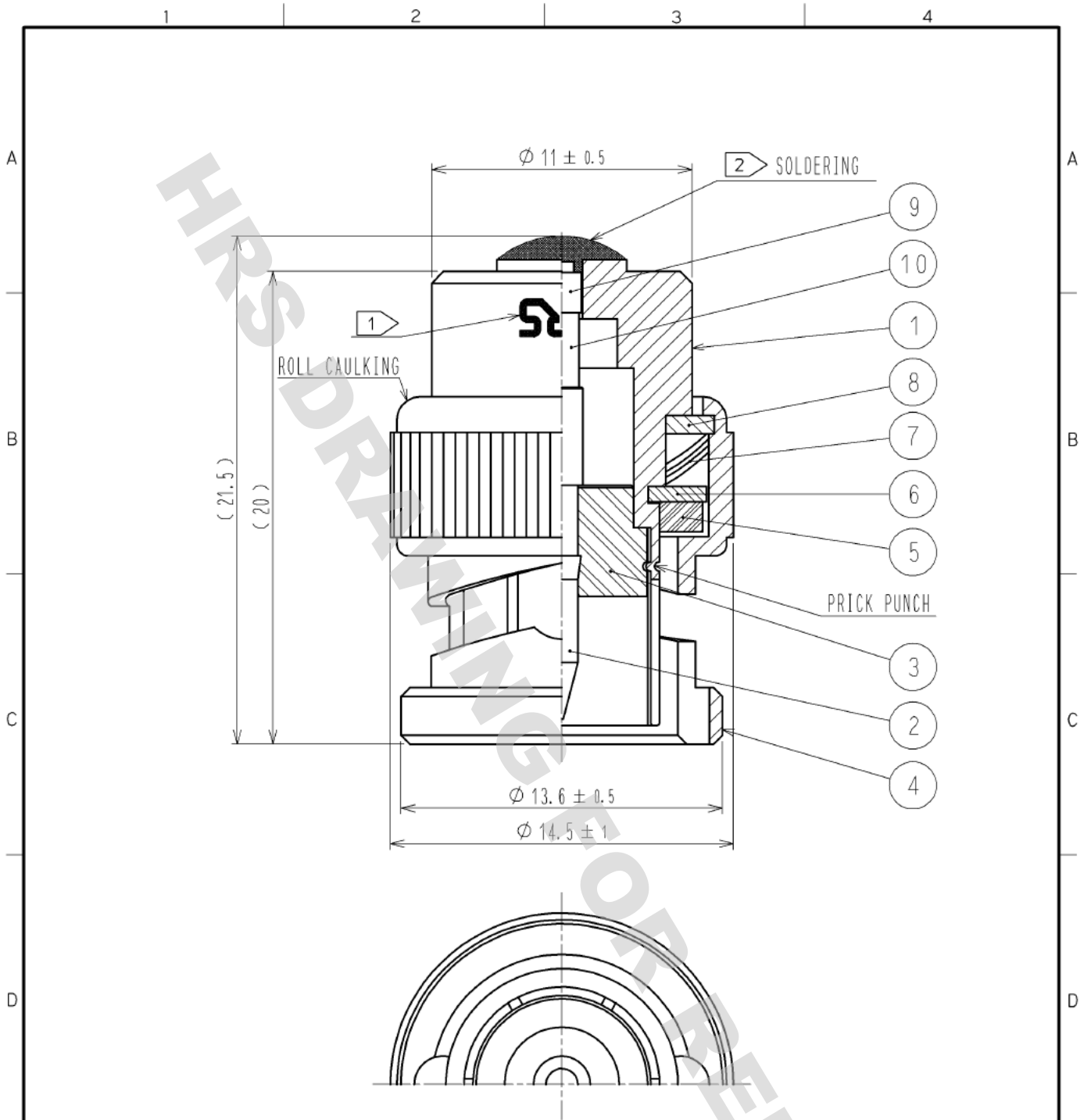

- NOTES
- ① HRS MARKING SHALL BE INDICATED AT THE POSITION AS SHOWN.  
75Ω AT THE REVERSE SIDE.
  - ② USE LEAD FREE SOLDER ( Sn3.0Ag0.5Cu ).

5	SILICONE RUBBER		10	RESISTANCE	75Ω
4	BRASS	NICKEL PLATING	9	BRASS	GOLD PLATING
3	PTFE		8	BRASS	NICKEL PLATING
2	BRASS	GOLD PLATING	7	BERYLLIUM COPPER	SILVER PLATING
1	BRASS	NICKEL PLATING	6	BRASS	NICKEL PLATING
NO.	MATERIAL	FINISH , REMARKS	NO.	MATERIAL	FINISH , REMARKS

UNITS mm		SCALE 4 : 1	COUNT 	DESCRIPTION OF REVISIONS	DESIGNED	CHECKED	DATE
HIROSE ELECTRIC CO., LTD.				APPROVED : MT. SHIBUTANI 12. 04. 20 CHECKED : TK. SAWAGUCHI 12. 04. 20 DESIGNED : KY. SHIMIZU 12. 04. 19 DRAWN : KY. SHIMIZU 12. 04. 19	DRAWING NO. EDC4-030447-02 PART NO. BNC-TMP-05(75)(50) CODE NO. CL353-0100-5-50	1/1	