

May.1.2017 Copyright 2017 HIROSE ELECTRIC CO., LTD. All Rights Reserved.

1		2			3			4		
COUNT	DESCRIPTION OF REVISIONS	BY	CHKD	DATE	COUNT	DESCRIPTION OF REVISIONS	BY	CHKD	DATE	
1	DIS-C-000585	T.K	E.K	07.07.27						

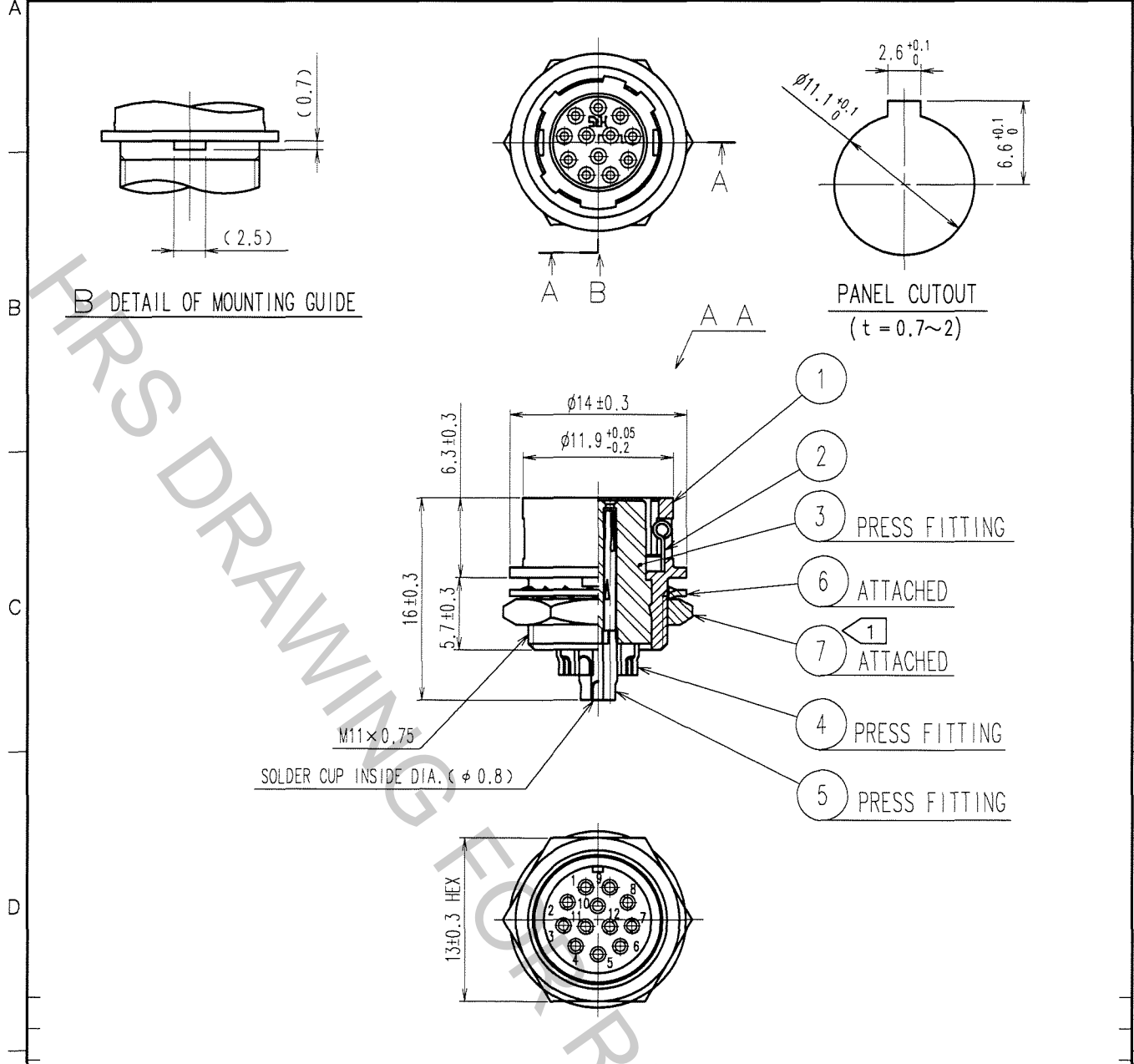

NOTE ① THE RECOMMENDED CLAMP TORQUE OF REF. NO. ⑦ TO BE 2 N · m.
 LOCTITE 242, HENKEL JAPAN OR EQUIVALENT IS RECOMMENDED TO
 PREVENT REF. NO. ⑦ FROM LOOSENING.

NO.	MATERIAL	FINISH, REMARKS	NO.	MATERIAL	FINISH, REMARKS
3	POLYAMIDE	(BLACK) UL94V-0	7	BRASS	NICKEL PLATING
2	STAINLESS STEEL		6	PHOSPHOR BRONZE	NICKEL PLATING
1	ZINC ALLOY	MATTE FINISH NICKEL PLATED	5	PHOSPHOR BRONZE	SILVER PLATING 2μ m min.
			4	PHOSPHOR BRONZE	

CODE NO. (OLD) CL	DRAWN D. MATSUNE '05 10 01	DESIGNED D. MATSUNE '05 10 01	CHECKED E. KUNII '05 10 03	APPROVED M. SATO '05 10 14	RELEASED
----------------------	----------------------------------	-------------------------------------	----------------------------------	----------------------------------	----------

TO
R

	DRAWING NO. EDC4-010387-71	PART NO. HR10A-10R-12S(71)
	 HIROSE ELECTRIC CO., LTD.	CODE NO. CL110-0403-2-71