

Oct.1.2019 Copyright 2019 HIROSE ELECTRIC CO., LTD. All Rights Reserved.
 In case of consideration for using Automotive equipment / device which demand high reliability, kindly contact our sales window correspondents.

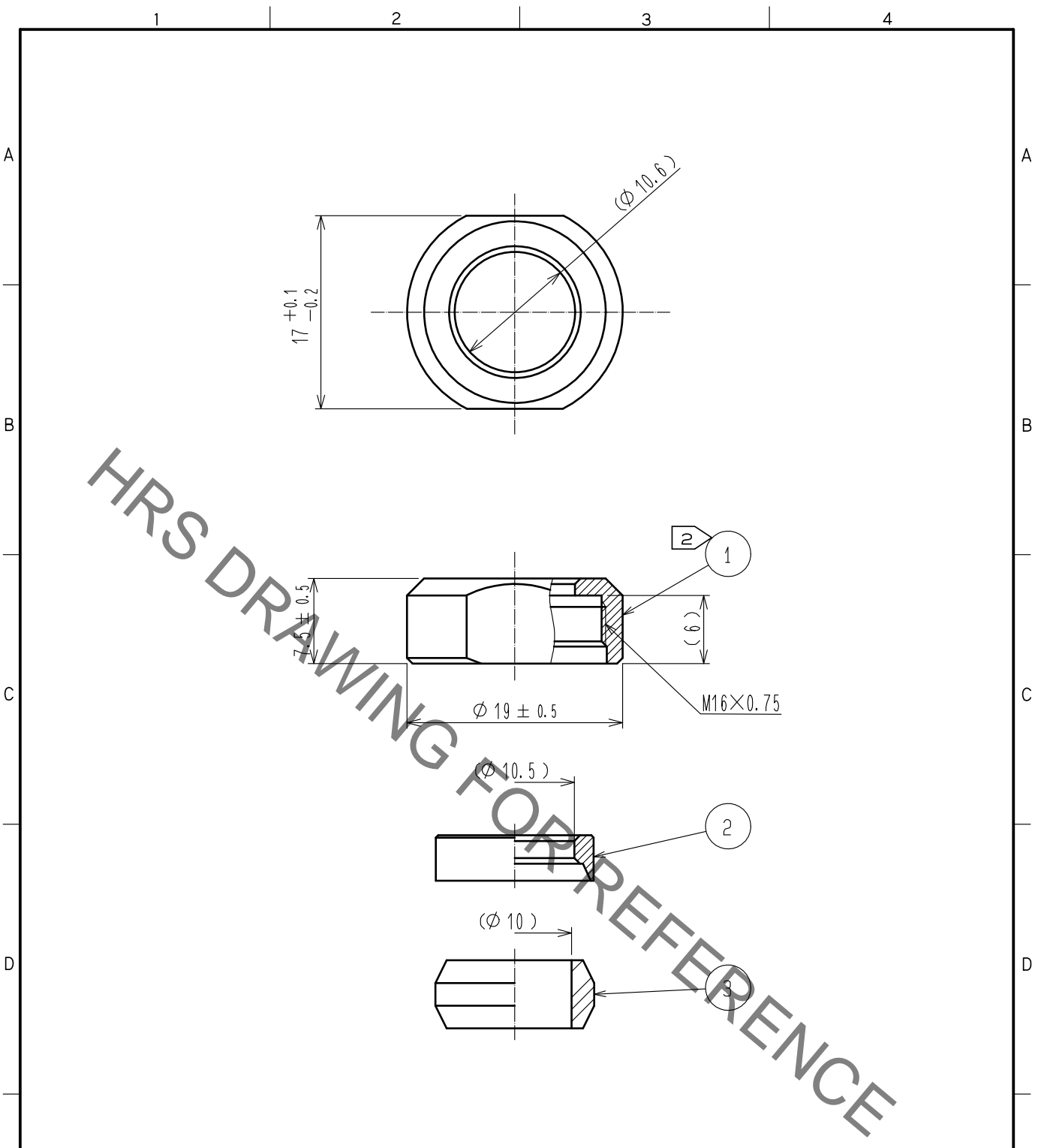

- Notes
- 1 This product is delivered disassembled.
 - 2 The recommended clamp torque of Ref.No. ① to be 2 to 2.5N · m. LOCTITE 263, Henkel Japan or equivalent is recommended to prevent Ref.No. ① from loosening.
 - 3 The cable pull and twisting strength and other characteristics may differ, depending on the cable structure. please before the use.

2	BRASS	NICKEL PLATING		3	SILICONE RUBBER (BLACK)				
1	BRASS	CHROME PLATING							
NO.	MATERIAL	FINISH	REMARKS	NO.	MATERIAL	FINISH	REMARKS		
UNITS mm		SCALE 2 : 1	COUNT 	DESCRIPTION OF REVISIONS		DESIGNED	CHECKED	DATE	
HIROSE ELECTRIC CO., LTD.		APPROVED	·HY. KOBAYASHI	15.08.18	DRAWING NO.	EDC-110459-72-00			
		CHECKED	·HY. KOBAYASHI	15.08.18	PART NO.	JR13WCCA-10(72)			
		DESIGNED	·HY. KISHI	15.08.18	CODE NO.	CL114-2075-1-72		1	1
		DRAWN	·HY. KISHI	15.08.18					