

Oct.1.2019 Copyright 2019 HIROSE ELECTRIC CO., LTD. All Rights Reserved.
 In case of consideration for using Automotive equipment / device which demand high reliability, kindly contact our sales window correspondents.

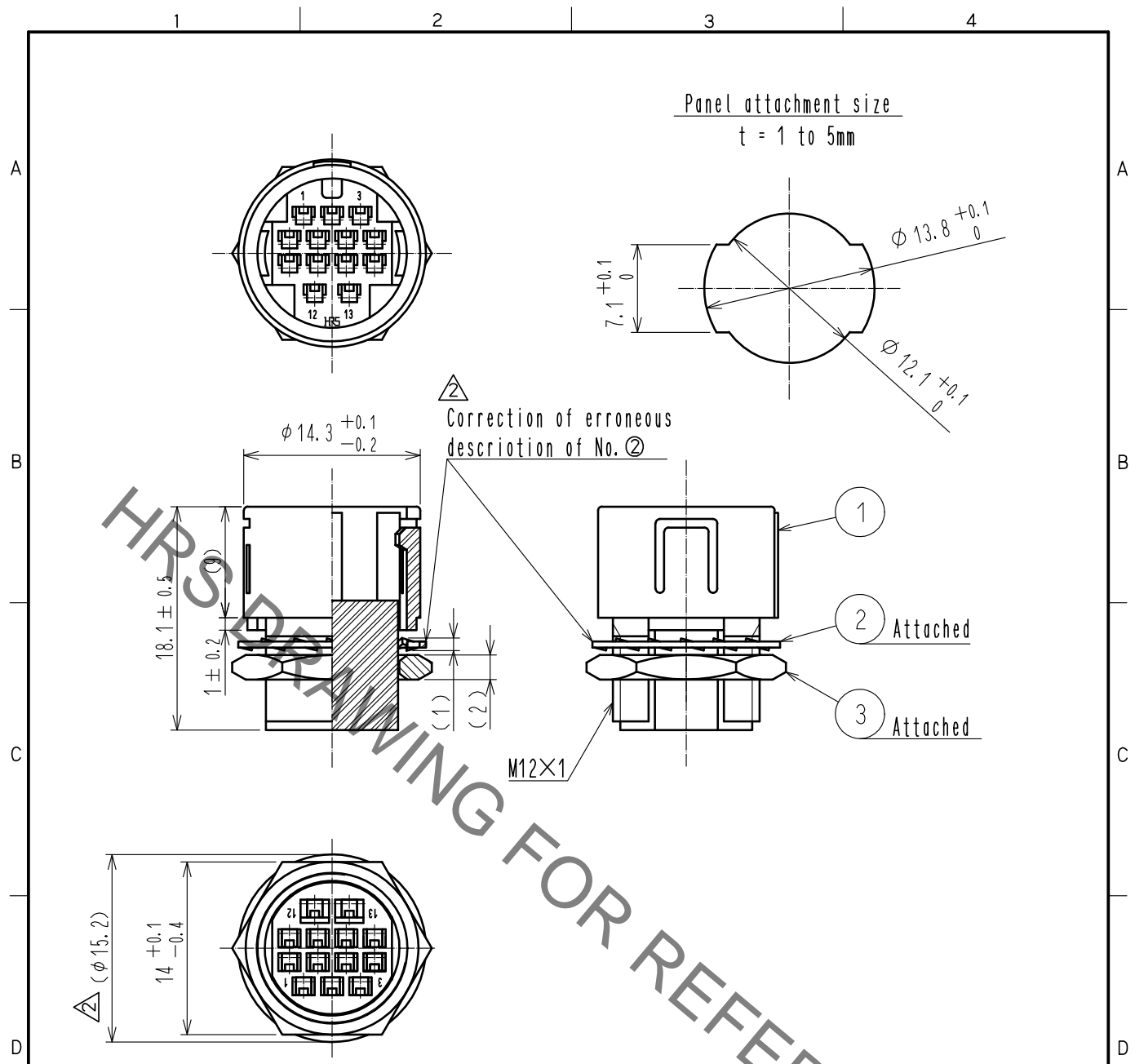

Notes 1 Adapt crimp contact
 Contact No.1 to 11
 RP13-PC-222(CL113-0141-7)(Applicable wire : AWG#24 to #28)
 Contact No.12,13
 RP13-PC-212(CL113-0140-4)(Applicable wire : AWG#18 to #22)
 2 Extraction tool : RP13-PC-TP(CL150-0021-5)

2	Steel	Nickel Plating					
1	Polycarbonate	(Black) UL94V-0	3	Brass	Nickel Plating		
NO.	MATERIAL	FINISH . REMARKS	NO.	MATERIAL	FINISH . REMARKS		
UNITS mm		SCALE 2 : 1	COUNT 2	DESCRIPTION OF REVISIONS DIS-C-00002172	DESIGNED TY. SUZUKI	CHECKED HY. KOBAYASHI	
HIROSE ELECTRIC CO., LTD.		APPROVED :MR. YOSHIDA	05.01.05	DRAWING NO.	EDC-009800-71-71		
		CHECKED :MO. SATOH	05.01.05	PART NO.	RP13A-12RB-13PC(71)		
		DESIGNED :YH. YAMADA	05.01.05	CODE NO.	CL113-0185-2-71	1/1	
		DRAWN :YH. YAMADA	05.01.05				