

Sep.1.2019 Copyright 2019 HIROSE ELECTRIC CO., LTD. All Rights Reserved.
 In case of consideration for using Automotive equipment / device which demand high reliability, kindly contact our sales window correspondents.

PCB LAYOUT

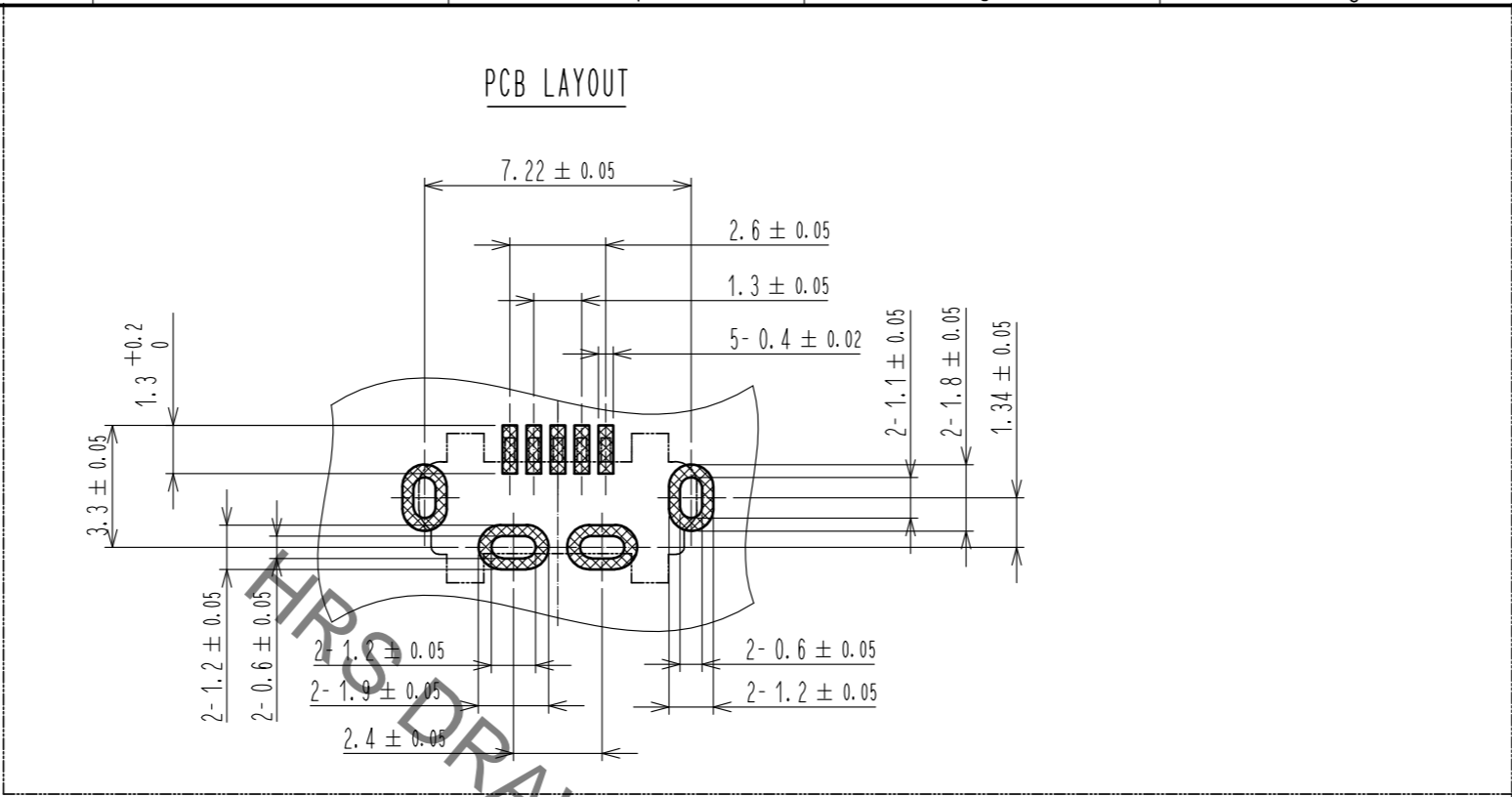

PICK AND PLACE CAP

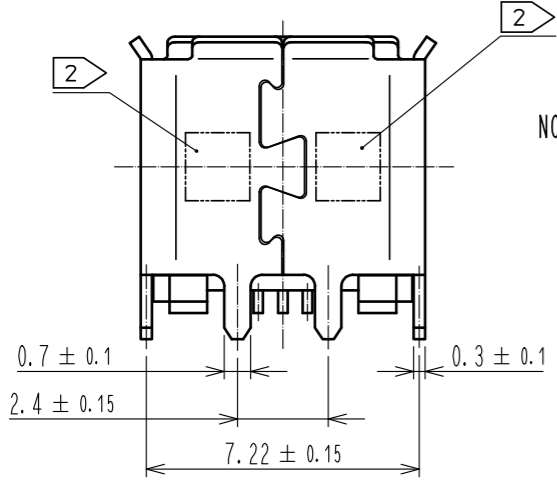
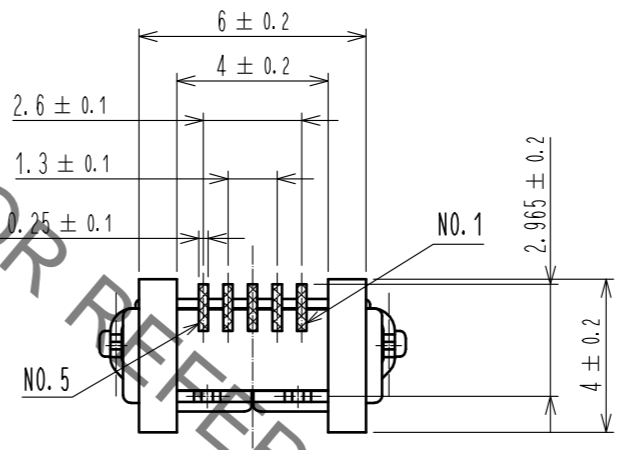
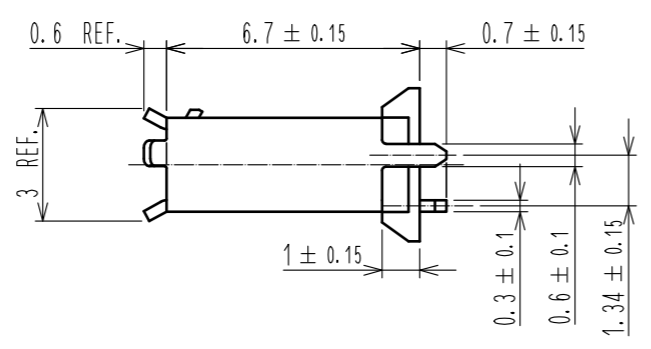
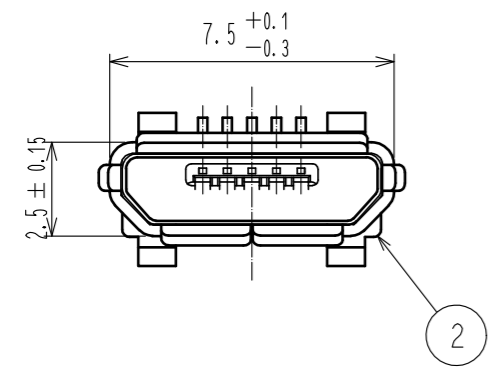
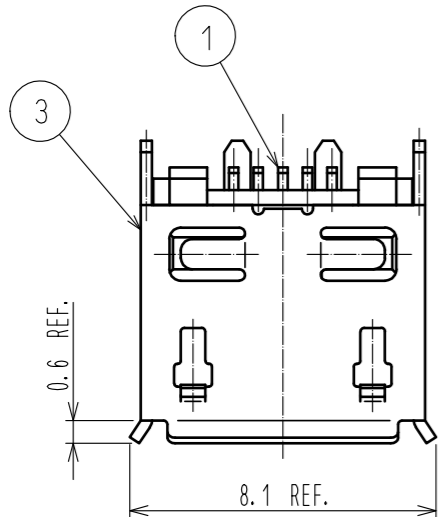
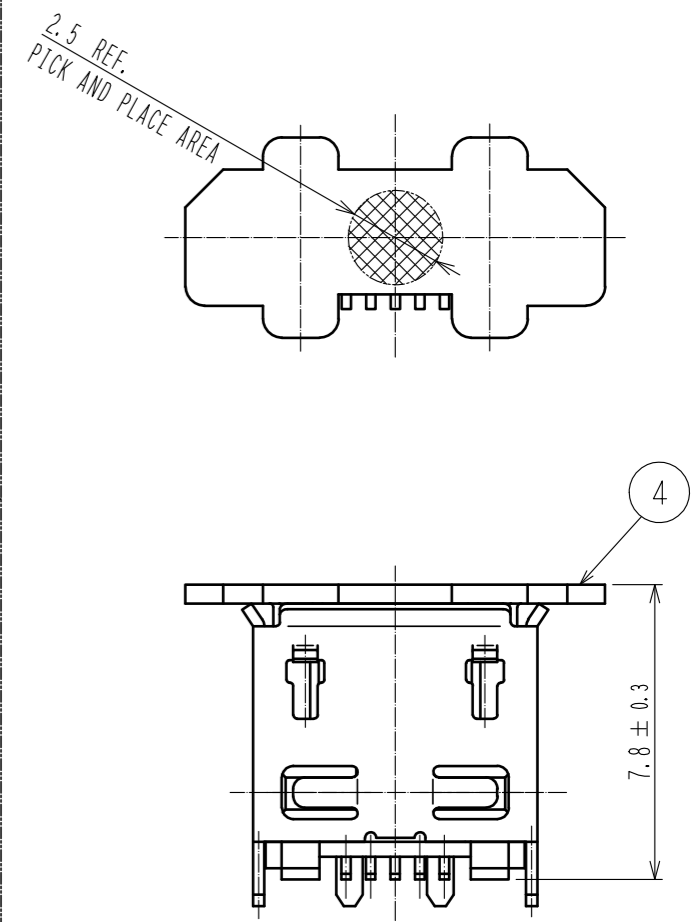

- NOTE
- 1 CO-PLANARITY IS WITHIN 0.08.
 - 2 LOT No. SHALL BE INDICATED AT THE POSITION AS SHOWN.
 - 3 PLATING
 CONTACT AREA : GOLD PLATE 0.75 μm MIN.
 LEAD AREA : GOLD PLATE 0.05 μm MIN.
 UNDER PLATING : NICKEL 2 μm MIN.
 - 4 PACKING
 300 PCS PER TRAY.
 - 5 AS FOR PART No. 3, THE PERFORMANCE REMAINS GOOD EVEN IF THERE IS A RUBBING WOUND BY THE ASSEMBLY PROCESS. AND THE PERFORMANCE REMAINS GOOD EVEN IF THERE IS A DIFFERENCE OF THE COLOR OF PLATING WITH THE MANUFACTURING LOT.

2	LCP	BLACK	UL94V-0	5	PS			
1	COPPER ALLOY	3		4	POLYAMIDE RESIN			
				3	STAINLESS STEEL	UNDER PLATING: NICKEL 0.2 μm MIN. OVER PLATING : TIN 1μm MIN. LUBRICANT		
NO.	MATERIAL	FINISH	REMARKS	NO.	MATERIAL	FINISH	REMARKS	
UNITS	mm	SCALE	5 : 1	COUNT	DESCRIPTION OF REVISIONS	DESIGNED	CHECKED	DATE
HRS HIROSE ELECTRIC CO., LTD.		APPROVED	NM. NISHIMATSU	15.10.27	DRAWING NO. EDC-126723-30-00			
		CHECKED	KN. ICHIKAWA	15.10.27	PART NO. ZX80-B-5P(30)			
		DESIGNED	TS. ITO	15.10.27	CODE NO. CL242-0051-0-30			
		DRAWN	AK. AKIYAMA	15.10.27	1/2			

Sep.1.2019 Copyright 2019 HIROSE ELECTRIC CO., LTD. All Rights Reserved.
In case of consideration for using Automotive equipment / device which demand high reliability, kindly contact our sales window correspondents.

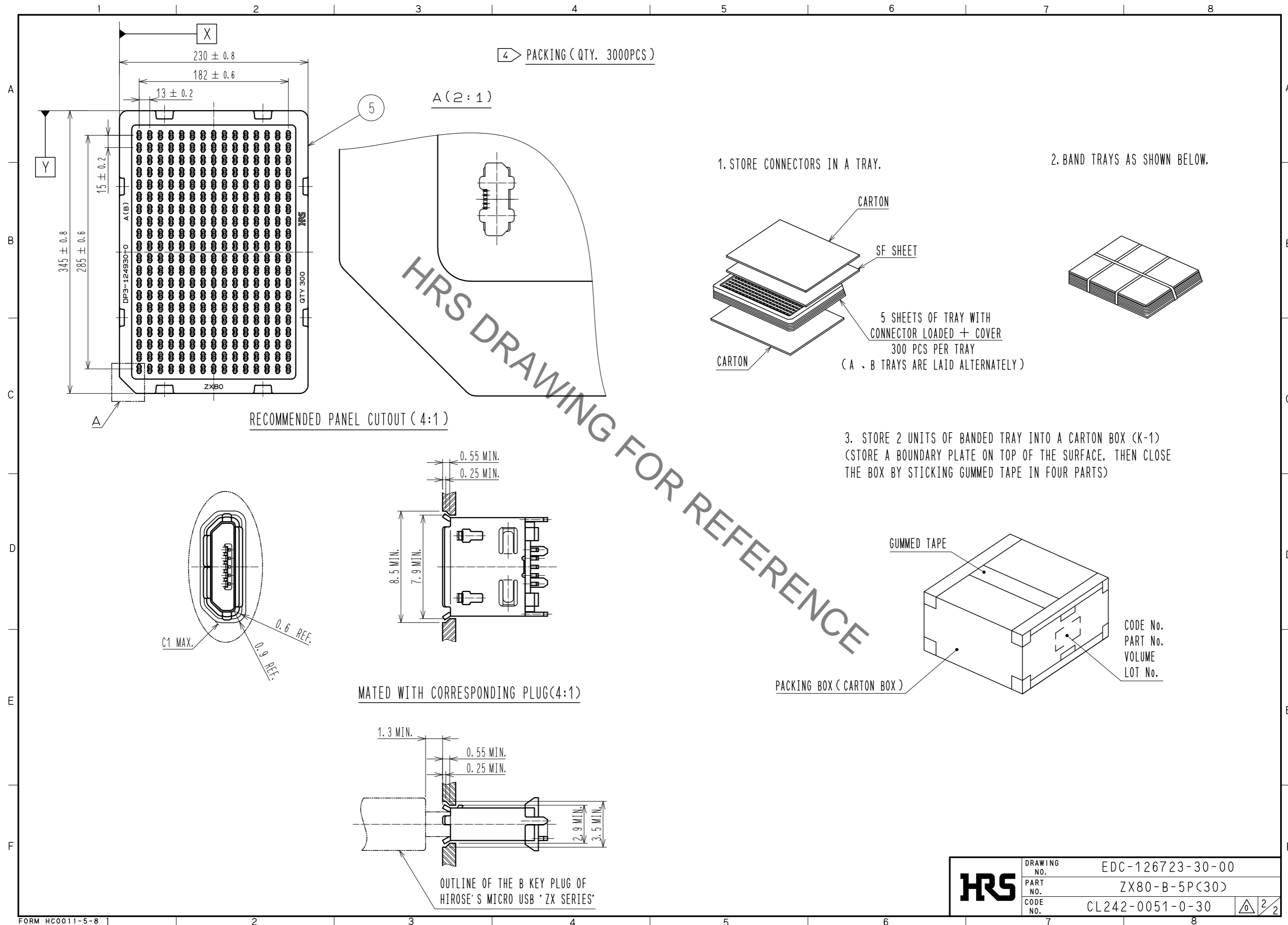

4 PACKING (QTY. 3000PCS)

A (2:1)

RECOMMENDED PANEL CUTOUT (4:1)

MATED WITH CORRESPONDING PLUG(4:1)

OUTLINE OF THE B KEY PLUG OF HIROSE'S MICRO USB 'ZX SERIES'

1. STORE CONNECTORS IN A TRAY.

2. BAND TRAYS AS SHOWN BELOW.

5 SHEETS OF TRAY WITH CONNECTOR LOADED + COVER
300 PCS PER TRAY
(A . B TRAYS ARE LAID ALTERNATELY)

3. STORE 2 UNITS OF BANDED TRAY INTO A CARTON BOX (K-1)
(STORE A BOUNDARY PLATE ON TOP OF THE SURFACE, THEN CLOSE THE BOX BY STICKING GUMMED TAPE IN FOUR PARTS)

PACKING BOX (CARTON BOX)

HRS	DRAWING NO.	EDC-126723-30-00	2/2
	PART NO.	ZX80-B-5P(30)	
	CODE NO.	CL242-0051-0-30	