

Jun.1.2020 Copyright 2020 HIROSE ELECTRIC CO., LTD. All Rights Reserved.
In case of consideration for using Automotive equipment / device which demand high reliability, kindly contact our sales window correspondents.

DRAWING FOR REFERENCE
This is subject to change without notice

COUNT	DESCRIPTION OF REVISIONS	B	Y	CHKD	DATE	COUNT	DESCRIPTION OF REVISIONS	B	Y	CHKD	DATE
2	RE-6-0742			LYJ	JHW	16.09.27					
3	RE-6-0806			MSH	JHW	17.01.05					

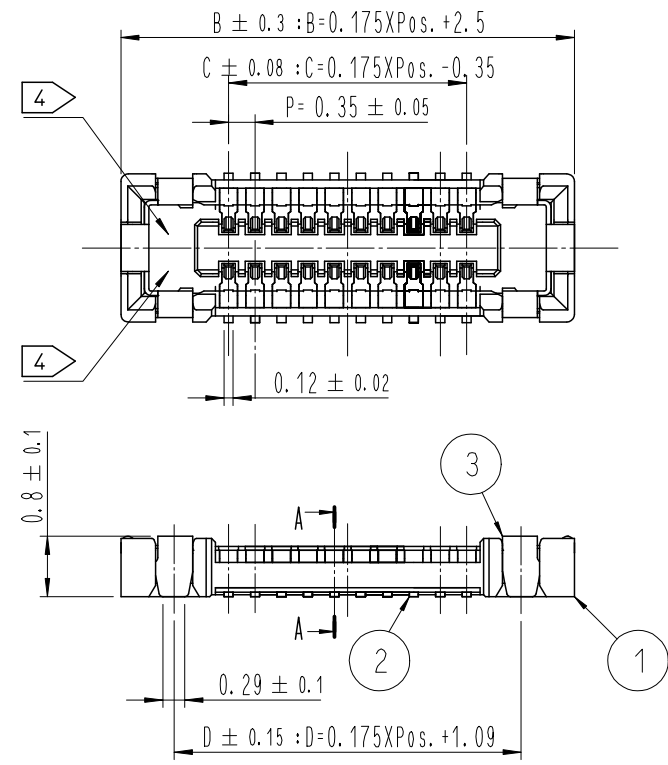

A-A(50:1)

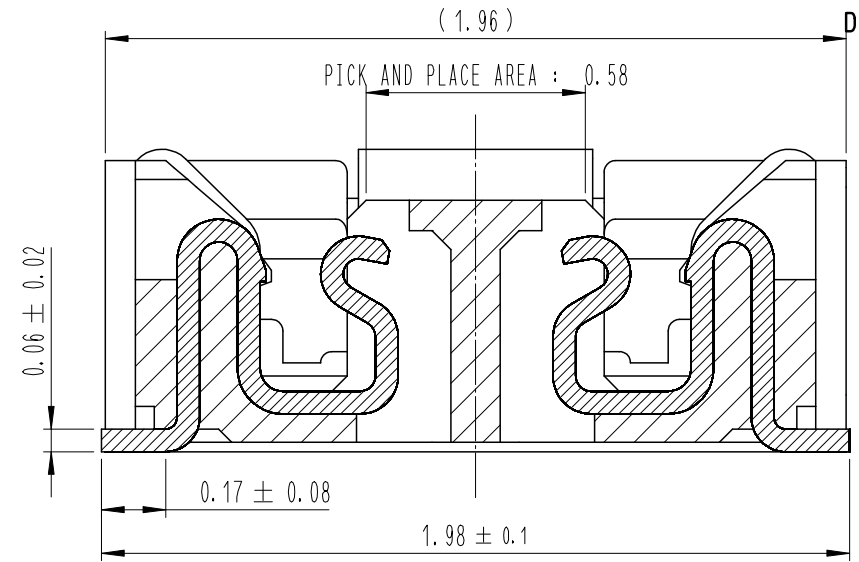

- NOTE
- 1. ALL LEAD CO-PLANARITY SHALL BE 0.08mm MAX.
 - 2. CONTACT PLATING SPECIFICATIONS.
CONTACT AREA : GOLD 0.05 μm MIN.
SMT LEAD : GOLD 0.05 μm MIN.
UNDERPLATING : NICKEL 1 μm MIN.
(SURFACE : SEALING)
 - 3. METAL FITTING PLATING SPECIFICATIONS.
SMT LEAD : GOLD 0.05 μm MIN.
UNDERPLATING : NICKEL 1 μm MIN.
(SURFACE : SEALING)
 - 4. HRS MARK AND CAV NO. IS INDICATED IN APPROX POSITION SHOWN.

HRS DRAWING FOR REFERENCE

ENGAGEMENT FIGURE (50:1)

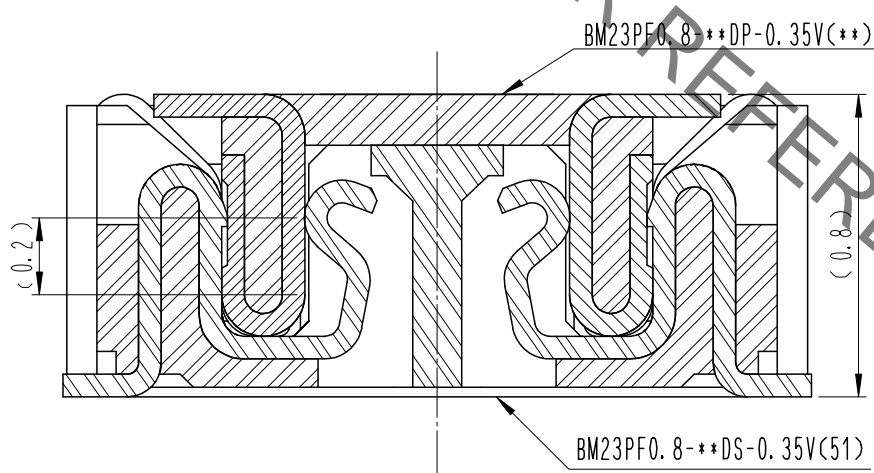

PART No.	CODE No.	POS.	B	C	D
BM23PF0.8-10DS-0.35V(51)	-	10	4.25	1.40	2.84
BM23PF0.8-14DS-0.35V(51)	-	14	4.95	2.10	3.54
BM23PF0.8-20DS-0.35V(51)	-	20	6.00	3.15	4.59
BM23PF0.8-24DS-0.35V(51)	-	24	6.70	3.85	5.29
BM23PF0.8-40DS-0.35V(51)	-	40	9.50	6.65	8.09
BM23PF0.8-42DS-0.35V(51)	-	42	9.85	7.00	8.44
BM23PF0.8-46DS-0.35V(51)	-	46	10.55	7.70	9.14
BM23PF0.8-54DS-0.35V(51)	-	54	11.95	9.10	10.54

NO.	MATERIAL	FINISH , REMARKS	NO.	MATERIAL	FINISH , REMARKS
4	PS	CLEAR (EMBOSSD CARRIER TAPE)			
3	COOPER ALLOY	3	7	PS	CLEAR (REINFORCEMENT COLLAR)
2	COOPER ALLOY	2	6	PS	BLACK (PLASTIC REEL)
1	LCP	UL94 V-0, BLACK	5	POLYESTER	CLEAR (COVER TAPE)

REMARKS	DRAWN	DESIGNED	CHECKED	APPROVED	RELEASED
	Y. J. LEE	Y. J. LEE	H. W. JO	T. S. KANG	15.11.23
	15.11.23	15.11.23	15.11.23	15.11.23	

CODE NO. (OLD)	DRAWING NO. EDC3-*****	PART NO. BM23PF0.8-**-DS-0.35V(51)
SCALE 10:1	HRS HIROSE KOREA CO.,LTD.	CODE NO. CL 66**-*****-***
UNITS mm		1/3

Jun.1.2020 Copyright 2020 HIROSE ELECTRIC CO., LTD. All Rights Reserved.
In case of consideration for using Automotive equipment / device which demand high reliability, kindly contact our sales window correspondents.

6 RECOMMENDED PCB LAYOUT

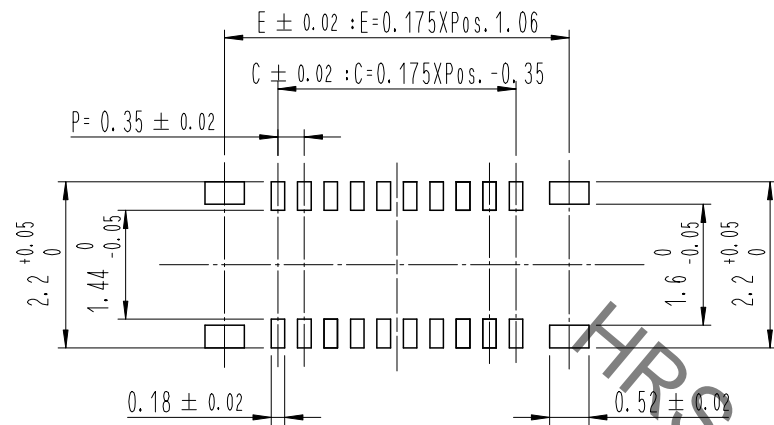

POS.	C	E
10	1.40	2.81
14	2.10	3.51
20	3.15	4.56
24	3.85	5.26
40	6.65	8.06
42	7.00	8.41
46	7.70	9.11
54	9.10	10.51

RECOMMENDED METAL MASK DIMENSIONS
MATAL MASK THICKNESS : 100 μm

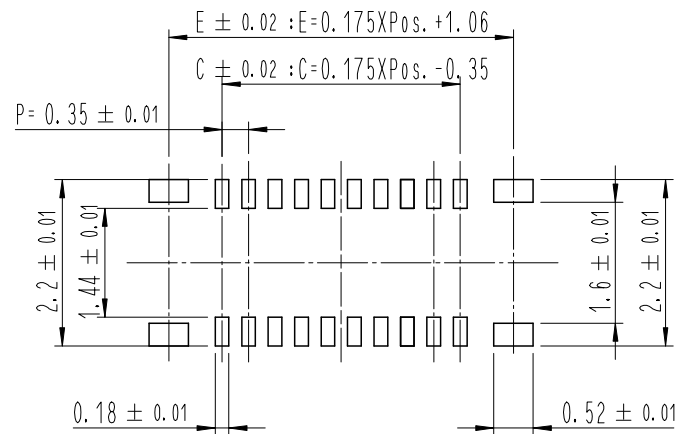

5 RECOMMENDED REFLOW TEMPERATURE PROFILE USING LEAD-FREE SOLDER PASTE.

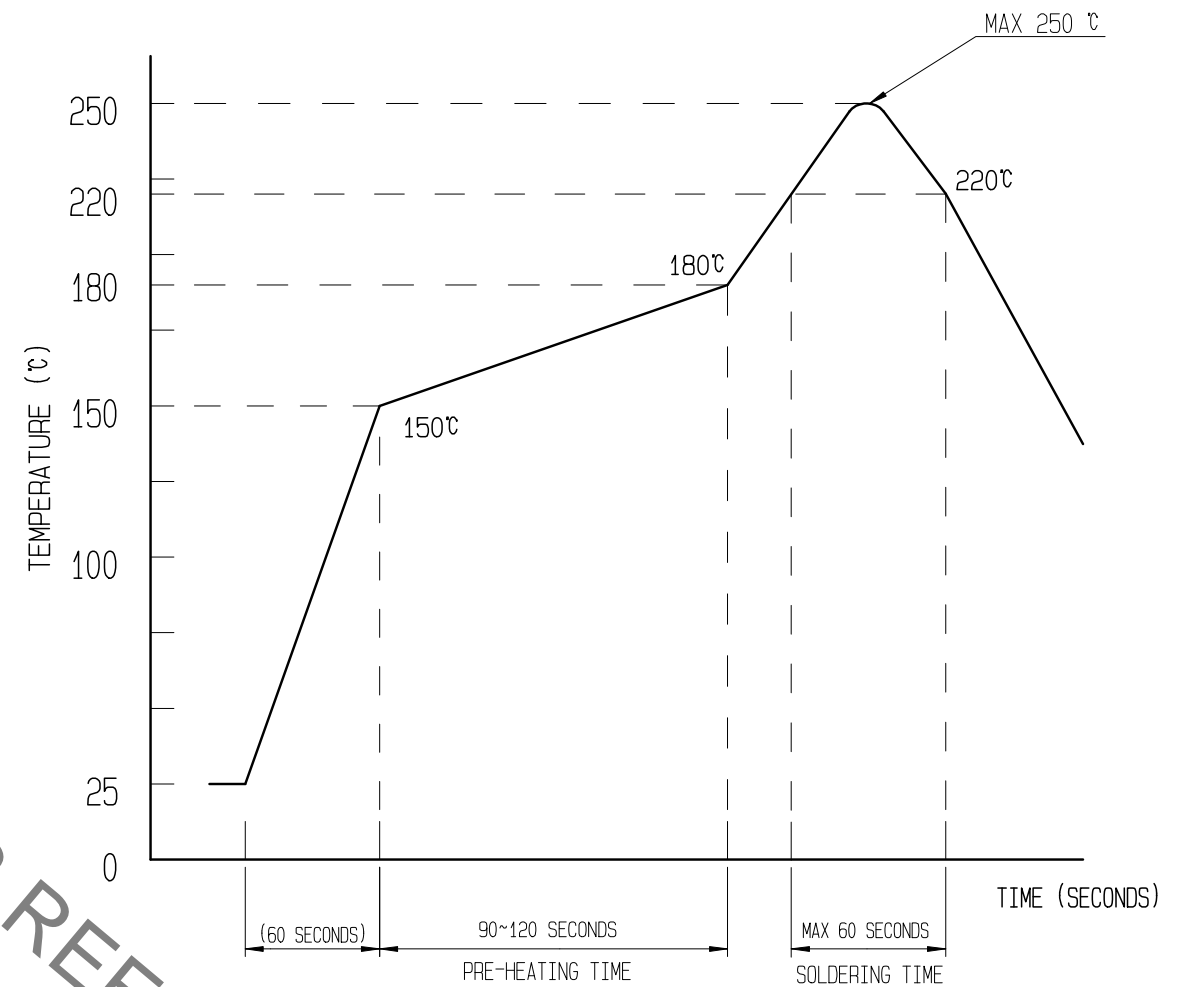

REFLOW METHOD:IR REFLOW
NUMBER OF REFLOW CYCLES:2 CYCLES MAX.
1)REFLOW TIME
DURATION ABOVE 220°C, 60 SEC MAX.
(PEAK TEMPERATURE:250°C MAX)
2)PRE-HEAT TIME
PRE-HEAT TEMPERATURE(MIN):150°C
PRE-HEAT TEMPERATURE(MAX):180°C
PRE-HEAT TIME:90-120 SEC.

- 5 THIS TEMPERATURE PROFILE IS PER THE CONDITIONS SHOWN ABOVE. ADDITIONAL FACTORS, SUCH AS SOLDER PASTE TYPE, PCB SIZE AND OTHER MOUNTED COMPONENTS COULD AFFECT THE PROFILE, THEREFORE, A THOROUGH EVALUATION OF MOUNTING CONDITION IS REQUIRED PRIOR TO PRODUCTION. TEMPERATURE IS MEASURED AT CONTACT LEAD.
- 6 PLEASE CONTACT US IN CASE YOU WILL MAKE DIFFERENT SETTINGS FROM OUR RECOMMENDATION.

	DRAWING NO.	EDC3-*****	PART NO.	BM23PF0.8-**DS-0.35V(51)
	SCALE	10:1	CODE NO	CL 66**-*****-***
	UNITS	mm		

Jun.1.2020 Copyright 2020 HIROSE ELECTRIC CO., LTD. All Rights Reserved.
 In case of consideration for using Automotive equipment / device which demand high reliability, kindly contact our sales window correspondents.

EMBOSSED CARRIER TAPE PACKAGING (5:1)

△ POS.	F	G	H	J	K
10	16	7.5	4.36	17.5	21.5
14	16	7.5	5.06	17.5	21.5
20	16	7.5	6.11	17.5	21.5
24	16	7.5	6.81	17.5	21.5
40	24	11.5	9.61	25.5	29.5
42	24	11.5	9.96	25.5	29.5
46	24	11.5	10.66	25.5	29.5
54	24	11.5	12.06	25.5	29.5

L-L (5:1)

N (10:1)

M-M (5:1)

DIRECTION OF UNREELING →

STYLE AND DIMENTION OF REEL (FREE)

DETAIL OF PART No. LABEL

—	SUPPLIER
—	QUANTITY
—	PART NO.
—	CODE NO.
—	DATE OF MANUFACTURED
—	生産月日
—	年月日
—	図番
—	** ** *
—	品名
—	BM23PF0.8-**-DS-0.35V(51)
—	納入数量
—	10,000個
—	納入者
—	HIROSE KOREA

9 TAPING(FREE)

Q-Q (FREE)

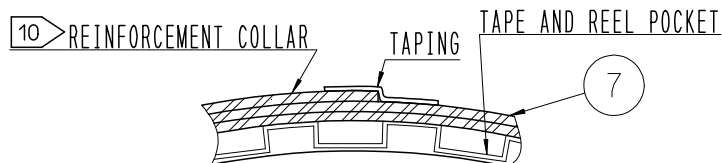

Part No. LABEL

Φ 1.5 SPROCKET HOLE FAR SIDE

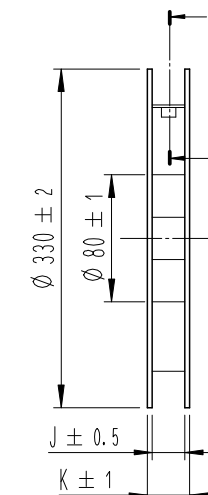
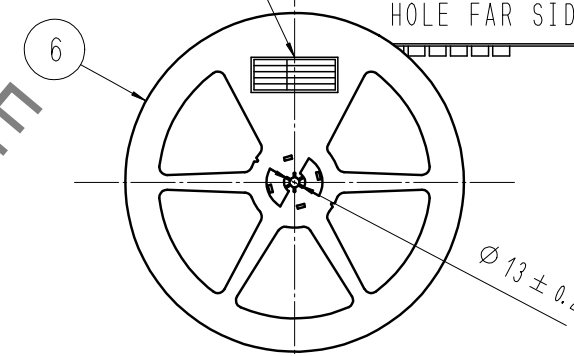

7 . PER REEL 10,000 CONNECTORS.

8 . THE DIMENSIONS IN PARENTHESES ARE FOR REFERENCE.

9 REFER TO JIS C 0806, IEC-60286-3 (PACKAGING OF COMPONENTS FOR AUTOMATIC HANDLING)

10 AFTER PACKAGING. ROLL 2 METERS OF THE REINFORCEMENT COLLAR TO OUTER CIRCUMFERENCE OF TAPE AND REEL POCKET. AND TAPE DOWN AT THE END THE COLLAR.

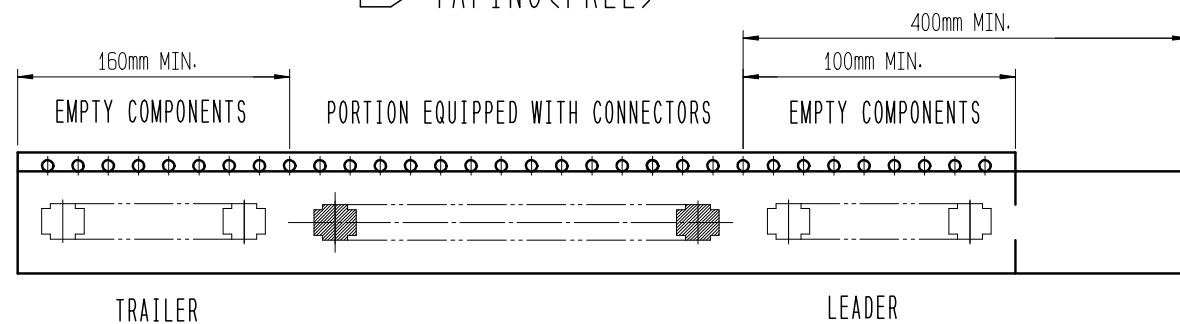

 SCALE 10:1 UNITS mm	DRAWING NO. EDC3-*****	PART NO. BM23PF0.8-**-DS-0.35V(51)
	HIROSE KOREA CO., LTD.	
	CODE NO. CL 66**-*****-***	3/3