

Jun.1.2020 Copyright 2020 HIROSE ELECTRIC CO., LTD. All Rights Reserved.  
In case of consideration for using Automotive equipment / device which demand high reliability, kindly contact our sales window correspondents.

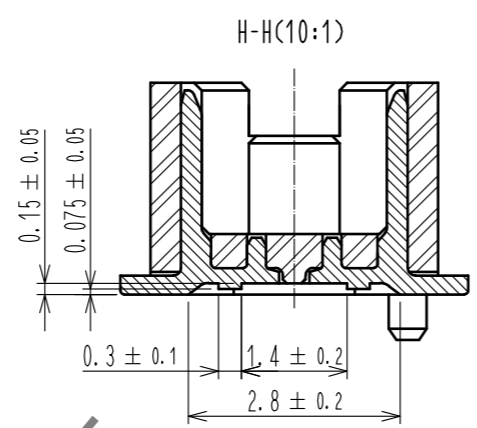
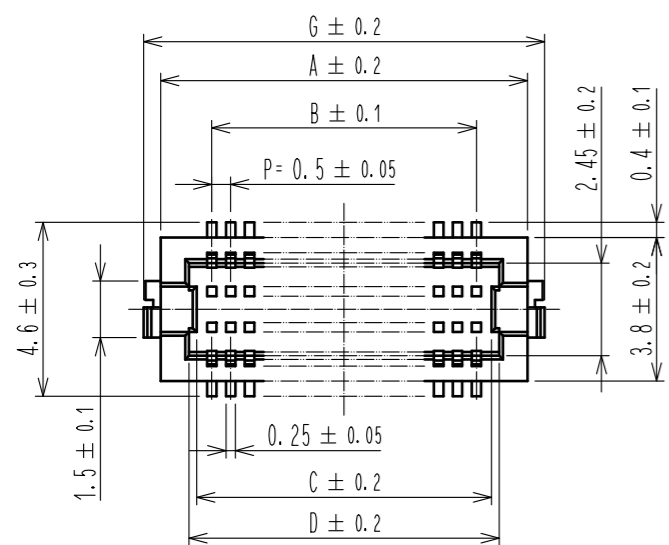

CODE No.	CONTACT	A	B	C	D	E	F	G
CL537-0028-7-86	20	7.2	4.5	5.3	5.7	6.6	5.3	8.1
CL537-0030-9-86	30	9.7	7.0	7.8	8.2	9.1	7.8	10.6
CL537-0031-1-86	36	11.2	8.5	9.3	9.7	10.6	9.3	12.1
CL537-0032-4-86	40	12.2	9.5	10.3	10.7	11.6	10.3	13.1
CL537-0034-0-86	50	14.7	12.0	12.8	13.2	14.1	12.8	15.6
CL537-0036-5-86	60	17.2	14.5	15.3	15.7	16.6	15.3	18.1

RECOMMENDED METAL MASK (10:1)

RECOMMENDED PATTERN (10:1)

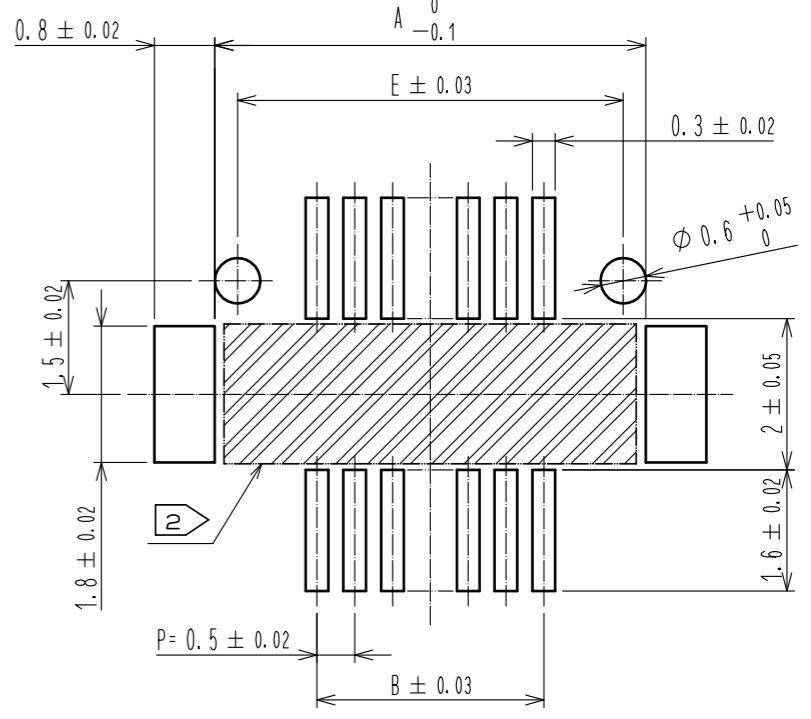
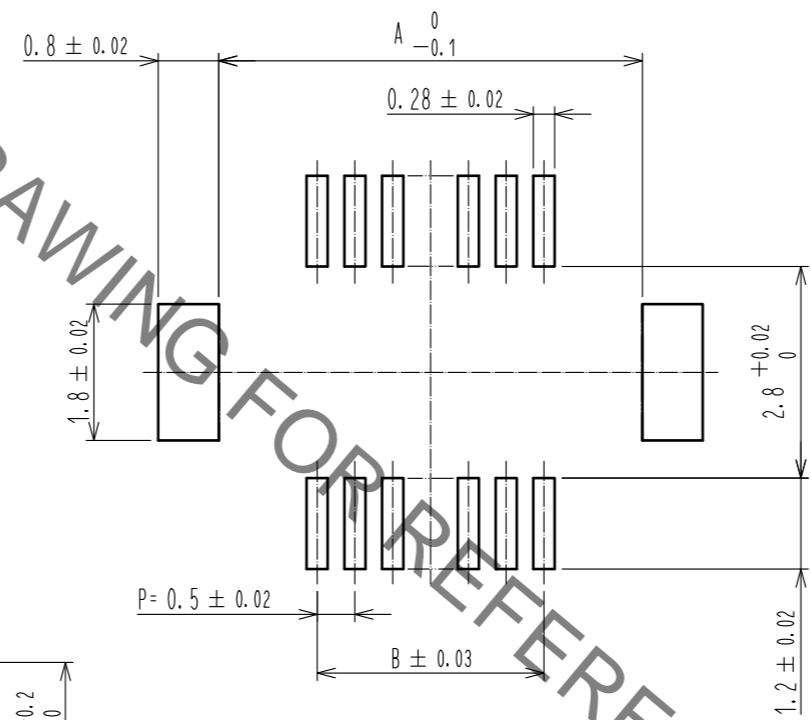

RECOMMENDED THICKNESS OF METAL MASK : 120 μm

RECOMMENDED THICKNESS OF SOLDER PASTE : 120 μm

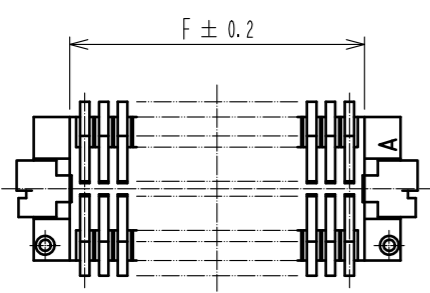
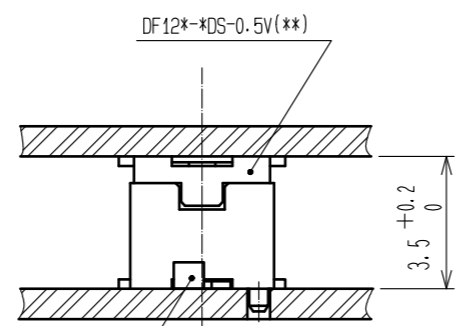
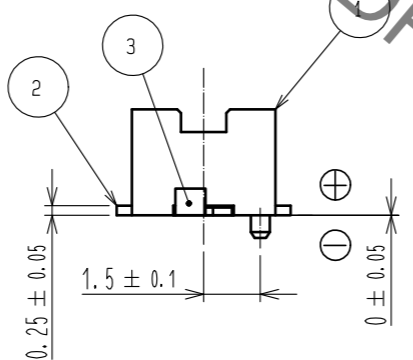
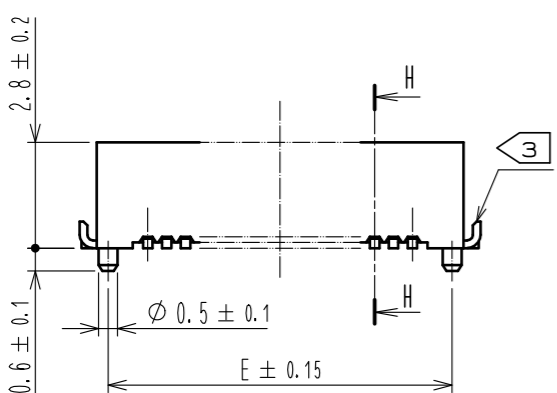

NOTES 1 : LEAD CO-PLANARITY INCLUDING REINFORCED METAL FITTINGS SHALL BE 0.08 mm MAX.

② IF THERE IS PATTERN ON PART, THERE IS A POSSIBILITY THAT IT WILL MAKE CONTACT WITH THE LEADS.

③ REINFORCED METAL FITTINGS AS FOLLOWS.

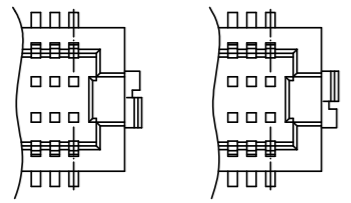

2	PHOSPHOR BRONZE	CONTACT AREA:GOLD PLATED 0.2μm min LEAD AREA:GOLD PLATED 0.015μm MIN OTHERS(UNDER PLATING):NICKEL PLATED 2μm min	7	PS	CLEAR (REINFORCEMENT COLLAR)		
1	POLYAMIDE	UL94V-0, NATURAL (BEIGE)	6	PS	BLACK (PLASTIC REEL)		
			5	POLYESTER	CLEAR (COVER TAPE)		
			4	PS	CLEAR (EMBOSSED CARRIER TAPE)		
			3	BRASS	TIN PLATED 2μm MIN (UNDER PLATING):NICKEL 1μm MIN		
NO.	MATERIAL	FINISH . REMARKS	NO.	MATERIAL	FINISH . REMARKS		
UNITS mm		SCALE 5 : 1	COUNT	DESCRIPTION OF REVISIONS	DESIGNED	CHECKED	DATE
<b>HRS</b> HIROSE ELECTRIC CO., LTD.		APPROVED : WR. FUKUCHI	20190409	DRAWING NO. EDC-163509-86-78			
		CHECKED : WR. FUKUCHI	20190409	PART NO. DF12(3.5)-*DP-0.5V(86)			
		DESIGNED : KT. KUSAKA	20190409	CODE NO. CL537			
		DRAWN : RN. IIDA	20190409				

Jun.1.2020 Copyright 2020 HIROSE ELECTRIC CO., LTD. All Rights Reserved.  
 In case of consideration for using Automotive equipment / device which demand high reliability, kindly contact our sales window correspondents.

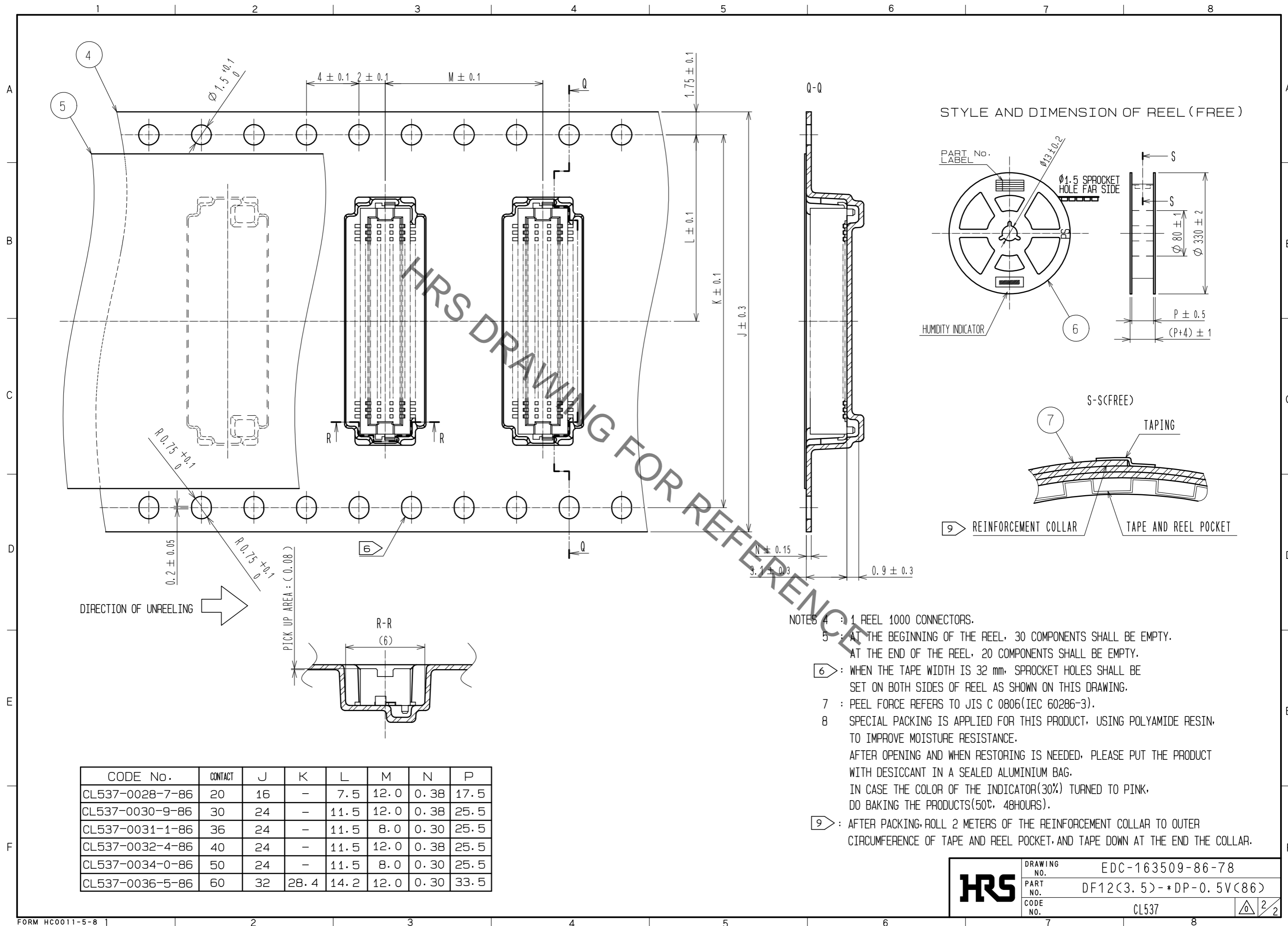

HRS DRAWING FOR REFERENCE

- NOTES
- 4 : 1 REEL 1000 CONNECTORS.
  - 5 : AT THE BEGINNING OF THE REEL, 30 COMPONENTS SHALL BE EMPTY.  
AT THE END OF THE REEL, 20 COMPONENTS SHALL BE EMPTY.
  - 6 : WHEN THE TAPE WIDTH IS 32 mm, SPROCKET HOLES SHALL BE SET ON BOTH SIDES OF REEL AS SHOWN ON THIS DRAWING.
  - 7 : PEEL FORCE REFERS TO JIS C 0806(IEC 60286-3).
  - 8 SPECIAL PACKING IS APPLIED FOR THIS PRODUCT, USING POLYAMIDE RESIN, TO IMPROVE MOISTURE RESISTANCE.  
AFTER OPENING AND WHEN RESTORING IS NEEDED, PLEASE PUT THE PRODUCT WITH DESICCANT IN A SEALED ALUMINIUM BAG.  
IN CASE THE COLOR OF THE INDICATOR(30%) TURNED TO PINK, DO BAKING THE PRODUCTS(50°C, 48HOURS).
  - 9 : AFTER PACKING, ROLL 2 METERS OF THE REINFORCEMENT COLLAR TO OUTER CIRCUMFERENCE OF TAPE AND REEL POCKET, AND TAPE DOWN AT THE END THE COLLAR.

CODE No.	CONTACT	J	K	L	M	N	P
CL537-0028-7-86	20	16	-	7.5	12.0	0.38	17.5
CL537-0030-9-86	30	24	-	11.5	12.0	0.38	25.5
CL537-0031-1-86	36	24	-	11.5	8.0	0.30	25.5
CL537-0032-4-86	40	24	-	11.5	12.0	0.38	25.5
CL537-0034-0-86	50	24	-	11.5	8.0	0.30	25.5
CL537-0036-5-86	60	32	28.4	14.2	12.0	0.30	33.5

HRS	DRAWING NO.	EDC-163509-86-78
	PART NO.	DF12(3.5)-*DP-0.5V(86)
	CODE NO.	CL537
		2/2