

Jun.1.2020 Copyright 2020 HIROSE ELECTRIC CO., LTD. All Rights Reserved.
In case of consideration for using Automotive equipment / device which demand high reliability, kindly contact our sales window correspondents.

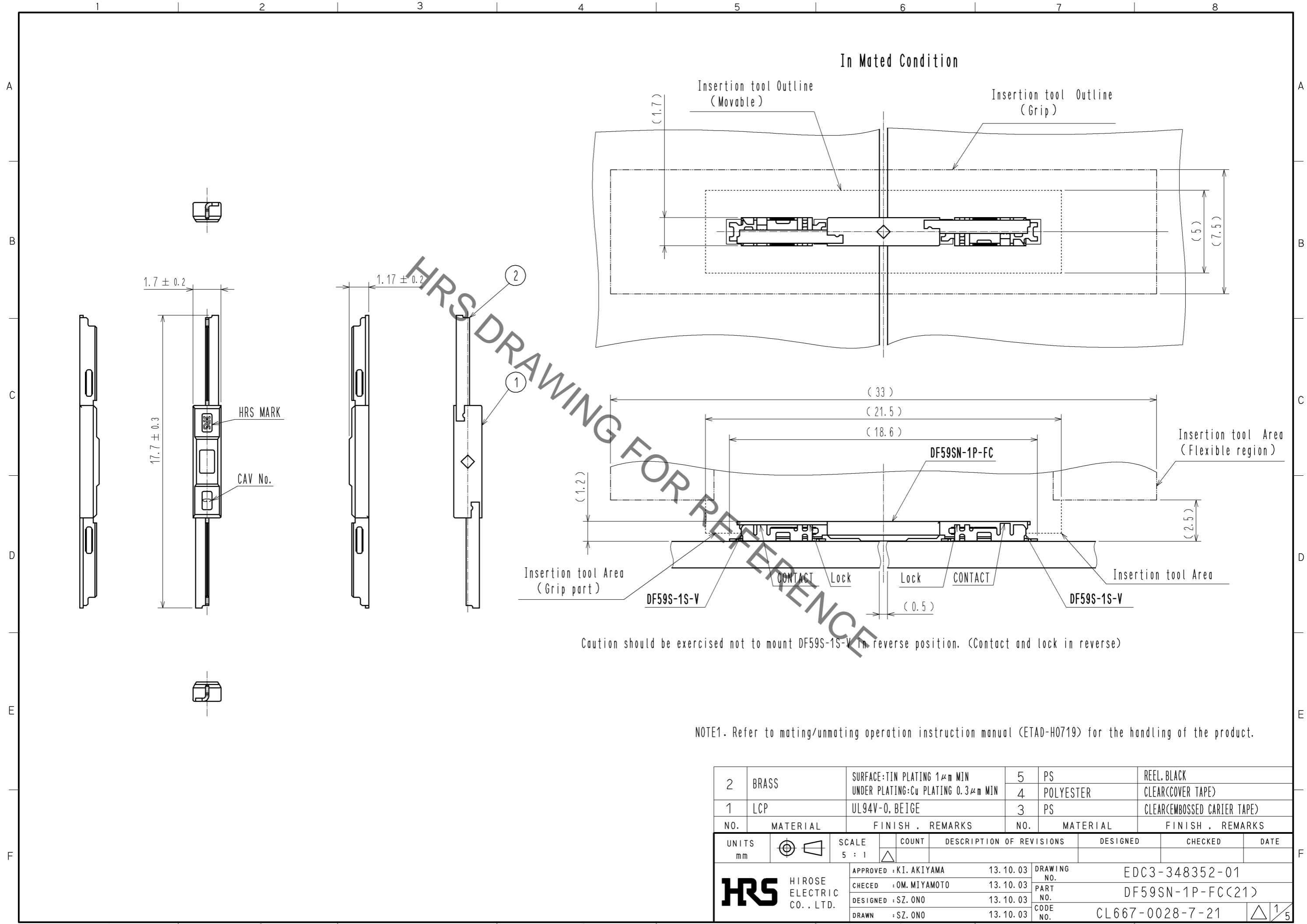

NOTE1. Refer to mating/unmating operation instruction manual (ETAD-H0719) for the handling of the product.

2	BRASS	SURFACE:TIN PLATING 1μm MIN UNDER PLATING:Cu PLATING 0.3μm MIN	5	PS	REEL, BLACK
			4	POLYESTER	CLEAR(COVER TAPE)
1	LCP	UL94V-0, BEIGE	3	PS	CLEAR(EMBOSSED CARRIER TAPE)
NO.	MATERIAL	FINISH . REMARKS	NO.	MATERIAL	FINISH . REMARKS
UNITS mm		SCALE 5 : 1	COUNT 	DESCRIPTION OF REVISIONS	
APPROVED : KI. AKIYAMA 13.10.03			DESIGNED	CHECKED	
CHECED : OM. MIYAMOTO 13.10.03			DATE	DATE	
DESIGNED : SZ. ONO 13.10.03			DRAWING NO. EDC3-348352-01		
DRAWN : SZ. ONO 13.10.03			PART NO. DF59SN-1P-FC(21)		
HRS HIROSE ELECTRIC CO., LTD.			CODE NO. CL667-0028-7-21		
			DATE 13.10.03		

Jun.1.2020 Copyright 2020 HIROSE ELECTRIC CO., LTD. All Rights Reserved.
 In case of consideration for using Automotive equipment / device which demand high reliability, kindly contact our sales window correspondents.

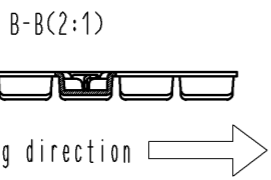
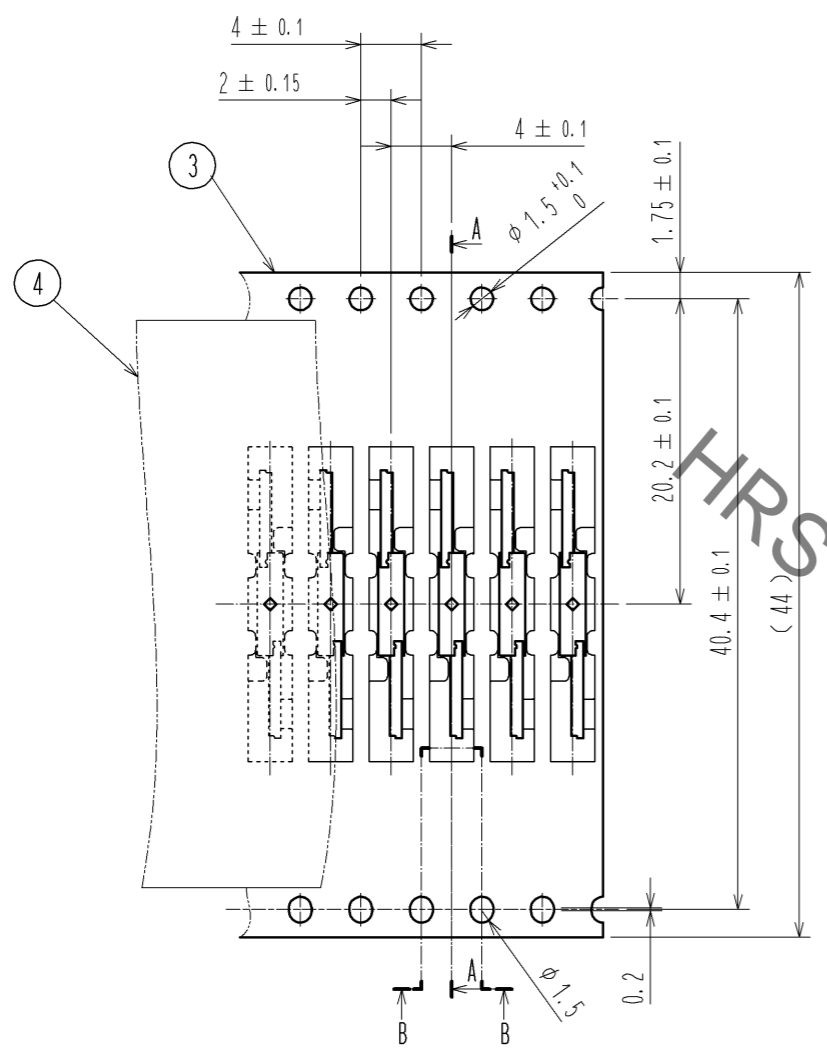

A-A(2:1)

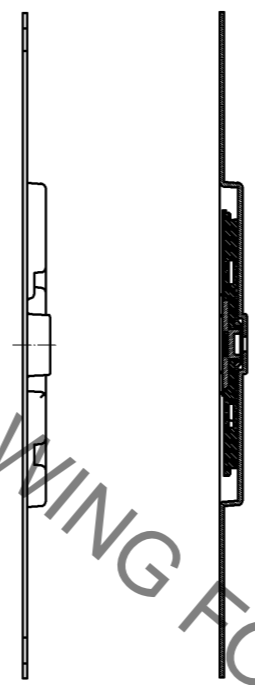

Reel style and Dimensions (Free)

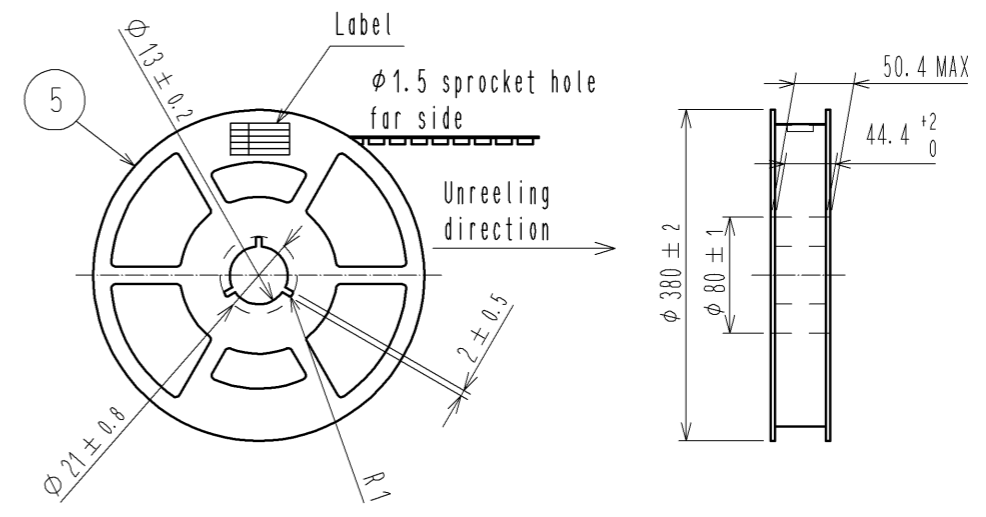

Detail of Part no. Label

生産月日	年 月 日
図 番	CL667-0028-7-21
品 名	DF59SN-1P-FC(21)
納入数量	10000 KO
納入者	ヒロセ電機(株)

Taping(Free)

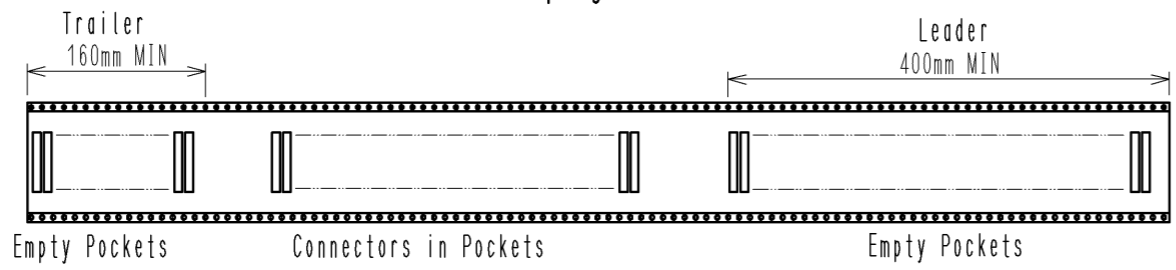

NOTE2. 1Reel:10000 Connectors.
 3. The dimensions in parentheses are for reference.

HRS	DRAWING NO.	EDC3-348352-01
	PART NO.	DF59SN-1P-FC(21)
	CODE NO.	CL667-0028-7-21
		△ 2/5

DF59S Operation Procedures for Floating Socket

《Mating》

<How to pick up the socket>

Pick up the socket from a reel pocket with the insertion tool (DF59SN-1P-FC/IN-TOOL).

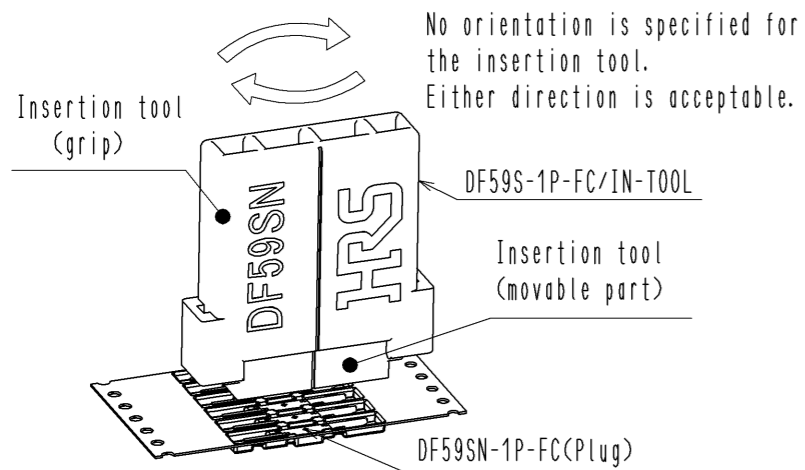

1. Align the insertion tool to the pocket by using positioning guides.

2. Press down the insertion tool to the socket in the pocket vertically and lift it up, then the socket is captured into the insertion tool.

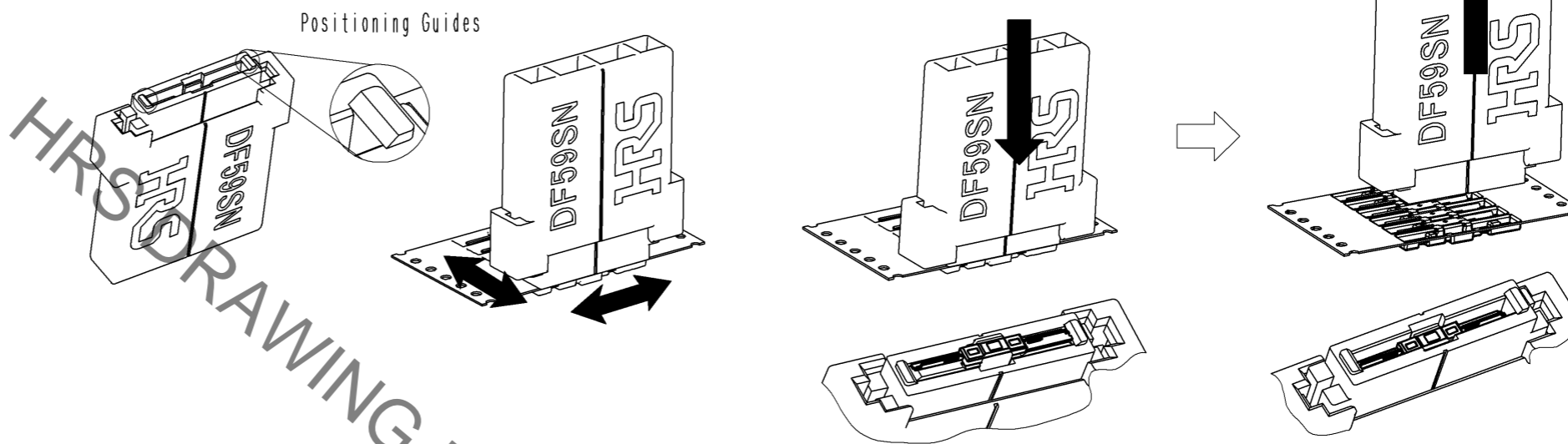

<How to mate the socket to the receptacle>

Mate the socket captured by the insertion tool to the receptacles.

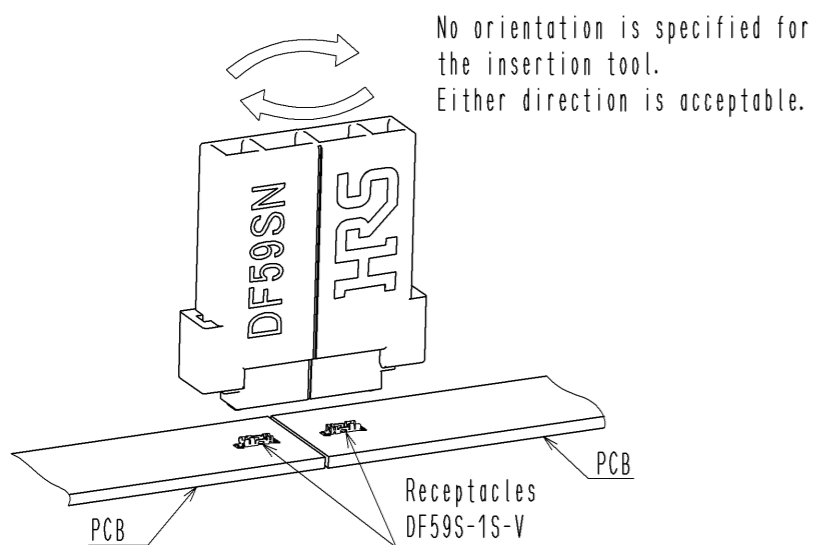

3. Align the insertion tool to receptacles by using positioning guides.

※Align the center line of insertion tool to the center between PCBs.

4. Press straight down the insertion tool to the receptacles (PCBs), and lift it up.

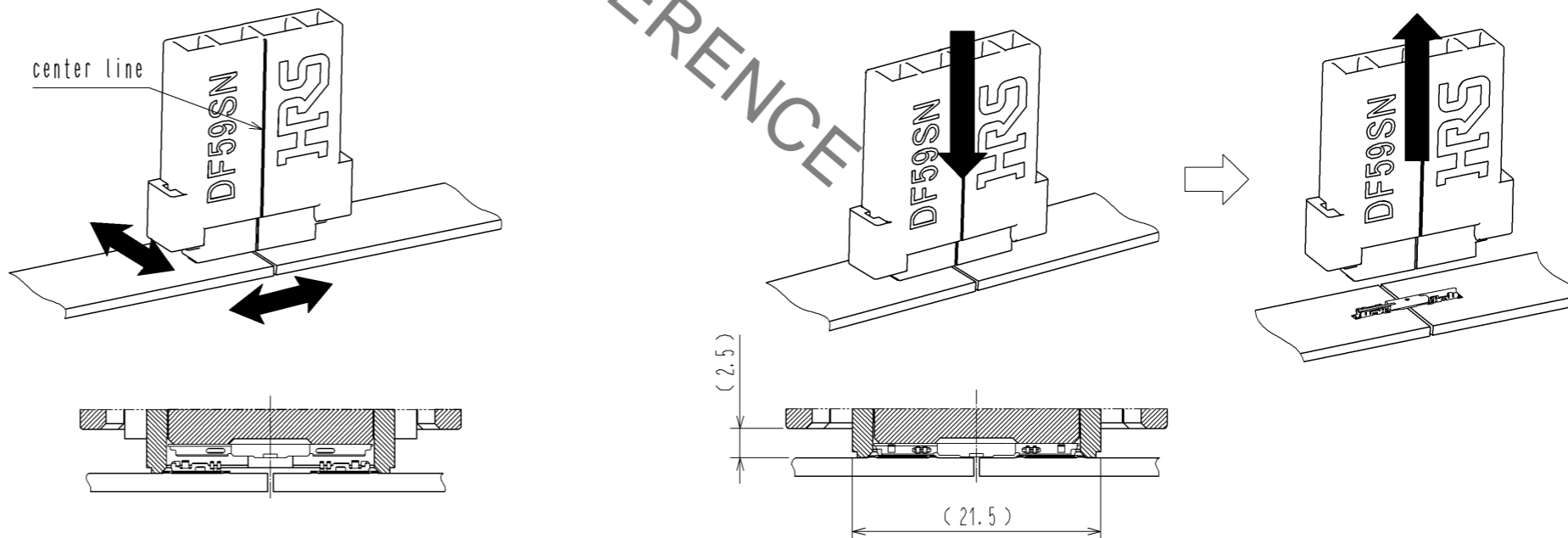

HRS	DRAWING NO.	EDC3-348352-01
	PART NO.	DF59SN-1P-FC(21)
	CODE NO.	CL667-0028-7-21
		△ 3/5

Jun.1.2020 Copyright 2020 HIROSE ELECTRIC CO., LTD. All Rights Reserved. In case of consideration for using Automotive equipment / device which demand high reliability, kindly contact our sales window correspondents.

Jun.1.2020 Copyright 2020 HIROSE ELECTRIC CO., LTD. All Rights Reserved.
In case of consideration for using Automotive equipment / device which demand high reliability, kindly contact our sales window correspondents.

《Unmating》

1. Hook the lever on either sides of floating socket with finger and lift up to the upper direction for unlock.
(Lift up until friction lock is released.)

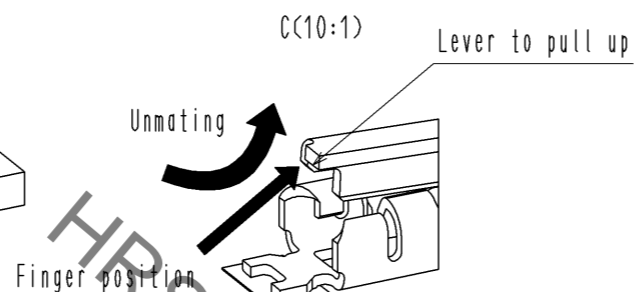
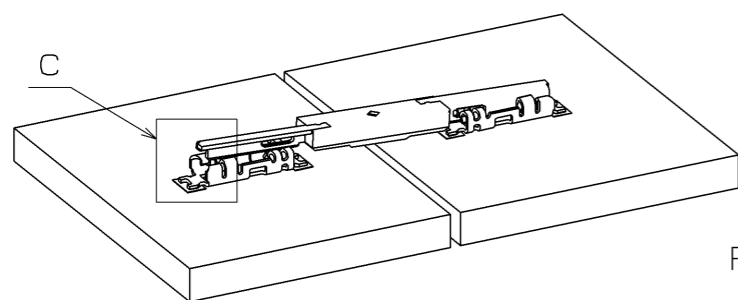

2. After releasing either side, hook the lever on the other side with a finger and lift up to the upper direction, too.

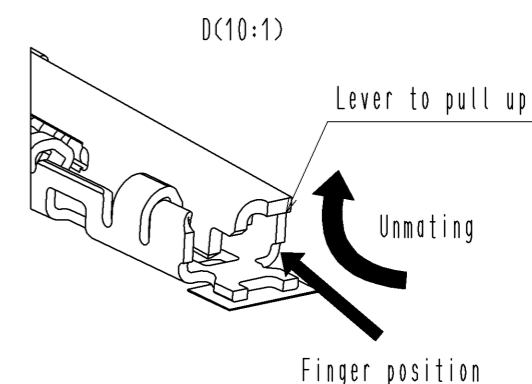
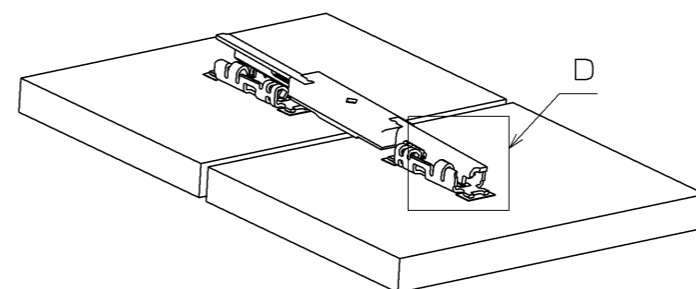

Withdrawal tool is also available, and its operation is the same as in case of using finger.

1. Hook the lever on either sides of the socket with the hook portion of the withdrawal tool, and lift it up straight to the upper direction for unlock.
(Lift up until friction lock is released.)

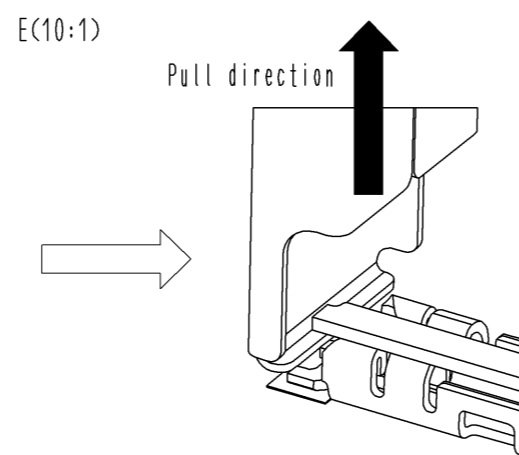
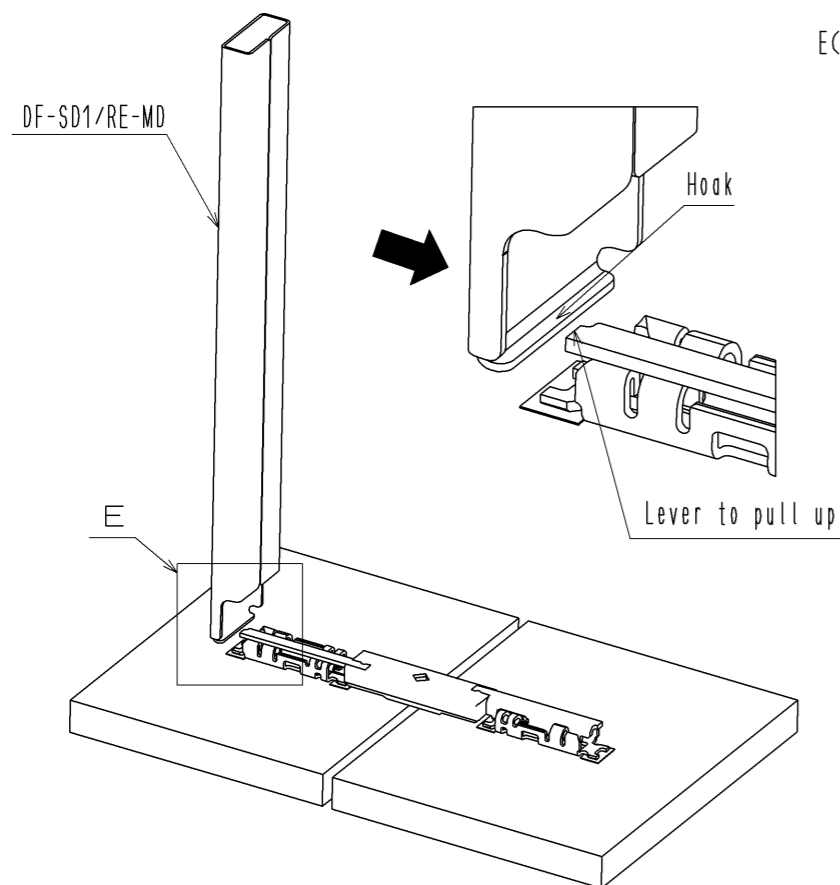

2. After releasing either side, hook the lever on the other side with the withdrawal tool and lift up to the upper direction, too.

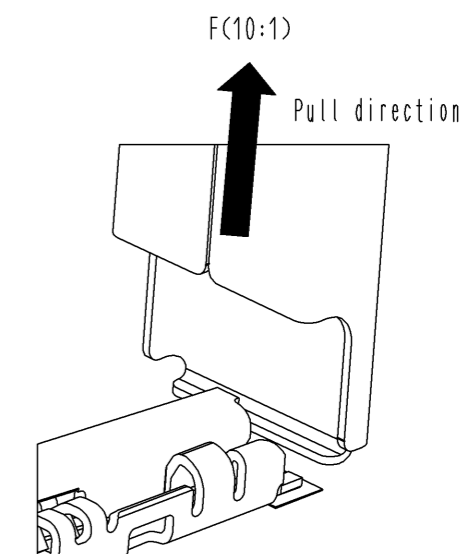
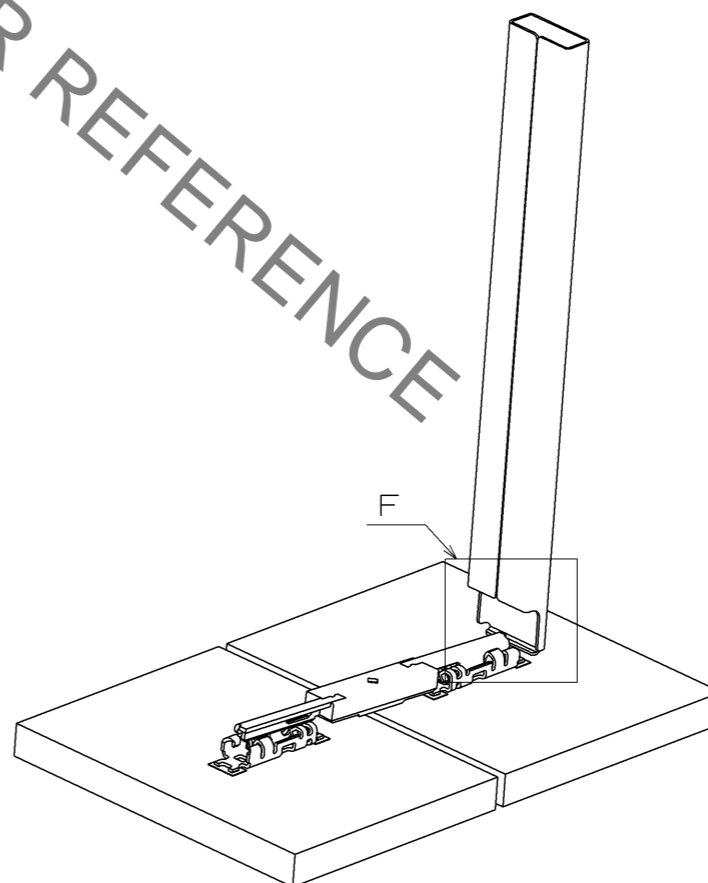

HRS DRAWING FOR REFERENCE

HRS	DRAWING NO.	EDC3-348352-01
	PART NO.	DF59SN-1P-FC(21)
	CODE NO.	CL667-0028-7-21
		△ 4/5

Jun.1.2020 Copyright 2020 HIROSE ELECTRIC CO., LTD. All Rights Reserved.
In case of consideration for using Automotive equipment / device which demand high reliability, kindly contact our sales window correspondents.

Floating Range of DF59SN

Follow the specified floating range as shown below.

«Direction of X axis»

Floating range in X direction

■ Floating in X direction : +0.5mm

■ Standard Position

■ Direction of X axis floating : -0.5mm

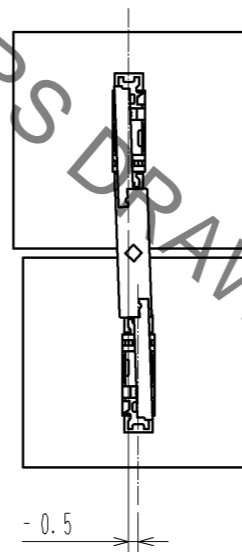
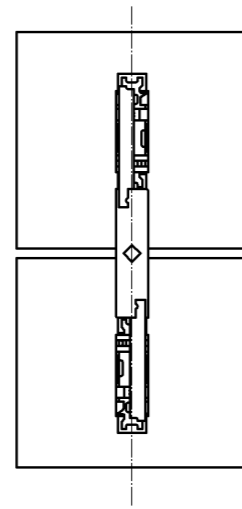
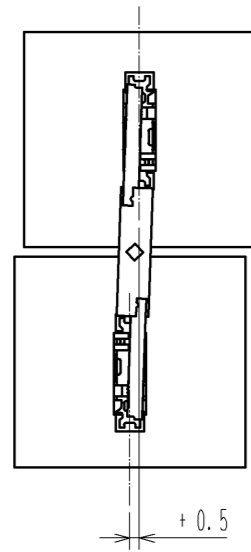

«Direction of Y axis»

Floating range in Y direction

■ Floating in Y direction : +0.5mm

■ Standard Position

■ Direction of Y axis floating : -0.5mm

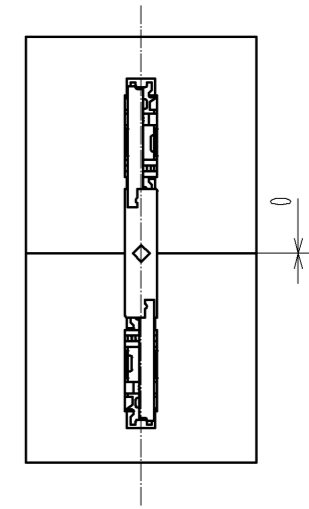
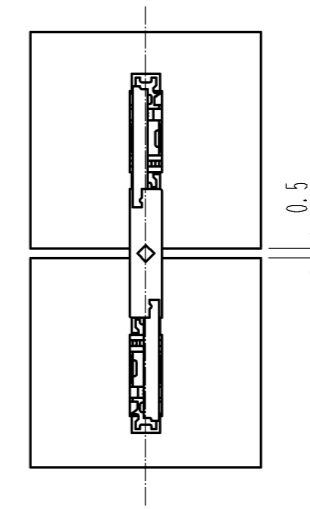
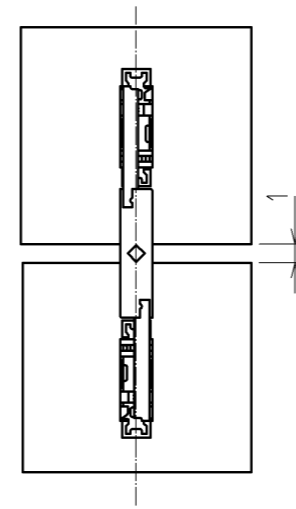

«Direction of Z axis»

Floating range in Z direction

■ Floating in Z direction : +0.2mm

■ Standard Position

■ Direction of Z axis floating : -0.2mm

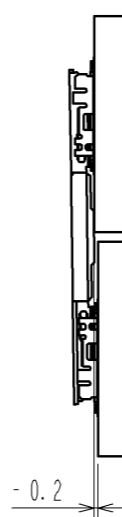
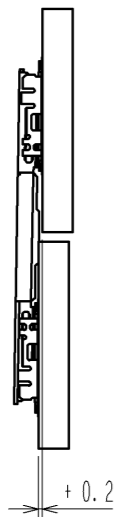

HRS DRAWING FOR REFERENCE

HRS	DRAWING NO.	EDC3-348352-01
	PART NO.	DF59SN-1P-FC(21)
	CODE NO.	CL667-0028-7-21
		△ 5/5