

Jun.1.2020 Copyright 2020 HIROSE ELECTRIC CO., LTD. All Rights Reserved.
 In case of consideration for using Automotive equipment / device which demand high reliability, kindly contact our sales window correspondents.

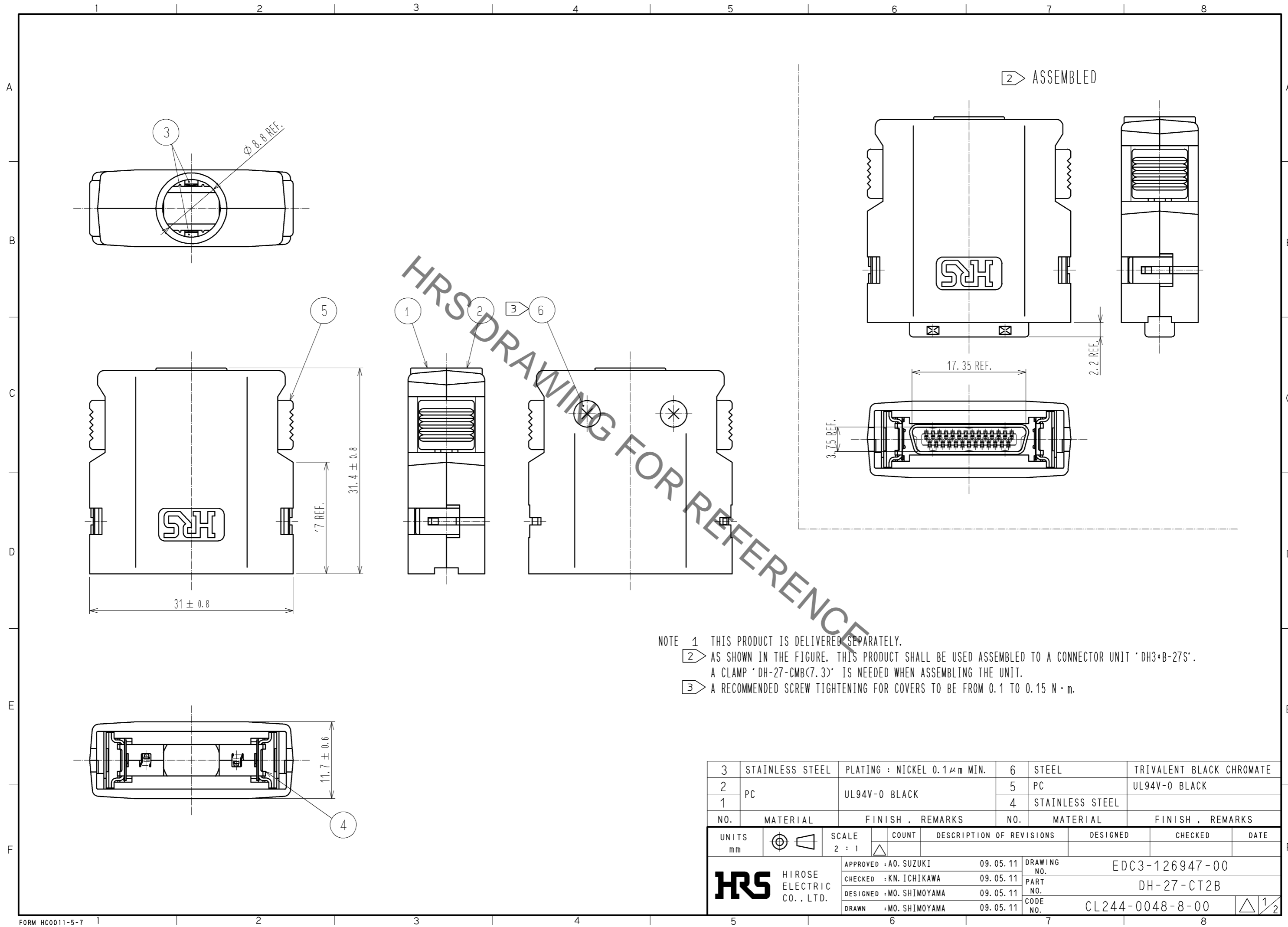

NOTE 1 THIS PRODUCT IS DELIVERED SEPARATELY.
 2 AS SHOWN IN THE FIGURE, THIS PRODUCT SHALL BE USED ASSEMBLED TO A CONNECTOR UNIT 'DH3+B-27S'.
 A CLAMP 'DH-27-CMB(7.3)' IS NEEDED WHEN ASSEMBLING THE UNIT.
 3 A RECOMMENDED SCREW TIGHTENING FOR COVERS TO BE FROM 0.1 TO 0.15 N · m.

3	STAINLESS STEEL	PLATING : NICKEL 0.1 μm MIN.	6	STEEL	TRIVALENT BLACK CHROMATE			
2	PC	UL94V-0 BLACK	5	PC	UL94V-0 BLACK			
1			4	STAINLESS STEEL				
NO.	MATERIAL	FINISH . REMARKS	NO.	MATERIAL	FINISH . REMARKS			
UNITS	mm	SCALE	2 : 1	COUNT	DESCRIPTION OF REVISIONS	DESIGNED	CHECKED	DATE
HIROSE ELECTRIC CO., LTD.		APPROVED	: A0. SUZUKI	09. 05. 11	DRAWING NO. EDC3-126947-00			
		CHECKED	: KN. ICHIKAWA	09. 05. 11	PART NO. DH-27-CT2B			
		DESIGNED	: MO. SHIMOYAMA	09. 05. 11	CODE NO. CL244-0048-8-00			
		DRAWN	: MO. SHIMOYAMA	09. 05. 11	1/2			

Jun.1.2020 Copyright 2020 HIROSE ELECTRIC CO., LTD. All Rights Reserved.
In case of consideration for using Automotive equipment / device which demand high reliability, kindly contact our sales window correspondents.

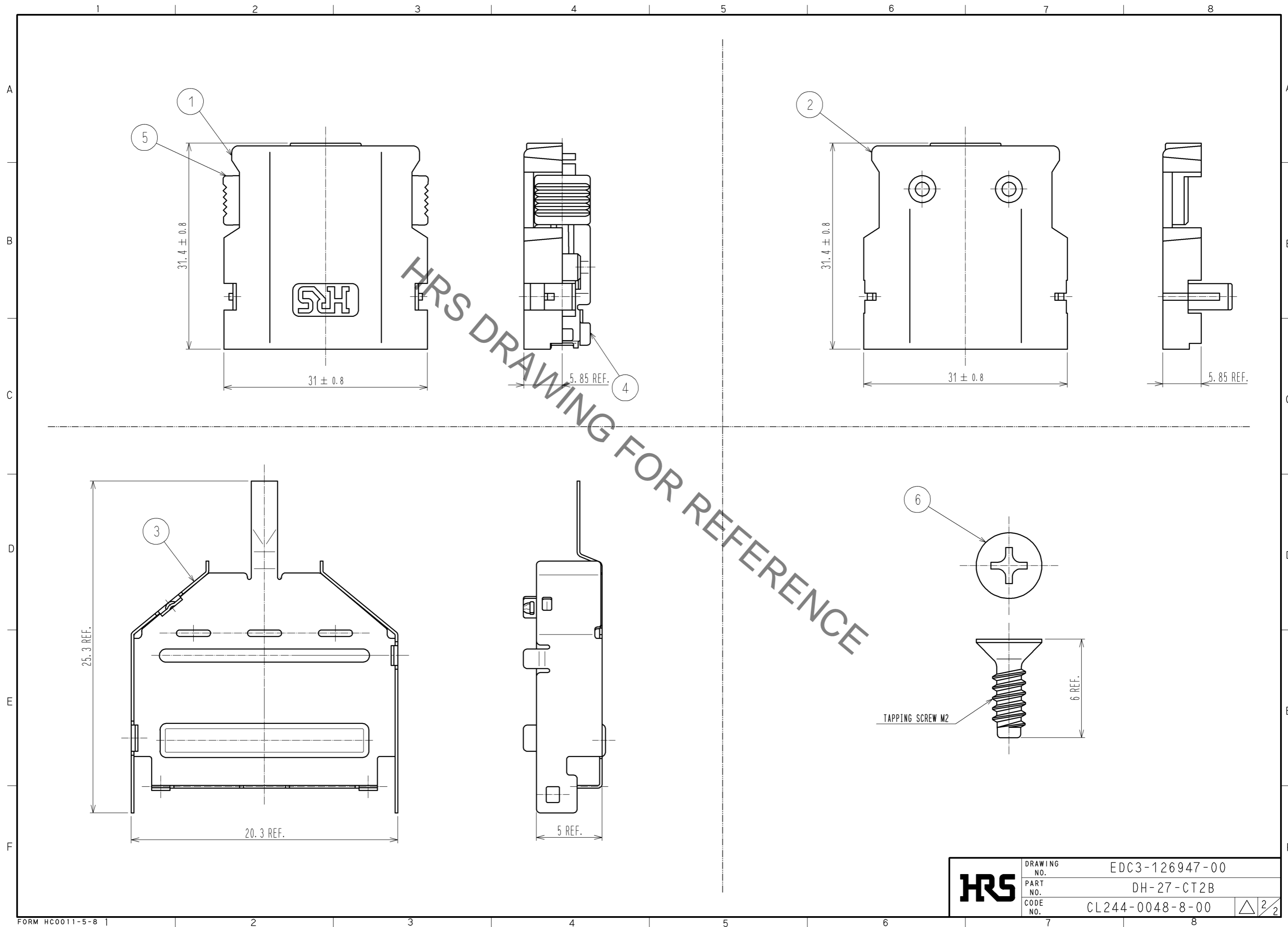

HRS	DRAWING NO.	EDC3-126947-00
	PART NO.	DH-27-CT2B
	CODE NO.	CL244-0048-8-00
		\triangle 2/2