

Jun.1.2020 Copyright 2020 HIROSE ELECTRIC CO., LTD. All Rights Reserved.
In case of consideration for using Automotive equipment / device which demand high reliability, kindly contact our sales window correspondents.

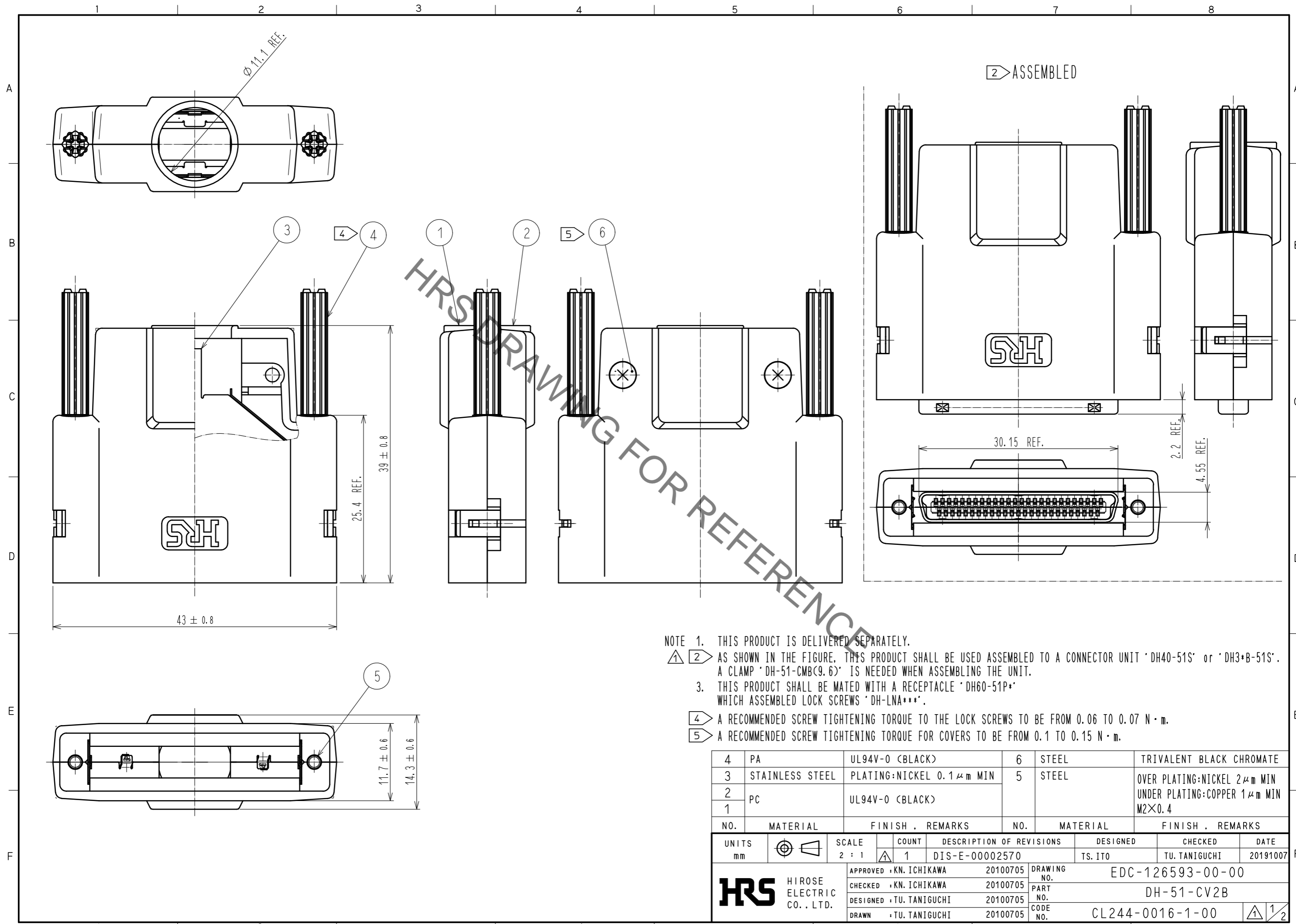

- NOTE 1. THIS PRODUCT IS DELIVERED SEPARATELY.
 2 AS SHOWN IN THE FIGURE, THIS PRODUCT SHALL BE USED ASSEMBLED TO A CONNECTOR UNIT 'DH40-51S' or 'DH3*B-51S'. A CLAMP 'DH-51-CMB(9.6)' IS NEEDED WHEN ASSEMBLING THE UNIT.
 3. THIS PRODUCT SHALL BE MATED WITH A RECEPTACLE 'DH60-51P*' WHICH ASSEMBLED LOCK SCREWS 'DH-LNA***'.
 4 A RECOMMENDED SCREW TIGHTENING TORQUE TO THE LOCK SCREWS TO BE FROM 0.06 TO 0.07 N · m.
 5 A RECOMMENDED SCREW TIGHTENING TORQUE FOR COVERS TO BE FROM 0.1 TO 0.15 N · m.

NO.	MATERIAL	FINISH . REMARKS	NO.	MATERIAL	FINISH . REMARKS
4	PA	UL94V-0 (BLACK)	6	STEEL	TRIVALENT BLACK CHROMATE
3	STAINLESS STEEL	PLATING:NICKEL 0.1 μm MIN	5	STEEL	OVER PLATING:NICKEL 2 μm MIN UNDER PLATING:COPPER 1 μm MIN
2	PC	UL94V-0 (BLACK)			M2×0.4
1					

UNITS	SCALE	COUNT	DESCRIPTION OF REVISIONS	DESIGNED	CHECKED	DATE
mm	2 : 1	1	DIS-E-00002570	TS. ITO	TU. TANIGUCHI	20191007
APPROVED : KN. ICHIKAWA			20100705	DRAWING NO. EDC-126593-00-00		
CHECKED : KN. ICHIKAWA			20100705	PART NO. DH-51-CV2B		
DESIGNED : TU. TANIGUCHI			20100705	CODE NO. CL244-0016-1-00		
DRAWN : TU. TANIGUCHI			20100705	1/2		

Jun.1.2020 Copyright 2020 HIROSE ELECTRIC CO., LTD. All Rights Reserved.
 In case of consideration for using Automotive equipment / device which demand high reliability, kindly contact our sales window correspondents.

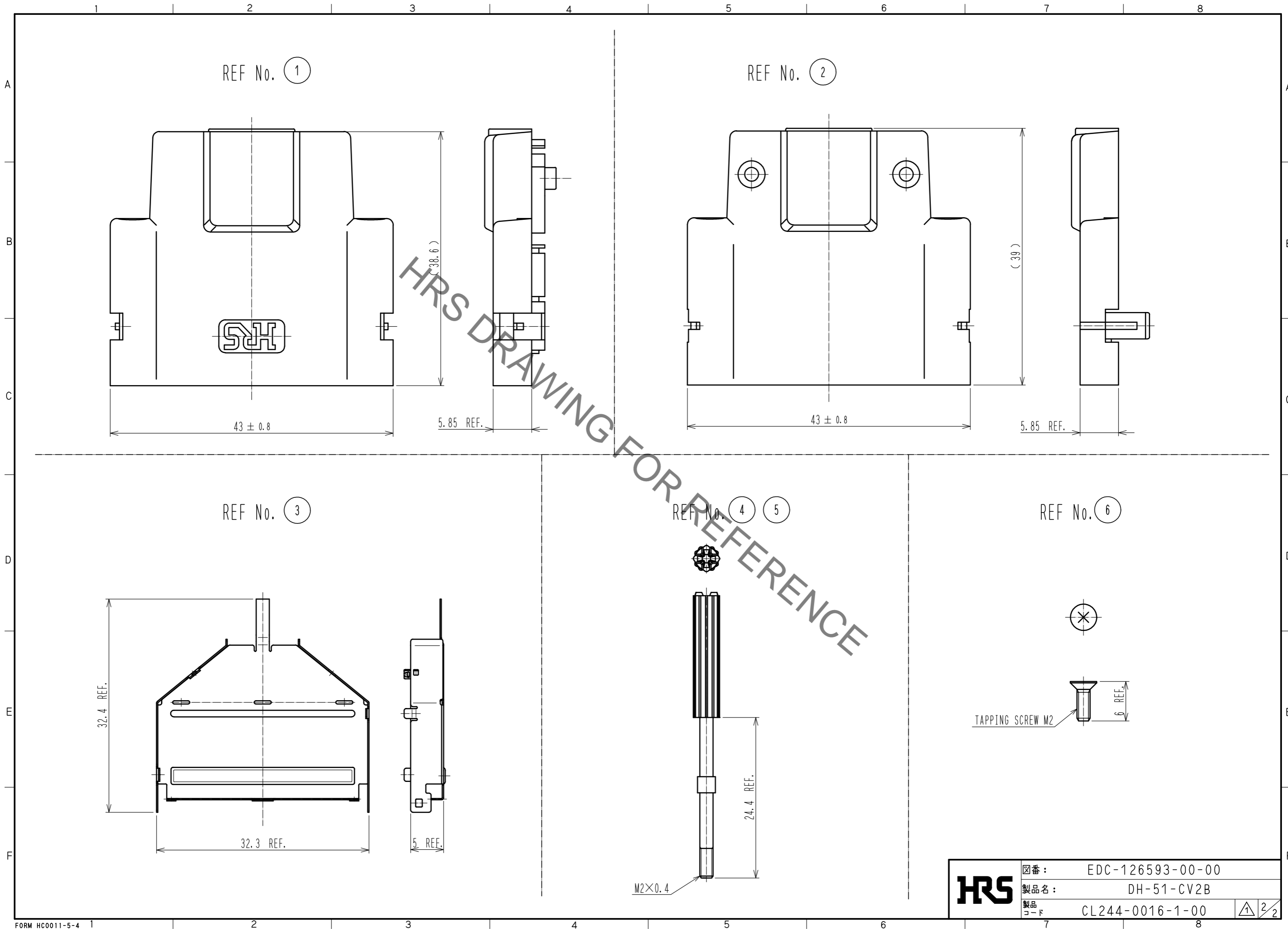

HRS	図番:	EDC-126593-00-00	2/2
	製品名:	DH-51-CV2B	
	製品コード:	CL244-0016-1-00	