

Jun.1.2020 Copyright 2020 HIROSE ELECTRIC CO., LTD. All Rights Reserved.  
 In case of consideration for using Automotive equipment / device which demand high reliability, kindly contact our sales window correspondents.

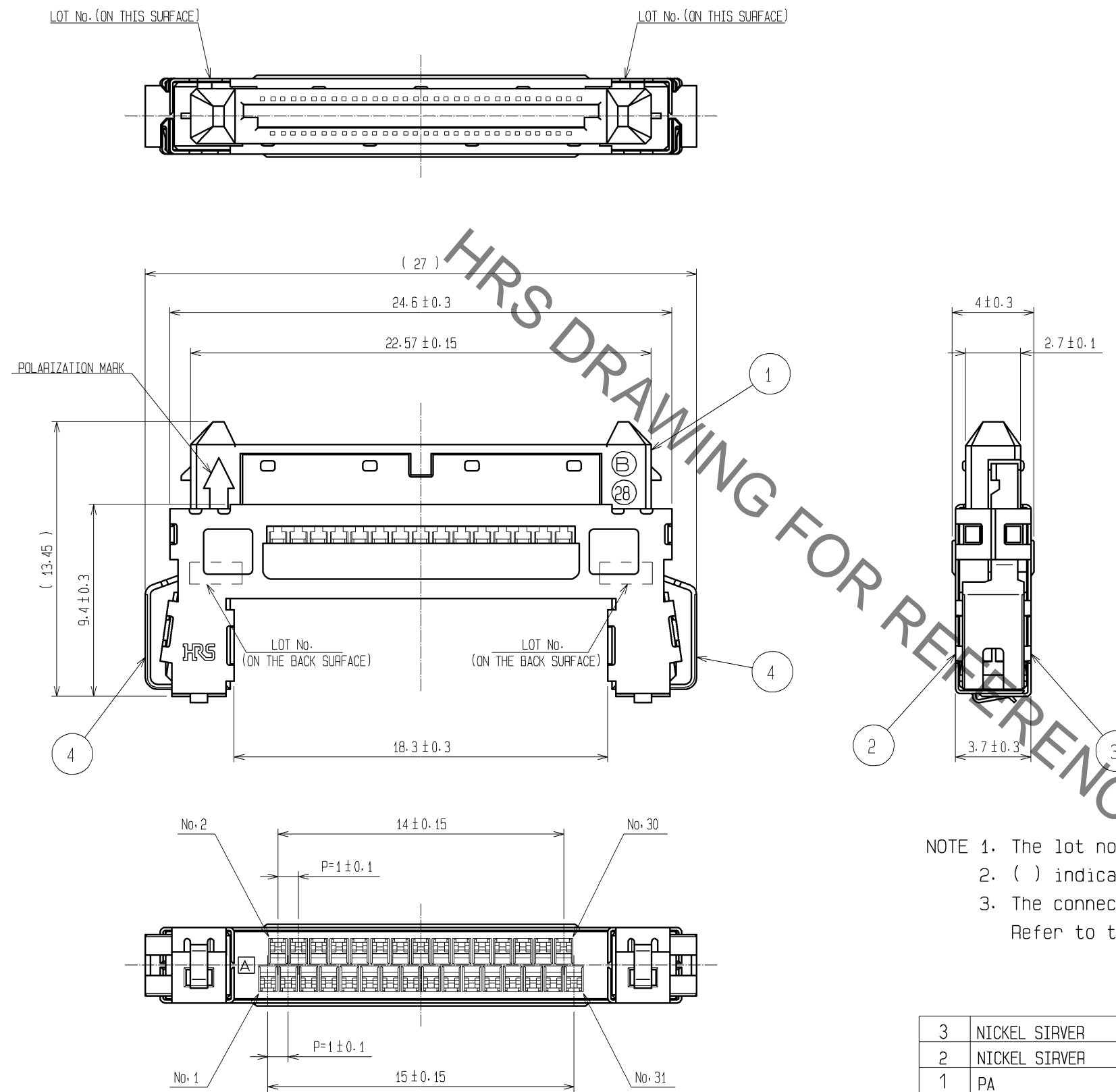

HRS DRAWING FOR REFERENCE

NOTE 1. The lot no. is marked on right and left areas of the indicated surface.  
 2. ( ) indicates a reference dimension.  
 3. The connectors are delivered in tray packaging.  
 Refer to the package specification drawing on Sheet 2 for details.

3	NICKEL SIRVER							
2	NICKEL SIRVER		5	PS	TRAY			
1	PA	BLACK	UL94V-0	4	STAINLESS			
NO.	MATERIAL	FINISH	REMARKS	NO.	MATERIAL	FINISH	REMARKS	
UNITS		SCALE	COUNT	DESCRIPTION OF REVISIONS		DESIGNED	CHECKED	DATE
mm		4 : 1						
<b>HRS</b>		HIROSE ELECTRIC CO., LTD.		APPROVED : HS. OKAWA	08.09.11	DRAWING NO. EDC3-156431-00		
				CHECKED : HT. YAMAGUCHI	08.09.11	PART NO. FX15SW-31P-C		
				DESIGNED : KN. SHIBUYA	08.09.10	CODE NO. CL575-2113-1-00		
				DRAWN : TH. SANO	08.09.10			1/4

Jun.1.2020 Copyright 2020 HIROSE ELECTRIC CO., LTD. All Rights Reserved.  
In case of consideration for using Automotive equipment / device which demand high reliability, kindly contact our sales window correspondents.

# DRAWING FOR PACKING (1:2)

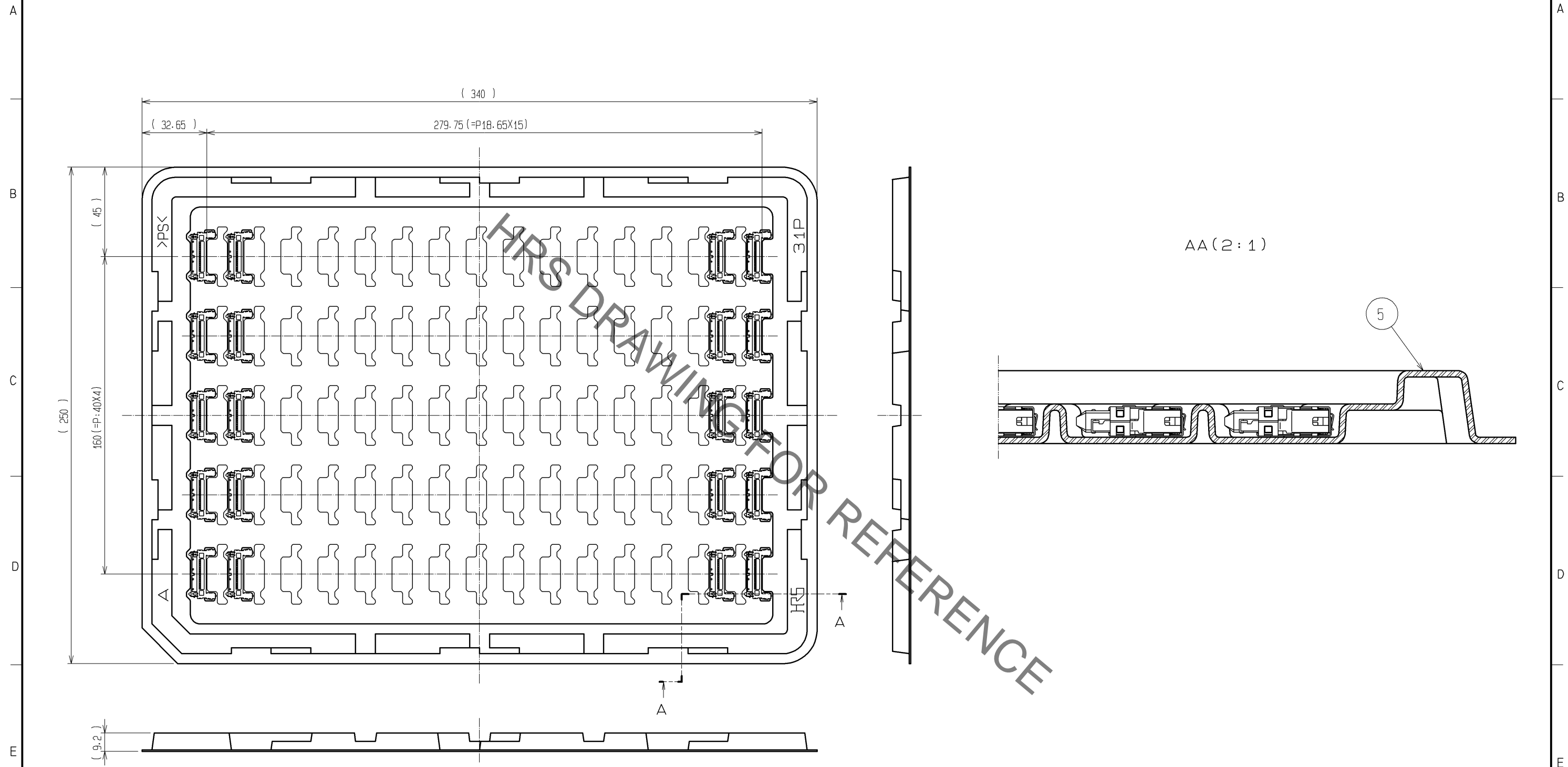

- NOTE 1. One tray contains 80 connectors.  
2. Connectors are arranged in tray packaging as shown in the figure.  
However, either connector surface can be the top.  
3. ( ) indicates a reference dimension.

<b>HRS</b>	DRAWING NO.	EDC3-156431-00
	PART NO.	FX15SW-31P-C
	CODE NO.	CL575-2113-1-00
		△ 2/4

Jun.1.2020 Copyright 2020 HIROSE ELECTRIC CO., LTD. All Rights Reserved.  
In case of consideration for using Automotive equipment / device which demand high reliability, kindly contact our sales window correspondents.

This connector requires careful handling. Please operate the connector with understanding of the following operation instructions.

**Cautions for cable assembly**

◆ Cable assembly conditions

It is recommended that prior to starting of the cable termination the following information be obtained from Hirose. All documents may be requested from the nearest Hirose sales office or agency.

1. Crimping operation basic instruction (Basic information about cable assembly)
2. Instruction Manual-Contact crimp termination (Description of the press)
3. Installation Table-Applicator parts (Installation instruction-Applicator)
4. Table of crimp conditions (Crimp height, Tensile strength)
5. Manual of Crimp Quality Standards (Bell-mouth dimensions, Bend up/down, Rolling, others)

Follow the instructions in the documents for proper cable assembly.

◆ Crimped contact insertion

Insert the crimped contacts straight, aligning the faces of the housing lance and the metal latch as shown in the figure. Insertion will not be completed without the alignment. It may also cause the deformation of the crimped contacts or the damage to the housing.

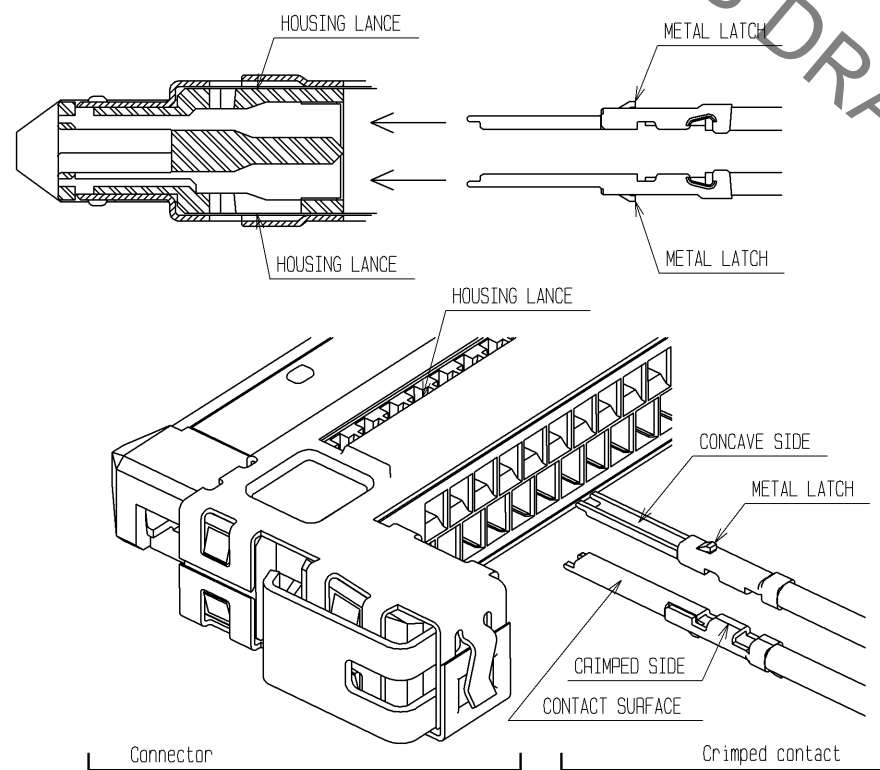

◆ Insertion confirmation of crimped contact

To confirm the proper contact insertion, check the position of the metal latch through the housing lance opening. With the contact properly inserted, the metal latch is positioned where it has completely passed through the housing lance.

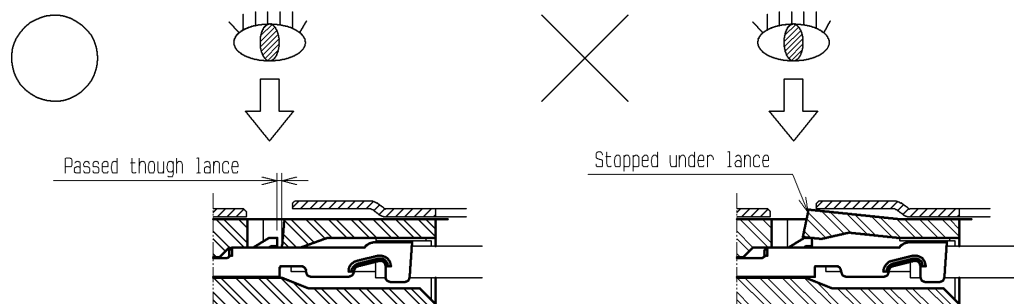

When the cable needs to be pulled for the check, make sure that the applied force is 3 N or lower. Excessive pulling of the cable may damage the housing lance, resulting in the deterioration of the lance retention force.

◆ Repair of crimped contacts

To extract the crimped contact after insertion, pull the cable, with lifting the housing lance with a pointy tool such as a needle. The repair work may have reduced the lance retention force. Therefore, do not reuse the repaired connector. Prepare a new connector.

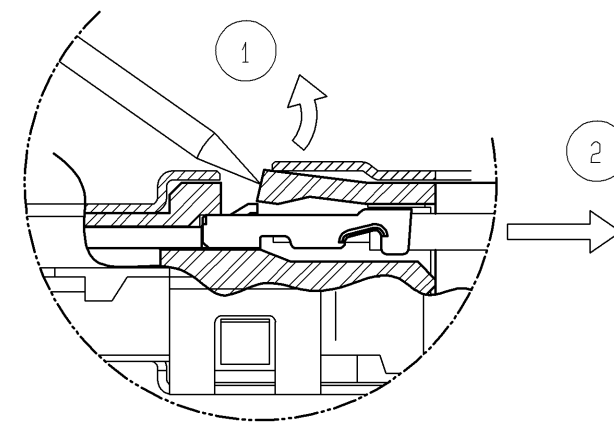

**Cautions for mating with on-board connector**

◆ Insertion to on-board connector

The connector mating is keyed. Align the marks as shown in the figure for mating. Insert the connector completely until they are locked at both ends. The connectors have a reverse-insertion prevention structure, however, the connectors may be damaged when inserted reversely with the force of 25 N or more. Avoid a forceful insertion, and make sure to confirm that the connectors are aligned with the marks before the mating operation.

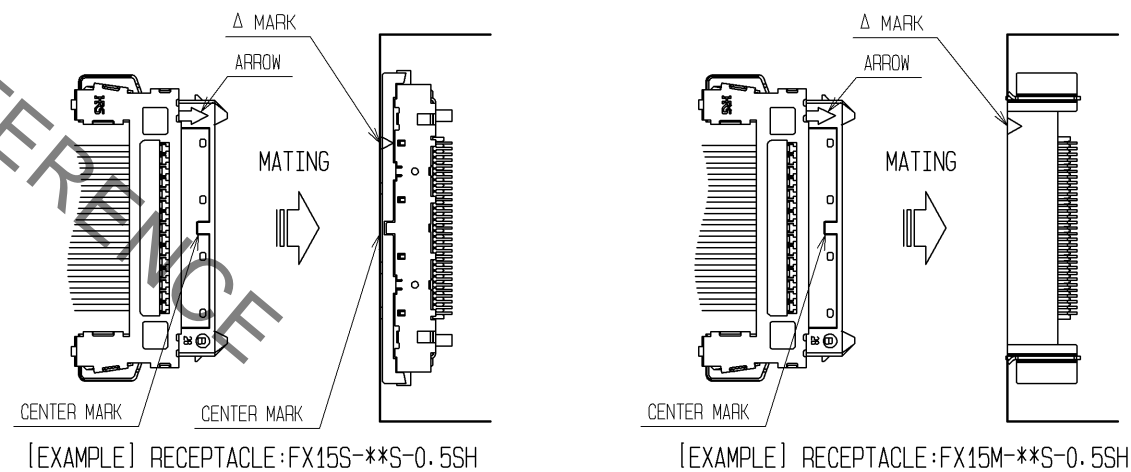

Note: The connectors shown in this "INSTRUCTION MANUAL" are drawn for the instruction purpose, therefore, the appearance differs from the actual connectors. Please confirm the connector configuration on the connector drawing (SHEET 1).

INSTRUCTION MANUAL

<b>HRS</b>	DRAWING NO.	EDC3-156431-00
	PART NO.	FX15SW-31P-C
	CODE NO.	CL575-2113-1-00
		△ 3/4

Jun.1.2020 Copyright 2020 HIROSE ELECTRIC CO., LTD. All Rights Reserved.  
In case of consideration for using Automotive equipment / device which demand high reliability, kindly contact our sales window correspondents.

◆ After mating

Carefully wire cables, so that excessive force will not be applied to the mated connectors. Especially, pulling a single cable with the force of 5 N or more may cause the cable (crimped contact) to fall out. Also, pulling a whole set of cables with the force of 20 N or more may damage the connectors. Take a caution to avoid pulling the cables.

◆ Withdrawal from on-board connector

The connectors are locked while they are mated. In order to unmate the connectors, pull the connector straight, with releasing the lock by pushing both sides of the connector. At this time, do not pull the cable. Also, avoid the withdrawal in angle, which may damage the connectors.

<Proper withdrawal>

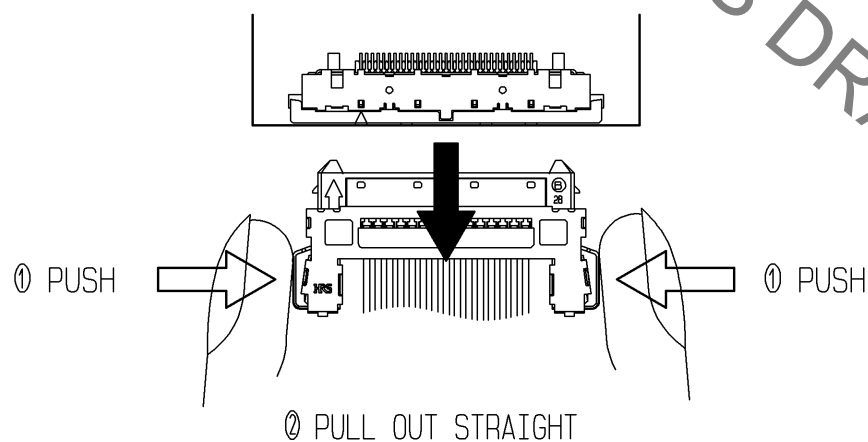

<Improper withdrawal>

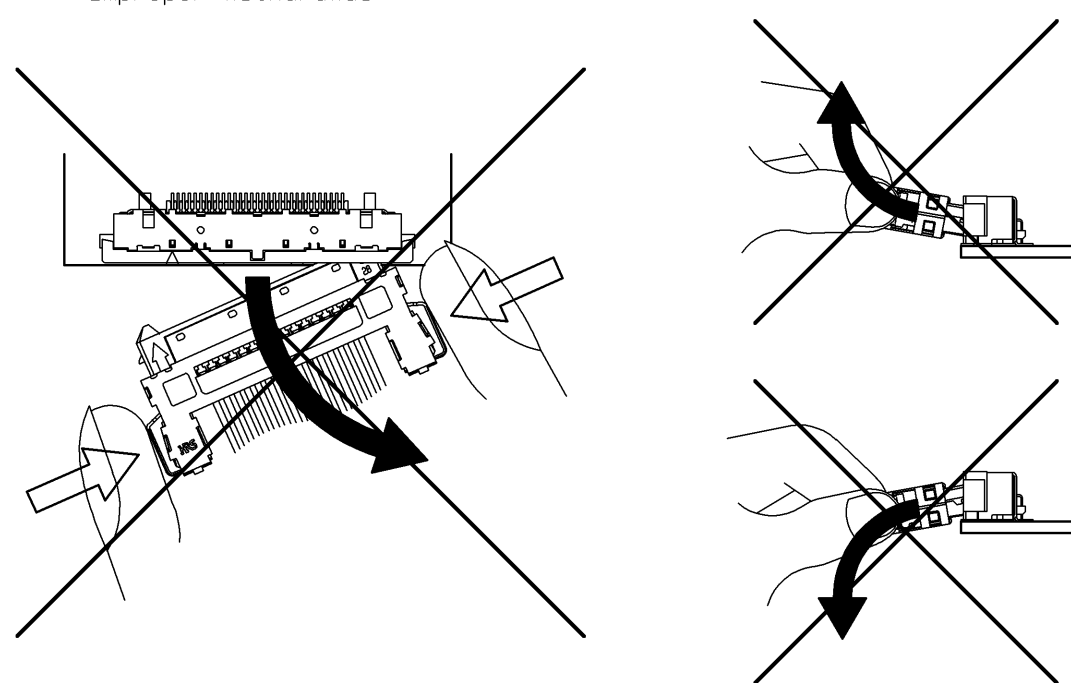

Cautions for soldering

◆ Grounding method of cable shield

The cable shield and ground wire can be connected to the connector by soldering. Make sure to solder properly, following the cautions below.

1. Solder the wire to the connector at the recommended area.  
Note that the soldering out of the recommended area may effect the product performance.
2. Follow the temperature of the soldering tip and the time of soldering specified in the product specification sheet.
3. Avoid applying excessive stress to the connector during soldering with the soldering tip.
4. Take a caution for the flux desertion from wire soldering.  
The flux attached at the contact area may cause a contact failure.

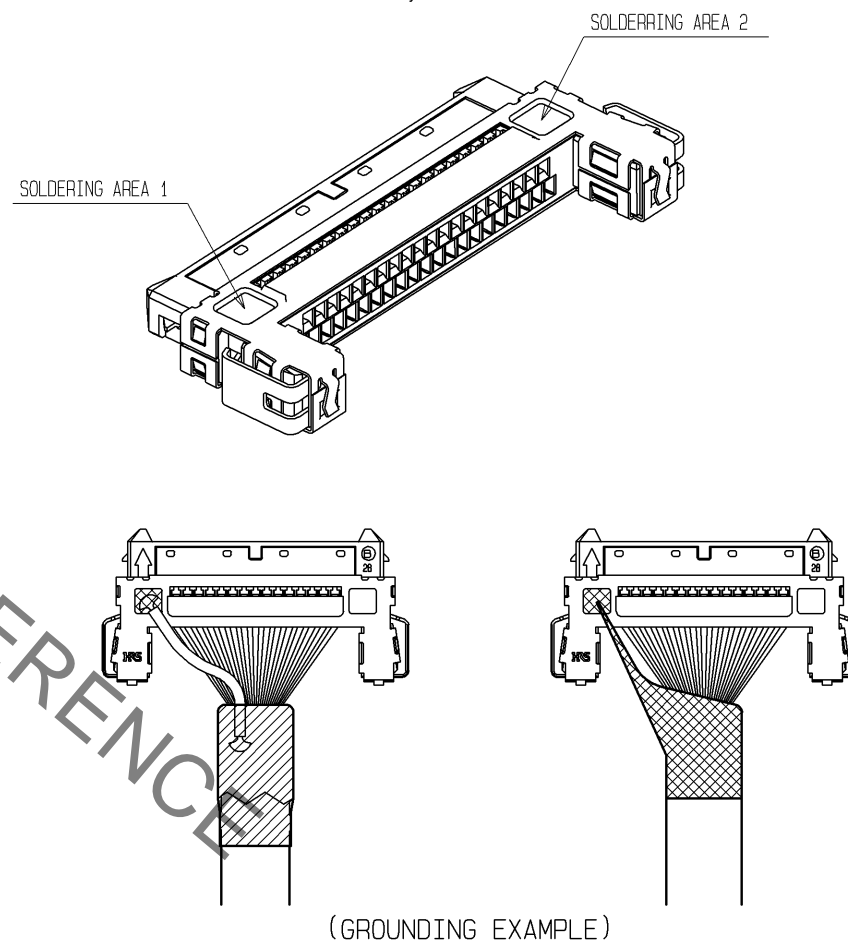

Note: The connectors shown in this "INSTRUCTION MANUAL" are drawn for the instruction purpose, therefore, the appearance differs from the actual connectors. Please confirm the connector configuration on the connector drawing (SHEET 1).

INSTRUCTION MANUAL

<b>HRS</b>	DRAWING NO.	EDC3-156431-00
	PART NO.	FX15SW-31P-C
	CODE NO.	CL575-2113-1-00
		△ 4/4