

Jun.1.2020 Copyright 2020 HIROSE ELECTRIC CO., LTD. All Rights Reserved.
In case of consideration for using Automotive equipment / device which demand high reliability, kindly contact our sales window correspondents.

COUNT	DESCRIPTION OF REVISIONS	BY	CHKD	DATE	COUNT	DESCRIPTION OF REVISIONS	BY	CHKD	DATE
△				..	△				..
△				..	△				..
△				..	△				..

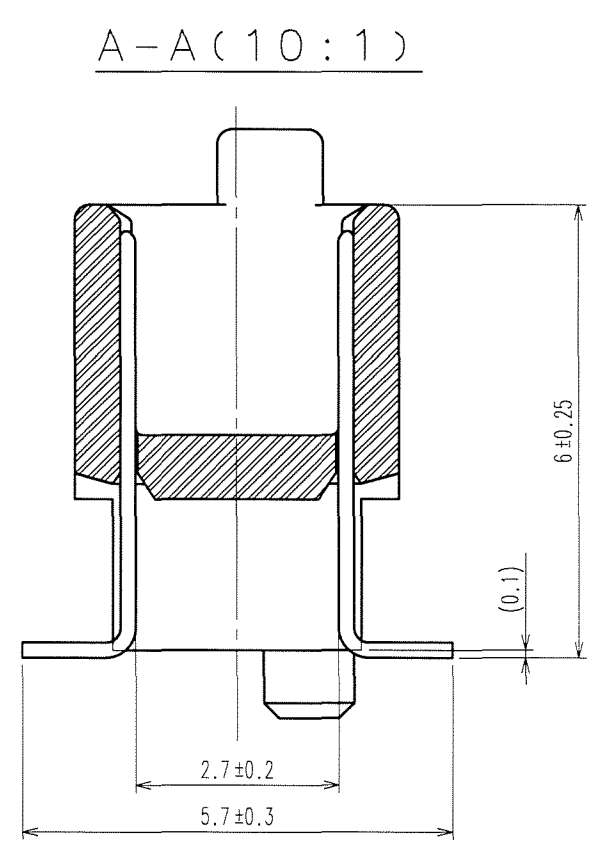
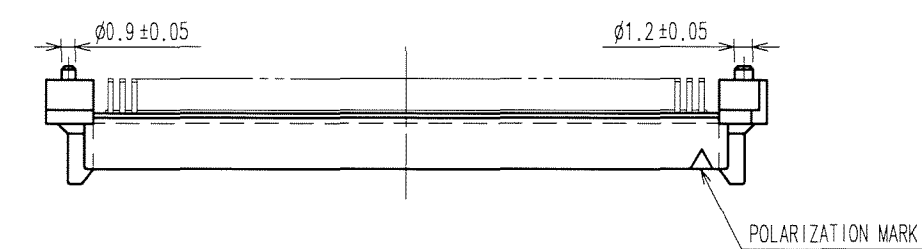
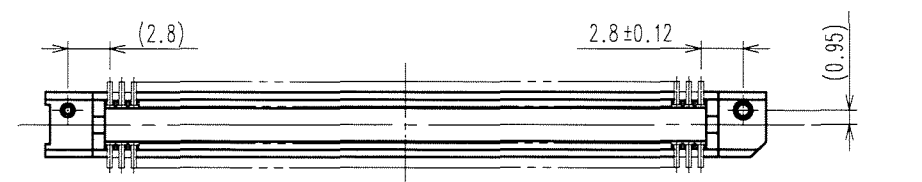
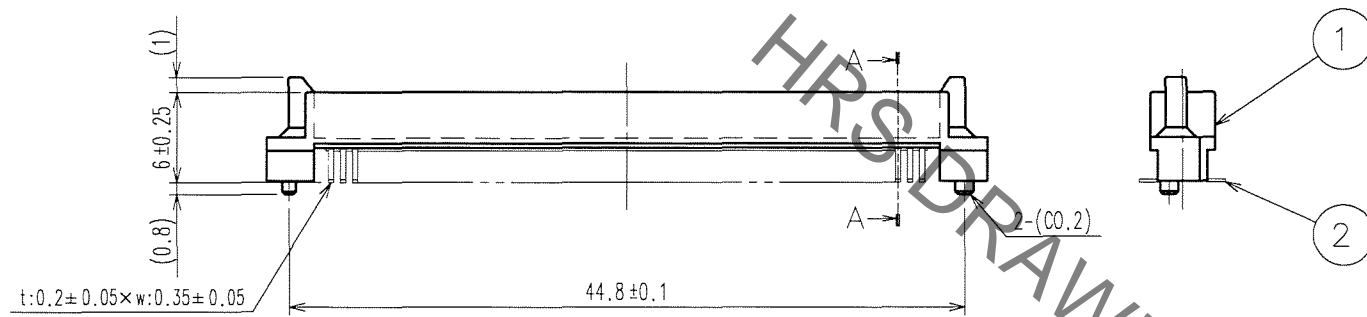
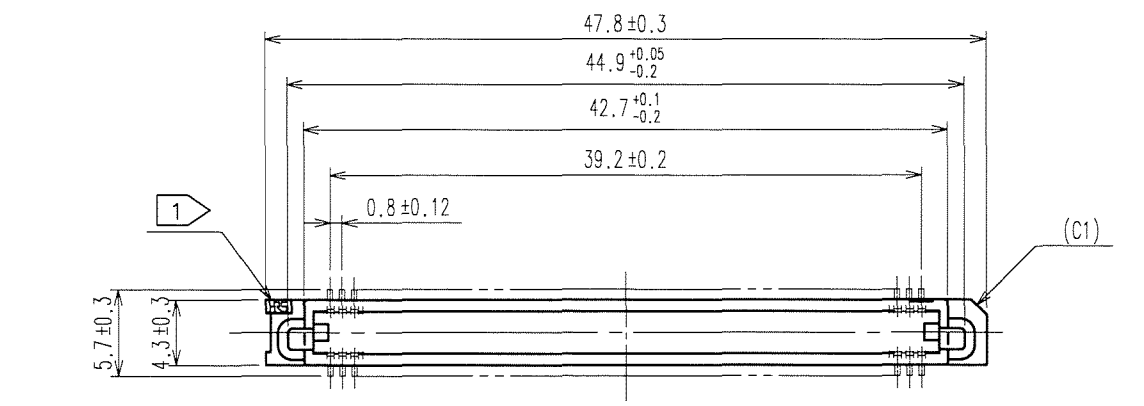

- NOTE 1 HRS MARK SHALL BE OPTIONAL.
 2 LEAD CO-PLANARITY SHALL BE 0.1mm MAX.
 3 EMBOSSED CARRIER TAPE PACKAGING SHALL BE APPLIED TO THIS PRODUCT. SEE NEXT PAGE FOR DETAILS.
 4 THIS PRODUCT HAS TAPE FOR VACUUM PICKUP. SEE NEXT PAGE FOR DETAIL OF STICKING POSITION, ETC.
 5 FOR MODIFICATION, ETC, PREVENTIVE HOLE FOR SINK MARK MAY BE ADDED ACCORDING TO CIRCUMSTANCES.
 6 THE DIMENSIONS IN PARENTHESES ARE FOR REFERENCE.

RECOMMENDED LAND PATTERN DIMENSION OF PCB (MOUNTING SIDE)

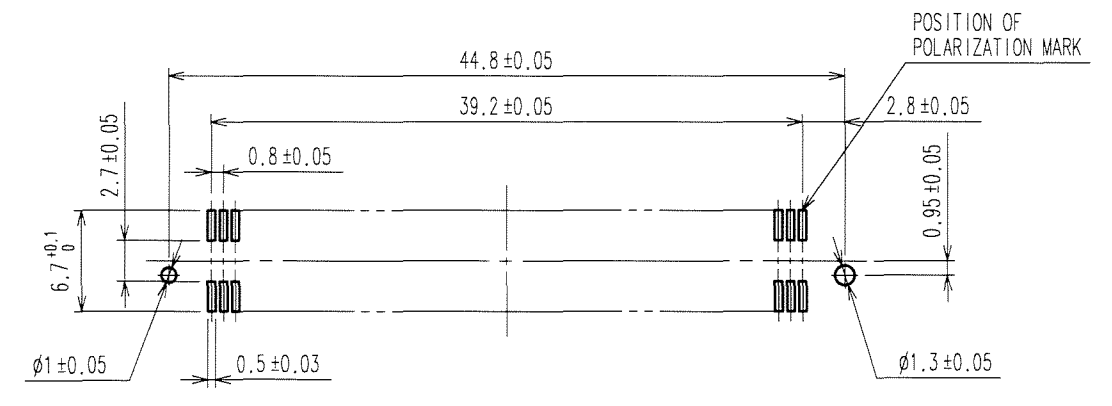

1	PPS	LIGHT BROWN (UL94V-0)	2	PHOSPHOR BRONZE	CONTACT AREA:GOLD 0.1μ m min. LEAD AREA:TIN-PLATING 1μ m min. UNDER PLATING:NICKEL 1μ m min.
NO.	MATERIAL	FINISH, REMARKS	NO.	MATERIAL	FINISH, REMARKS
CODE NO. (OLD)		DRAWN	DESIGNED	CHECKED	APPROVED
		S.KAMIGA	S.KAMIGA	X. Ogawa	H. Okawa
		08.01.21	08.01.21	08.01.21	08.01.21
DRAWING NO.		PART NO.			
EDC3-084976-23		FX6-100P-0.8SV2(93)			
UNITS		CODE NO.			
mm		CL576-0048-7-93		1/2	

TO

Jun.1.2020 Copyright 2020 HIROSE ELECTRIC CO., LTD. All Rights Reserved.
In case of consideration for using Automotive equipment / device which demand high reliability, kindly contact our sales window correspondents.

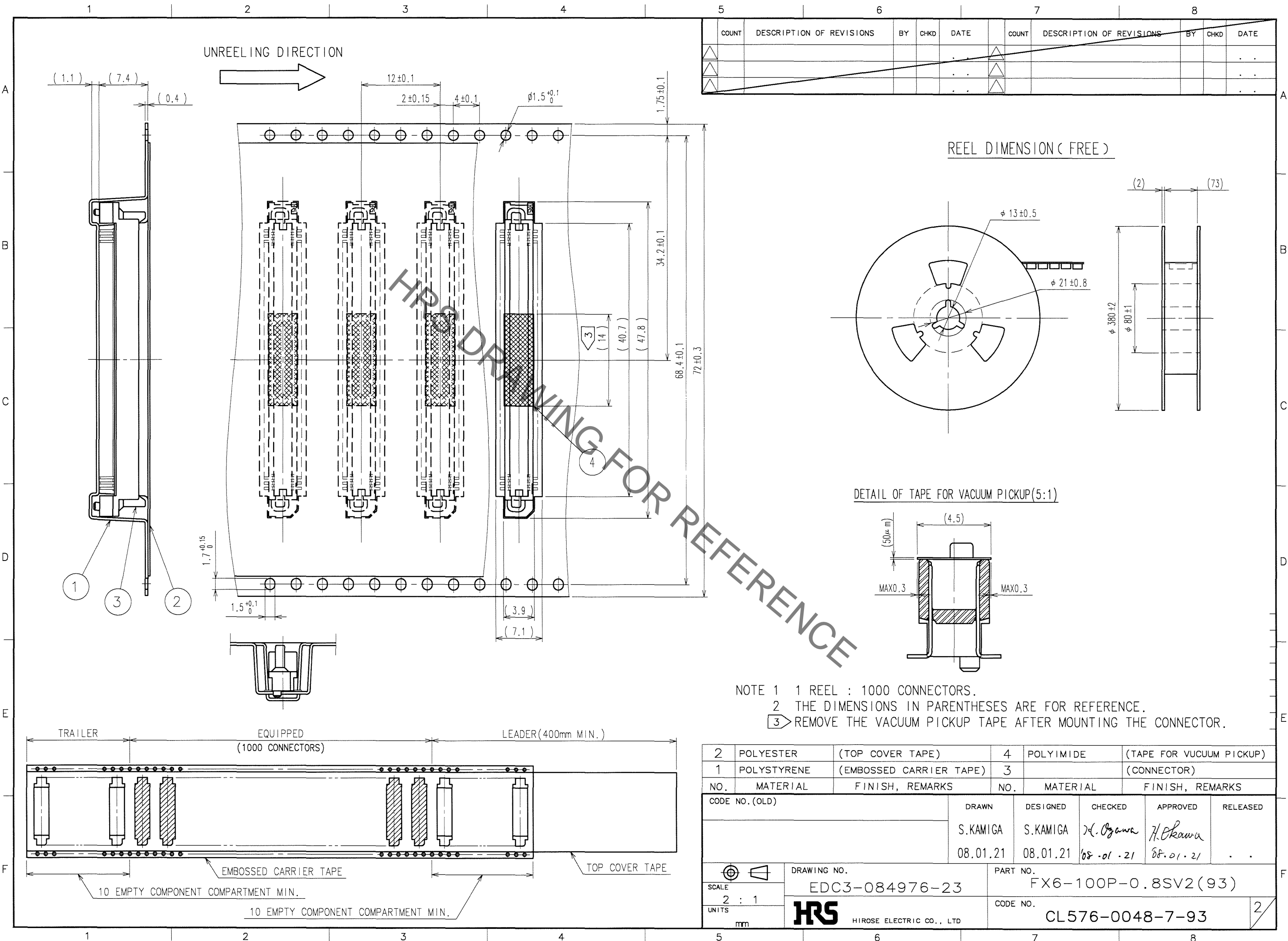

COUNT	DESCRIPTION OF REVISIONS	BY	CHKD	DATE	COUNT	DESCRIPTION OF REVISIONS	BY	CHKD	DATE

REEL DIMENSION (FREE)

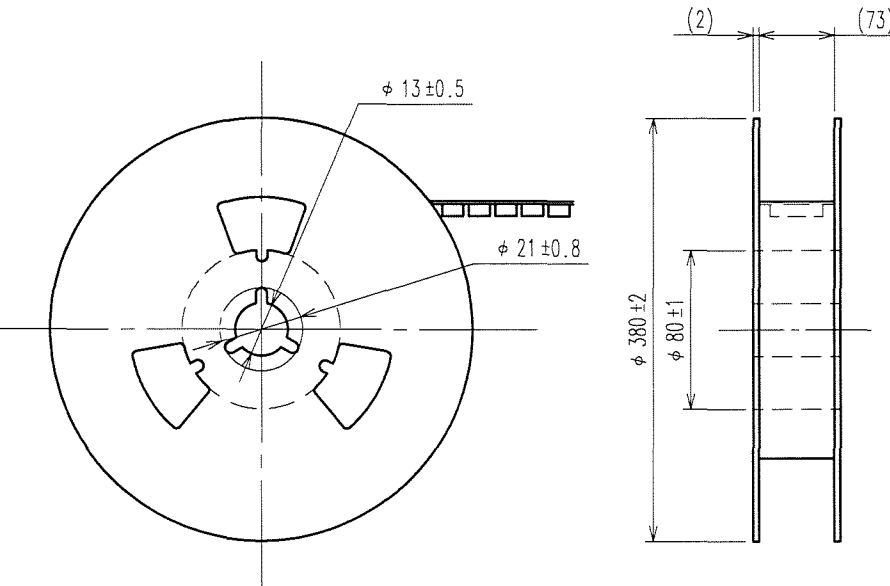

DETAIL OF TAPE FOR VACUUM PICKUP(5:1)

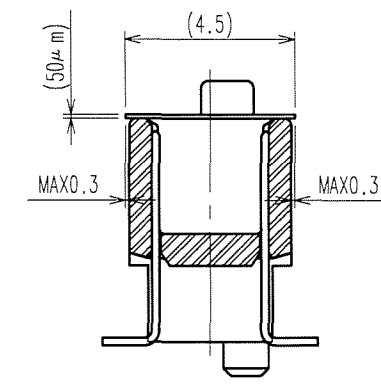

- NOTE 1 1 REEL : 1000 CONNECTORS.
 2 THE DIMENSIONS IN PARENTHESES ARE FOR REFERENCE.
 3 REMOVE THE VACUUM PICKUP TAPE AFTER MOUNTING THE CONNECTOR.

NO.	MATERIAL	FINISH, REMARKS	NO.	MATERIAL	FINISH, REMARKS
2	POLYESTER	(TOP COVER TAPE)	4	POLYIMIDE	(TAPE FOR VUCUUM PICKUP)
1	POLYSTYRENE	(EMBOSSD CARRIER TAPE)	3		(CONNECTOR)

CODE NO. (OLD)	DRAWN	DESIGNED	CHECKED	APPROVED	RELEASED
	S.KAMIGA	S.KAMIGA	H. Ogawa	H. Okawa	
	08.01.21	08.01.21	08-01-21	08-01-21	

SCALE	DRAWING NO.	PART NO.
2 : 1	EDC3-084976-23	FX6-100P-0.8SV2(93)
UNITS	HIROSE ELECTRIC CO., LTD	CODE NO.
mm		CL576-0048-7-93

TO