

May.1.2020 Copyright 2020 HIROSE ELECTRIC CO., LTD. All Rights Reserved.
 In case of consideration for using Automotive equipment / device which demand high reliability, kindly contact our sales window correspondents.

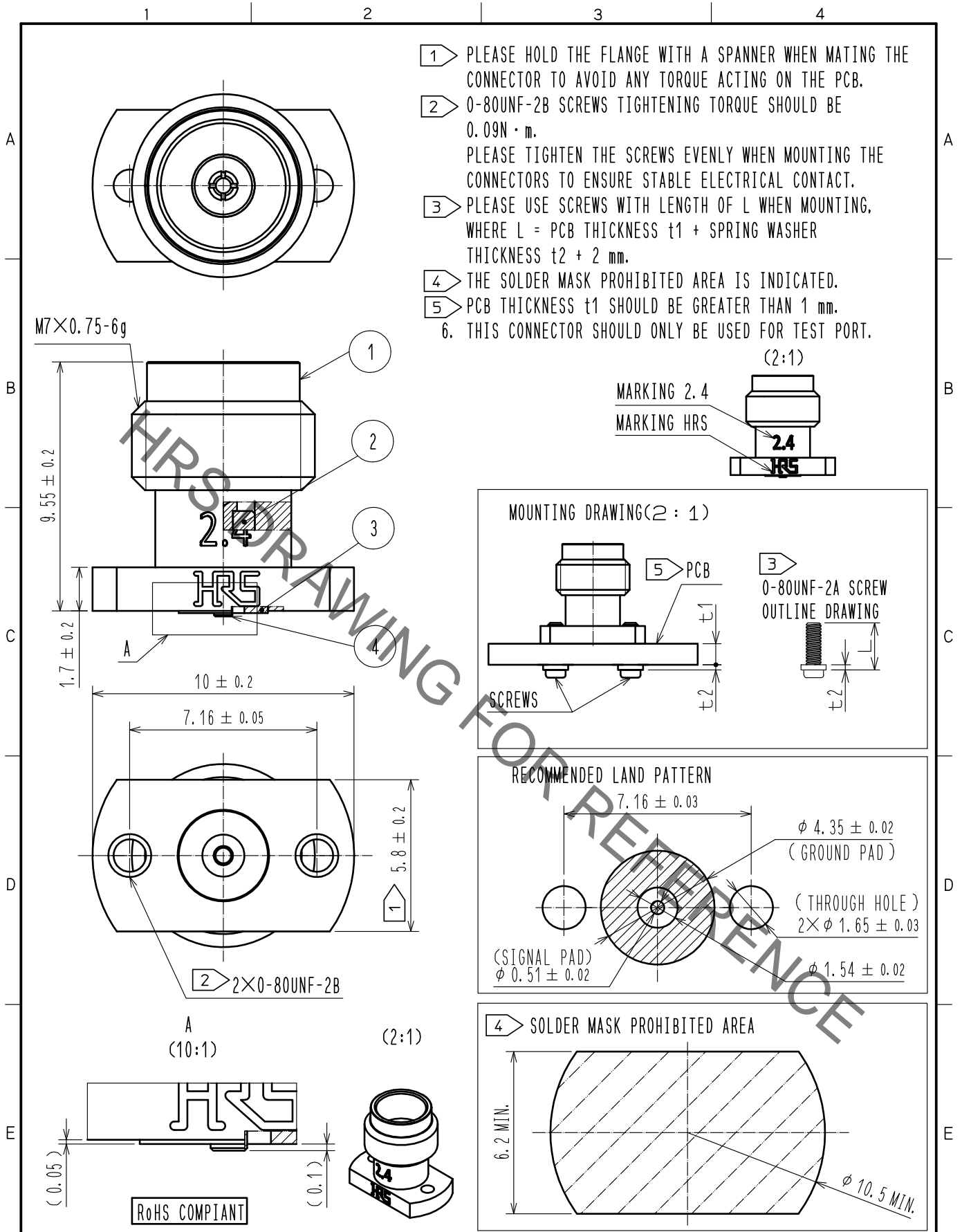

2	PTFE		4	BERYLLIUM COPPER	GOLD PLATING			
1	STAINLESS STEEL	PASSIVATE	3	STAINLESS STEEL	GOLD PLATING			
NO.	MATERIAL	FINISH.	REMARKS	NO.	MATERIAL	FINISH.	REMARKS	
UNITS		SCALE	COUNT	DESCRIPTION OF REVISIONS		DESIGNED	CHECKED	DATE
mm				5 : 1	△			
		APPROVED : KH. IKEDA	18.02.15	DRAWING NO.		EDC-381620-00-00		
HIROSE ELECTRIC CO., LTD.		CHECKED : TS. NOBE	18.02.15	PART NO.		H2. 4-R-SR2-1		
		DESIGNED : AH. MARUYAMA	18.02.15	CODE NO.		CL338-0607-0-00		
		DRAWN : EDWIN TANG	18.02.15			△ 1/1		