

Jun.1.2020 Copyright 2020 HIROSE ELECTRIC CO., LTD. All Rights Reserved.
In case of consideration for using Automotive equipment / device which demand high reliability, kindly contact our sales window correspondents.

ELV. RoHS COMPLIANT

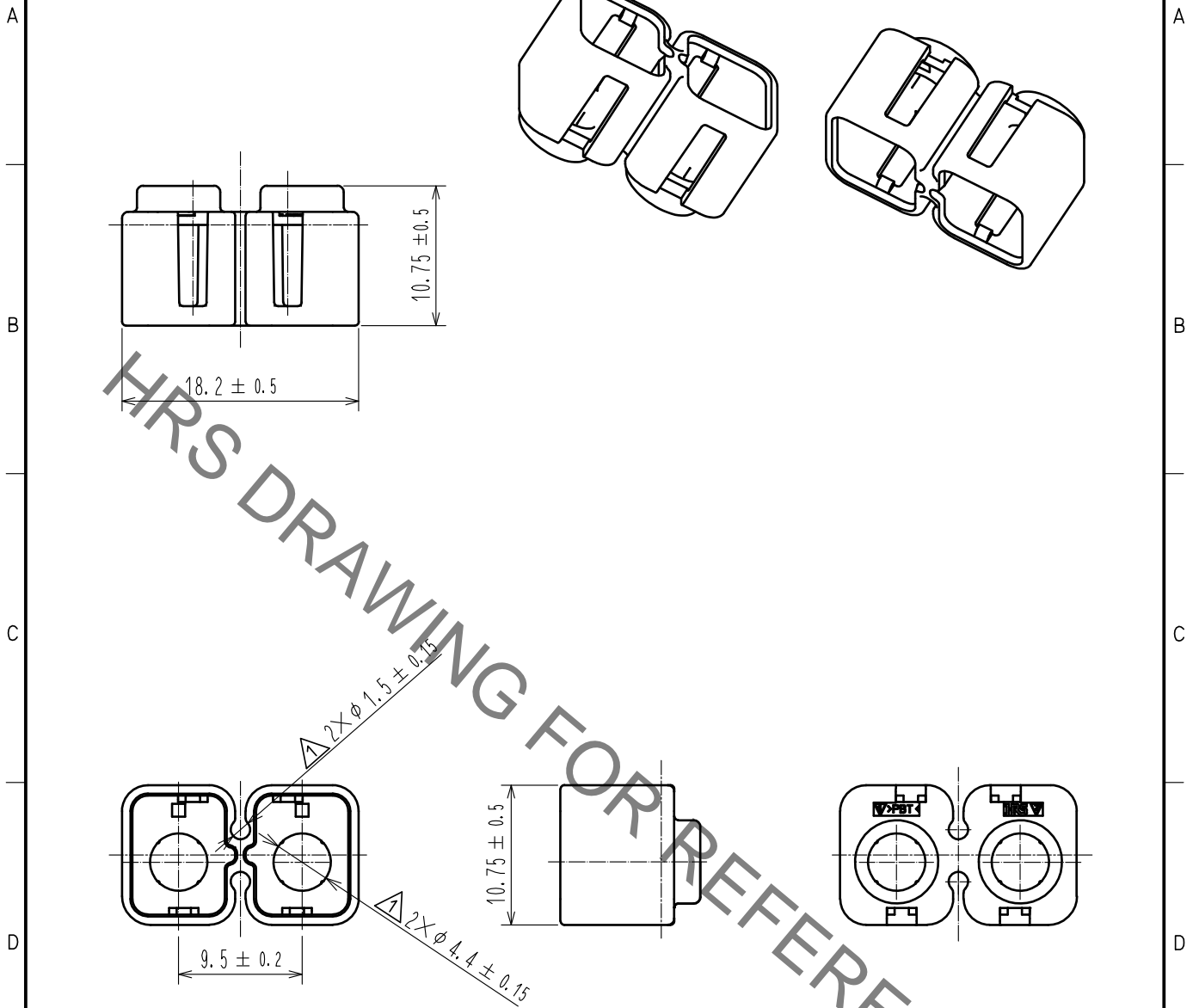

Note 1. A pack of 100
 2. Assembly procedure refer to ETAD-T0573-00
 3. Applicable cable for power crimp contact : $\phi 4.0 \sim 4.4\text{mm}$.
 Applicable cable for check crimp contact : $\phi 1.5\text{mm MAX.}$

1	PBT	BLACK, UL94 V-0	2	-	-
NO.	MATERIAL	FINISH . REMARKS	NO.	MATERIAL	FINISH . REMARKS
UNITS mm		SCALE 2 : 1	COUNT 3	DESCRIPTION OF REVISIONS DIS-T-00004363	DESIGNED TS. SHIMIZU
					CHECKED AH. EDASHIGE
					DATE 20190228
HRS HIROSE ELECTRIC CO., LTD.	APPROVED	:HK. UMEHARA	20161128	DRAWING NO.	EDC-370501-00-00
	CHECKED	:HK. UMEHARA	20161128	PART NO.	HVH-280-2/2P-H0
	DESIGNED	:KO. NAKAMURA	20161128	CODE NO.	CL778-0506-0-00
	DRAWN	:KO. NAKAMURA	20161128		