

Jun.1.2020 Copyright 2020 HIROSE ELECTRIC CO., LTD. All Rights Reserved.
 In case of consideration for using Automotive equipment / device which demand high reliability, kindly contact our sales window correspondents.

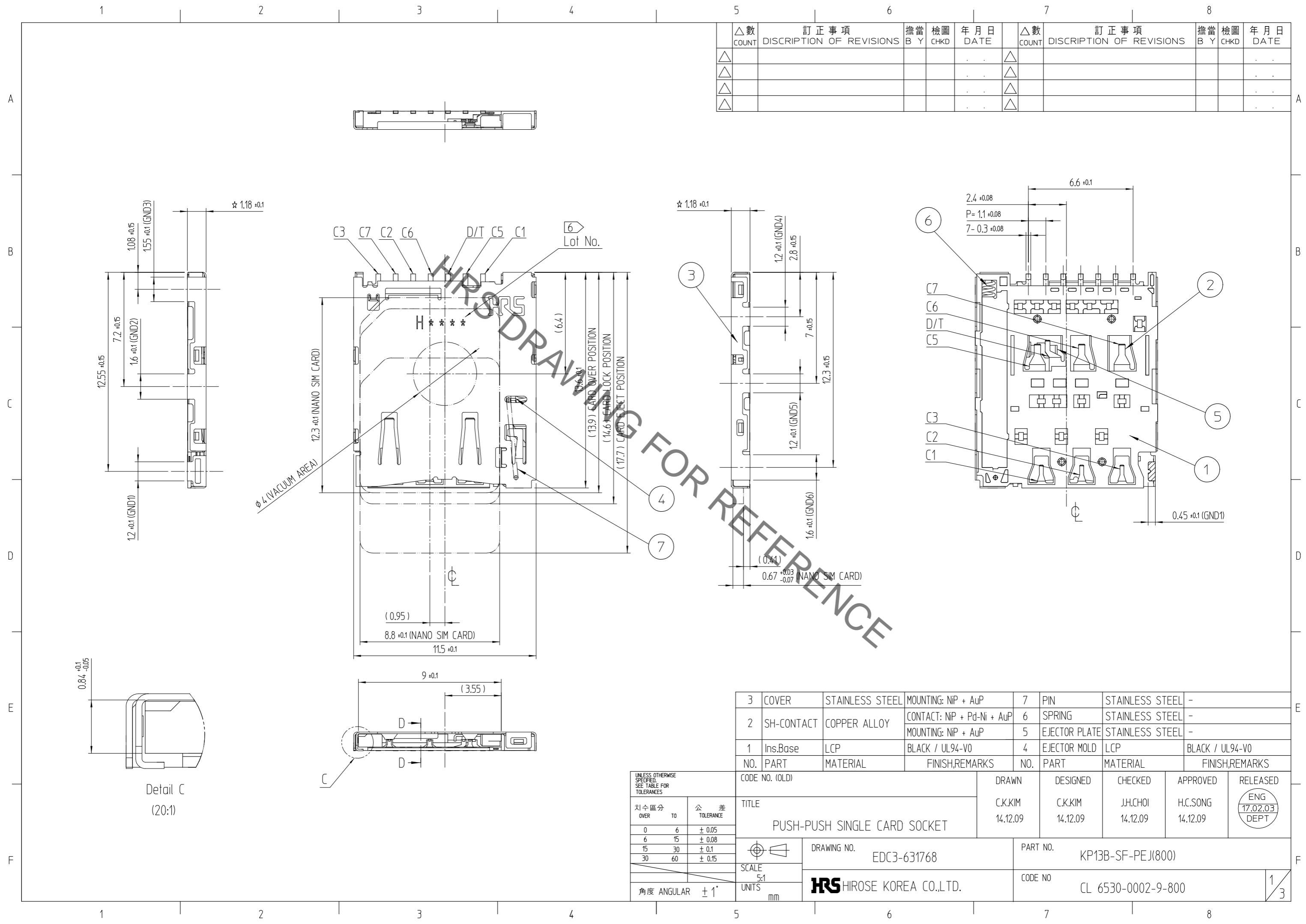

△數 COUNT	訂正事項 DISCRIPTION OF REVISIONS	擔當 B Y	檢圖 CHKD	年月日 DATE	△數 COUNT	訂正事項 DISCRIPTION OF REVISIONS	擔當 B Y	檢圖 CHKD	年月日 DATE
△					△				
△					△				
△					△				
△					△				

3	COVER	STAINLESS STEEL	MOUNTING: NIP + AuP	7	PIN	STAINLESS STEEL	-
2	SH-CONTACT	COPPER ALLOY	CONTACT: NIP + Pd-Ni + AuP MOUNTING: NIP + AuP	6	SPRING	STAINLESS STEEL	-
1	Ins.Base	LCP	BLACK / UL94-V0	5	EJECTOR PLATE	STAINLESS STEEL	-
NO.	PART	MATERIAL	FINISH,REMARKS	NO.	PART	MATERIAL	FINISH,REMARKS

公差 TOLERANCE	0	6	15	30	60
±0.05					
±0.08					
±0.1					
±0.15					

UNLESS OTHERWISE SPECIFIED, SEE TABLE FOR TOLERANCES	CODE NO. (OLD)		DRAWN	DESIGNED	CHECKED	APPROVED	RELEASED
角 度 ANGULAR	TITLE PUSH-PUSH SINGLE CARD SOCKET		C.K.KIM 14.12.09	C.K.KIM 14.12.09	J.H.CHOI 14.12.09	H.C.SONG 14.12.09	ENG 17.02.03 DEPT
±1'	SCALE 5:1	DRAWING NO. EDC3-631768	PART NO. KP13B-SF-PEJ(800)		CODE NO. CL 6530-0002-9-800		
UNITS mm		HRS HIROSE KOREA CO.,LTD.					1/3

Jun.1.2020 Copyright 2020 HIROSE ELECTRIC CO., LTD. All Rights Reserved.
In case of consideration for using Automotive equipment / device which demand high reliability, kindly contact our sales window correspondents.

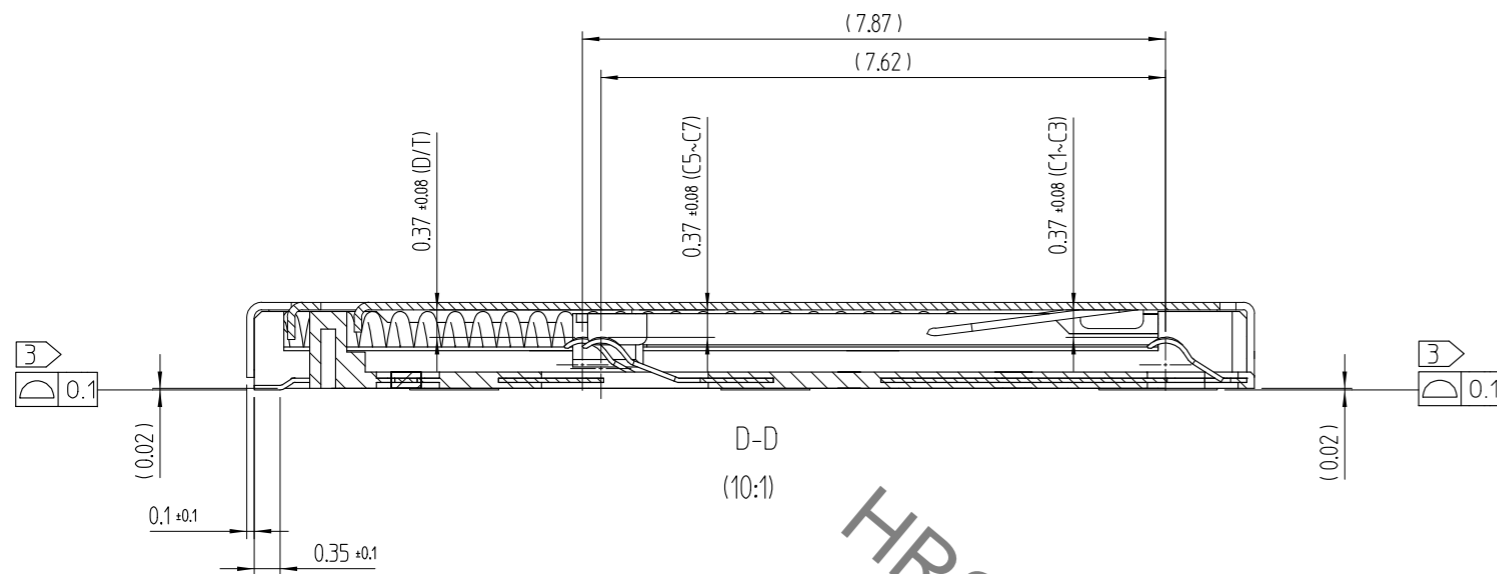

NOTE 1. ☆ MARK IS C.T.Q (CRITICAL TO QUALITY) POINT
2. CARD DETECTION SWITCH

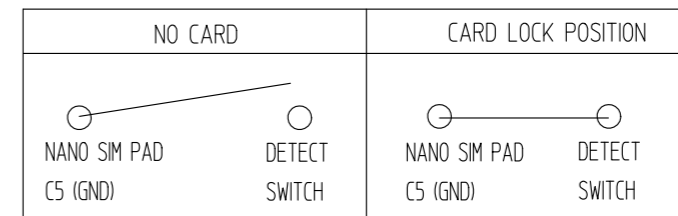

③ CO-PLANARITY SHALL BE 0.1mm MAX(BEFORE & AFTER REFLOW)

④ NO PATTERNS PERMITTED IN THIS OBLIQUE - HATCHED AREA

RECOMMENED P.C.B PATTERN LAYOUT (TOLERANCE : ±0.05)

RECOMMEND METAL MASK THICKNESS : 0.12mm

④ NO PATTERNS PERMITTED IN THIS OBLIQUE

TOLERANCE : ±0.05

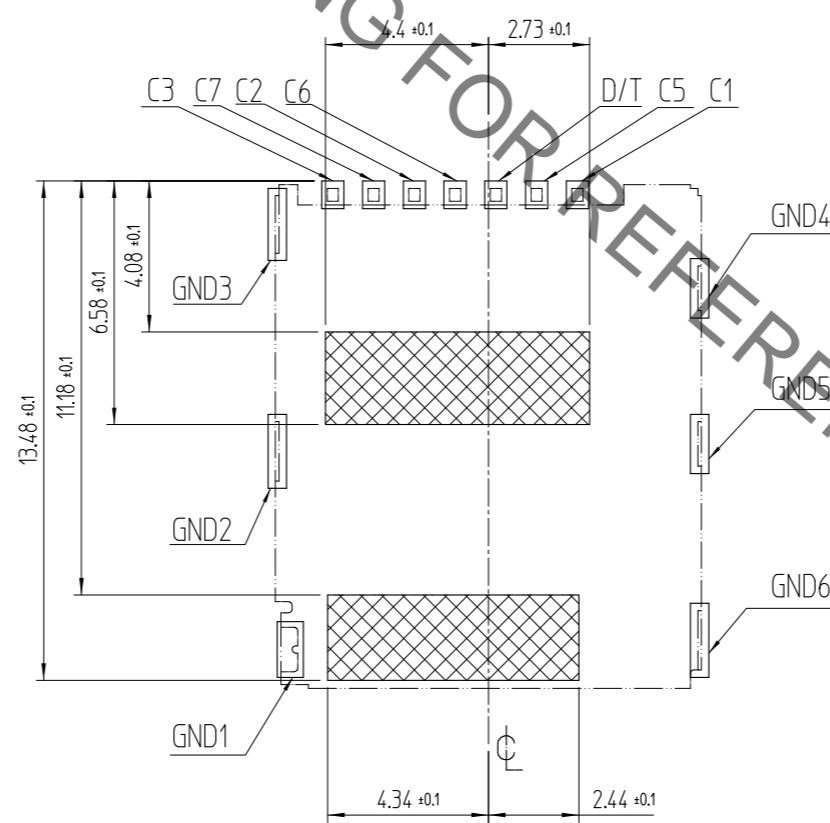
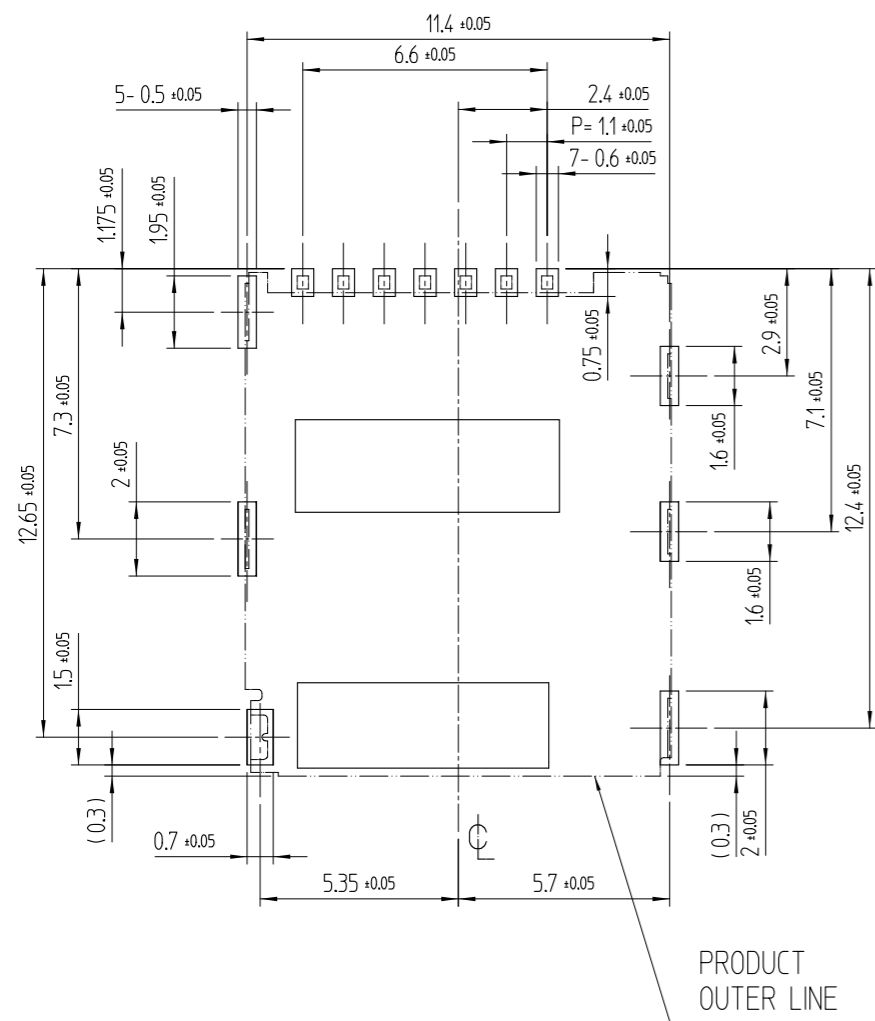

PIN No.	Name
C1	Vcc
C2	RST
C3	CLK
C4	Reserved
C5	GND
C6	Vpp
C7	I/O
C8	Reserved

NANO SIM CARD ASSIGNMENT

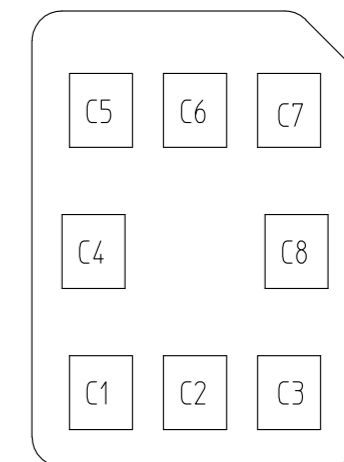

NANO SIM CARD PAD LAY OUT

Jun.1.2020 Copyright 2020 HIROSE ELECTRIC CO., LTD. All Rights Reserved.
 In case of consideration for using Automotive equipment / device which demand high reliability, kindly contact our sales window correspondents.

5 DRAWING FOR PACKING

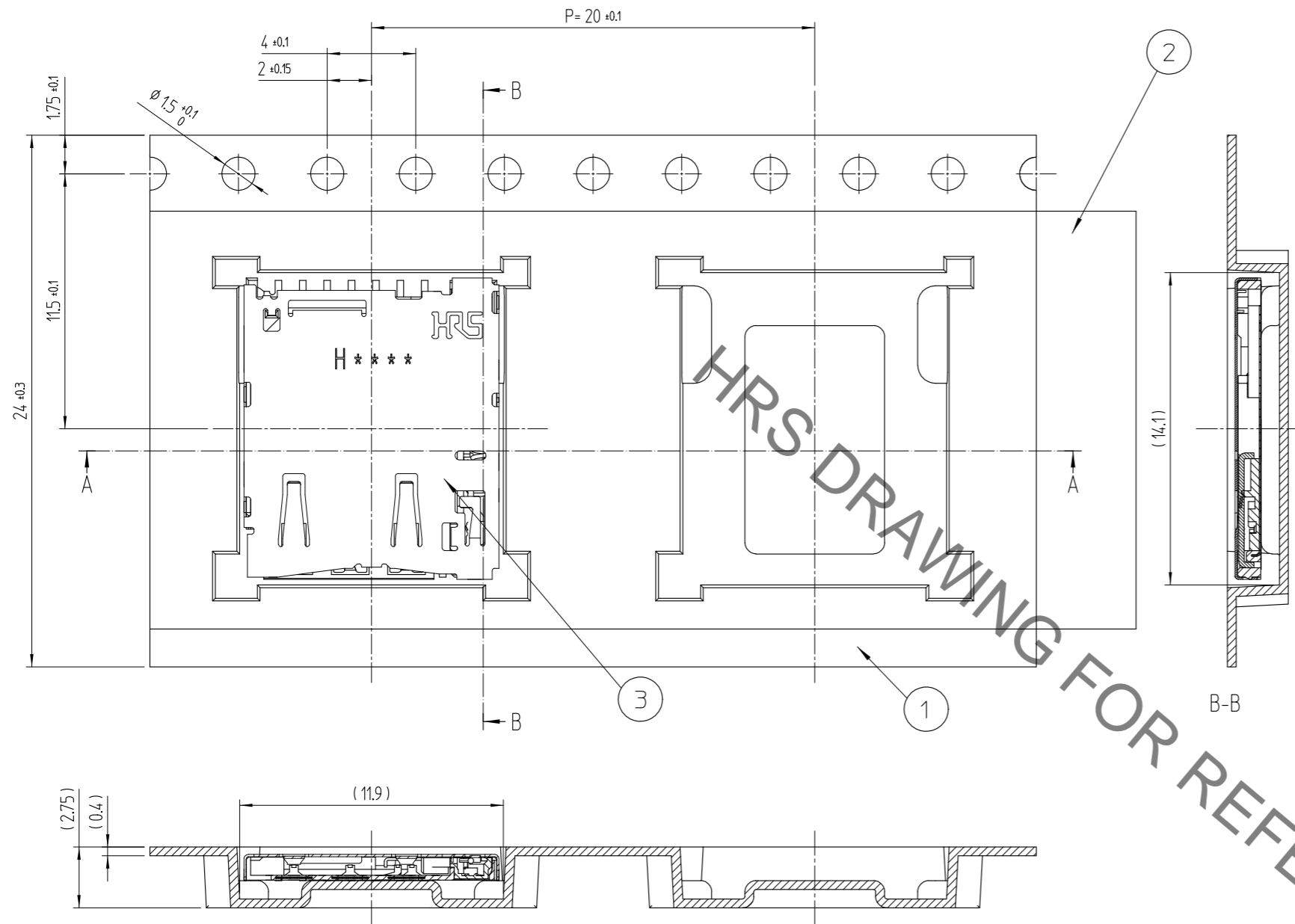

DETAIL OF REEL

REVISED CONFIGURATION

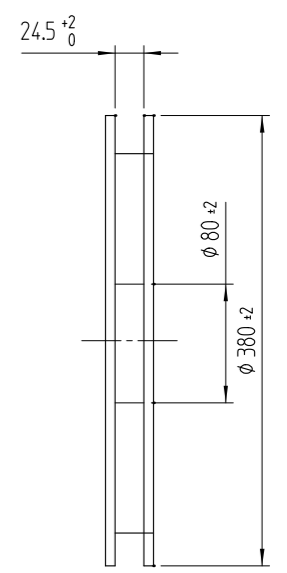
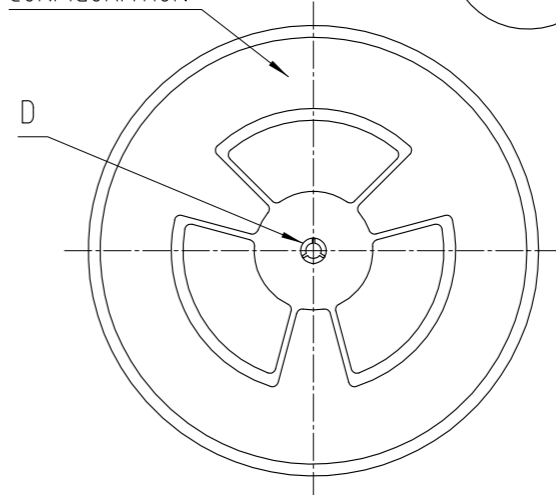

- 5 PACKING TYPE :TAPE AND 1,500PCS PER 1REEL .
- 6 MANUFACTURING DATE SYSTEM

H 6 1 26 1

PRODUCTION LINE : LINE No.
 DATE : 26TH
 MONTH : JAN
 YEAR : 2016
 SUPPLIER : HIROSE KOREA

7 THE DIMENSIONS OF CUSTOMER DRAWING ARE INITIAL DIMENSIONS OF PRODUCT. NOT AFTER THE REFLOW.

6 TABLE.1

YEAR	MONTH	DATE							
YEAR	SYMBOL	MONTH	SYMBOL	DATE	SYMBOL	DATE	SYMBOL	DATE	SYMBOL
2016	6	Jan.	1	1	1	11	11	21	21
2017	7	Feb.	2	2	2	12	12	22	22
2018	8	Mar.	3	3	3	13	13	23	23
2019	9	Apr.	4	4	4	14	14	24	24
2020	0	May.	5	5	5	15	15	25	25
2021	1	Jun.	6	6	6	16	16	26	26
2022	2	Jul.	7	7	7	17	17	27	27
2023	3	Aug.	8	8	8	18	18	28	28
2024	4	Sep.	9	9	9	19	19	29	29
2025	5	Oct.	A	10	10	20	20	30	30
		Nov.	B					31	31
		Dec.	C						

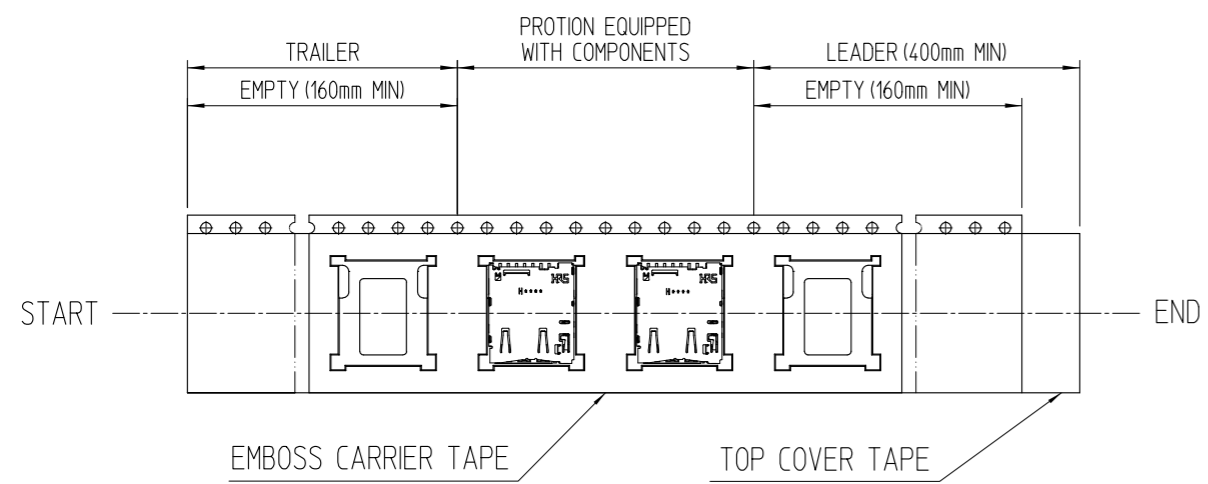

3	(CONNECTOR)	
2	TOP COVER TAPE	POLYESTER
1	EMBOSS CARRIER TAPE	PS
No.	PART	MATERIAL
HRS HIROSE KOREA CO.,LTD.		圖番 DRAWING NO. EDC3-631768

3/3