

May.1.2020 Copyright 2020 HIROSE ELECTRIC CO., LTD. All Rights Reserved.
 2 In case of consideration for using Automotive equipment / device which demand high reliability, kindly contact our sales window correspondents.

COUNT	DESCRIPTION OF REVISIONS	BY	CHKD	DATE	COUNT	DESCRIPTION OF REVISIONS	BY	CHKD	DATE
1	RE-J-02130	N.S.R.K		'04. 2. 9					
5	RE-J-02188	N.S.R.K		'04. 6. 21					

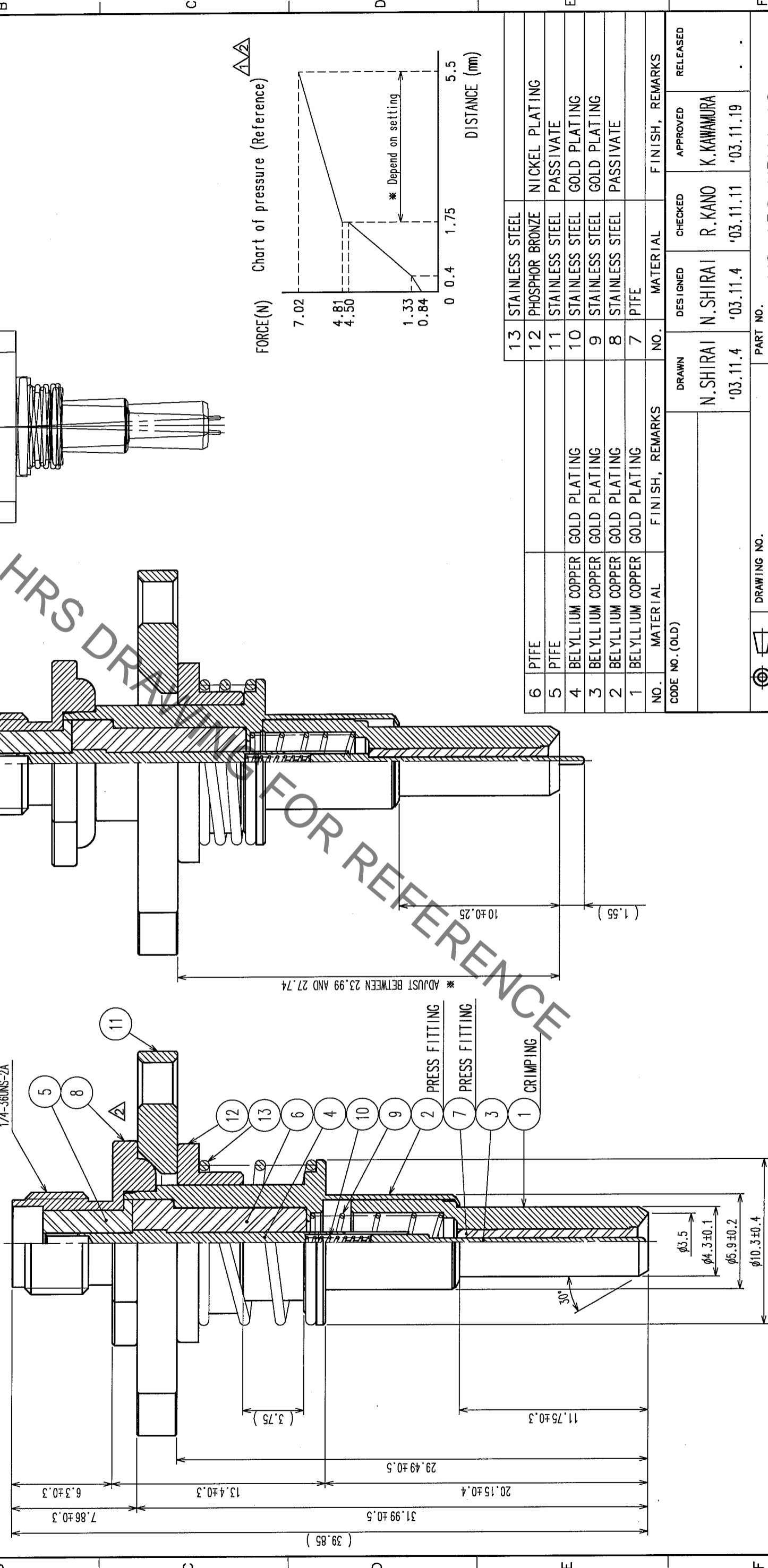
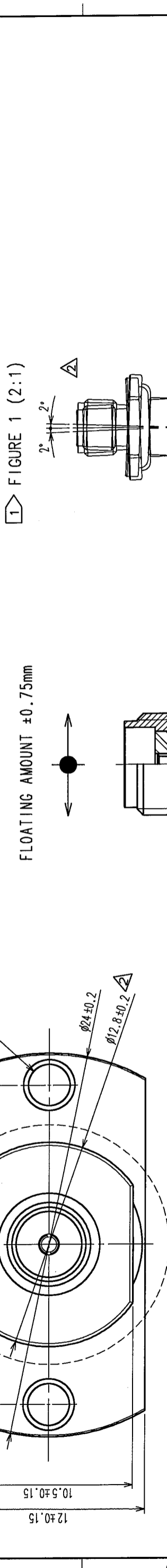

FLOATING AMOUNT ±0.75mm

1 FIGURE 1 (2:1)

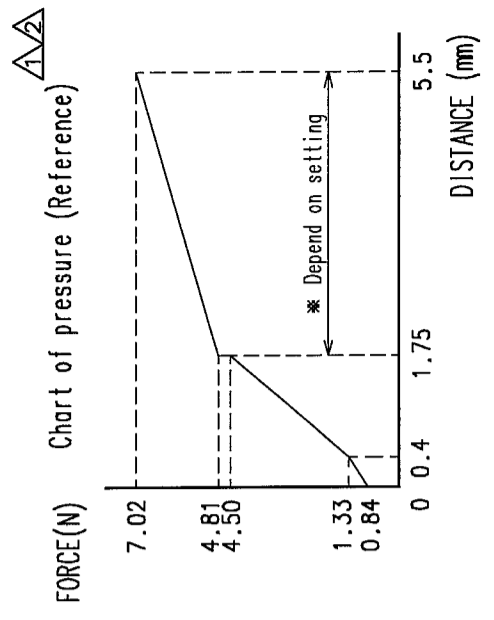

NO.	MATERIAL	FINISH, REMARKS	NO.	MATERIAL	FINISH, REMARKS
13	STAINLESS STEEL		13	STAINLESS STEEL	
12	PHOSPHOR BRONZE		12	PHOSPHOR BRONZE	NICKEL PLATING
11	STAINLESS STEEL		11	STAINLESS STEEL	PASSIVATE
10	STAINLESS STEEL		10	STAINLESS STEEL	GOLD PLATING
9	STAINLESS STEEL		9	STAINLESS STEEL	GOLD PLATING
8	STAINLESS STEEL		8	STAINLESS STEEL	PASSIVATE
7	PTFE		7	PTFE	

CODE NO. (OLD)		DRAWN		DESIGNED		CHECKED		APPROVED		RELEASED	
		N. SHIRAI		N. SHIRAI		R. KANO		K. KAWAMURA			
		'03.11.4		'03.11.4		'03.11.11		'03.11.19			

NOTE 1 Mating angle which is less than 2 degree is acceptable. (Refer to fig.1)
 2 No obstacles in this area.

TO	
RFD	

DRAWING NO.	EDC3-180384	PART NO.	MS-156-HRMJ-12
SCALE	4 : 1	CODE NO.	CL358-0196-6
UNITS	mm		