

Jun.1.2020 Copyright 2020 HIROSE ELECTRIC CO., LTD. All Rights Reserved.
In case of consideration for using Automotive equipment / device which demand high reliability, kindly contact our sales window correspondents.

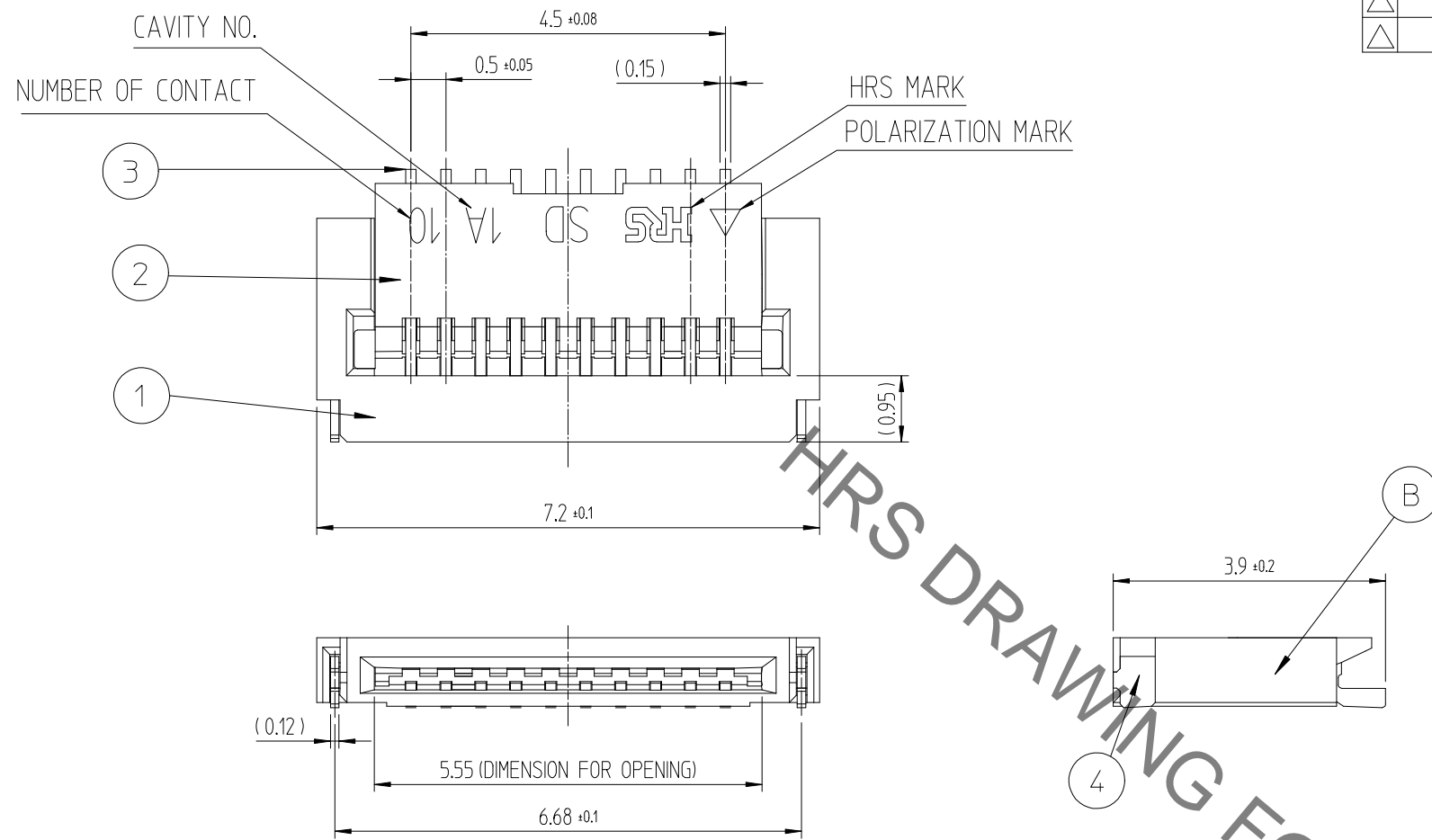

RECOMMENDED LAND PATTERN, METAL MASK (FREE)
RECOMMENDED METAL MASK THICKNESS: t=0.10

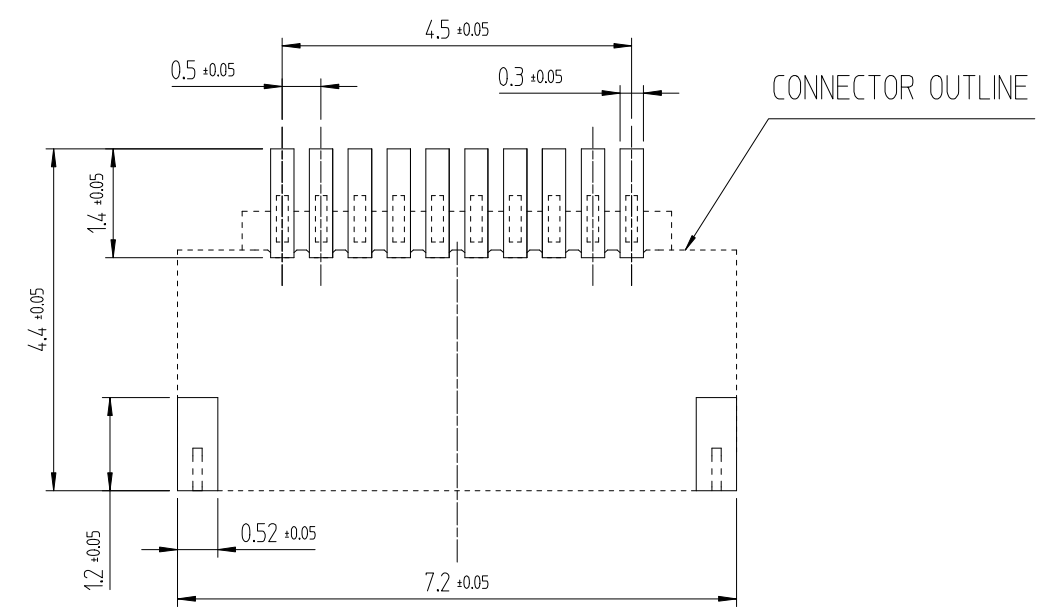

RECOMMENDED FPC (FREE)

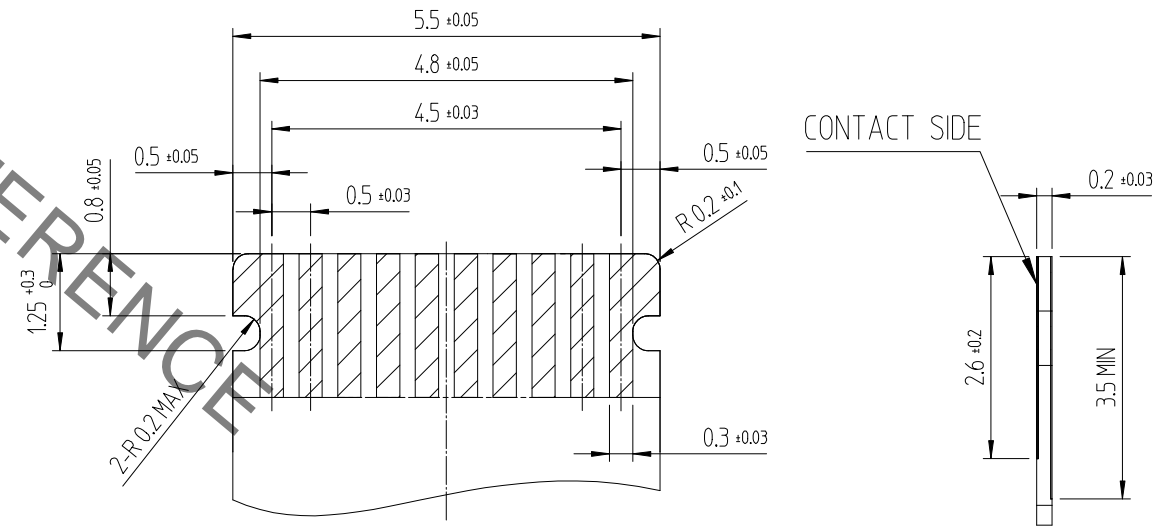

VIEW B(20:1)

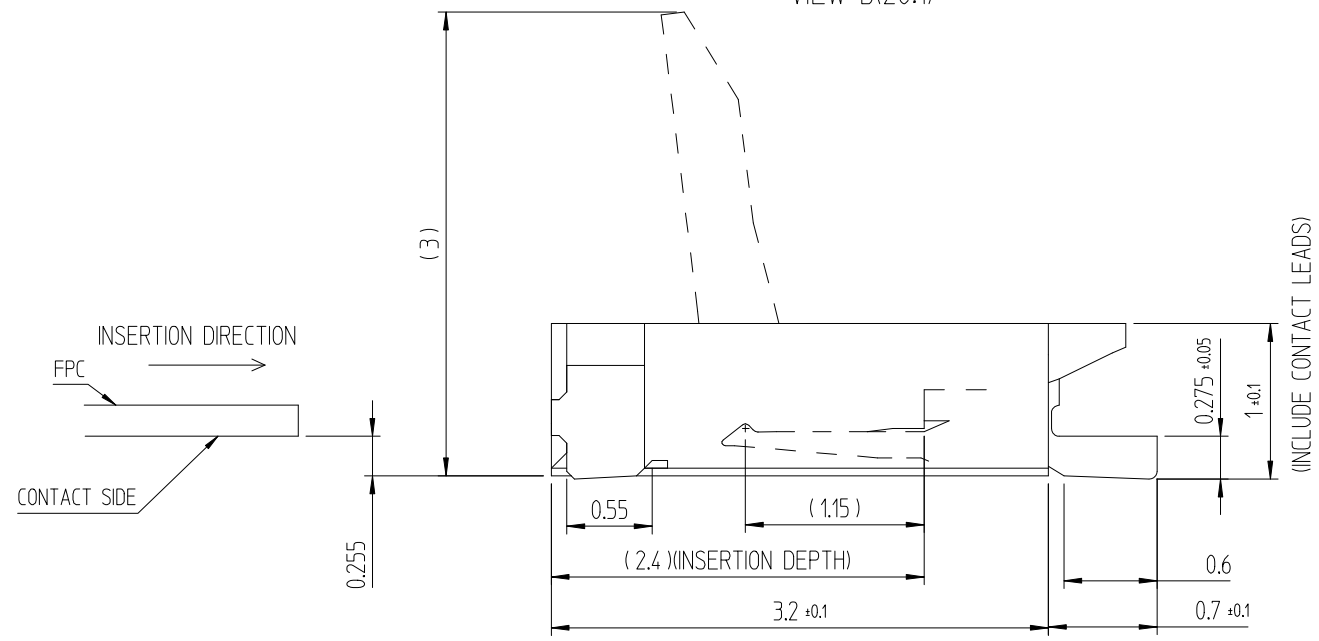

NOTE 1 LEAD CO-PLANARITY INCLUDING REINFORCED METAL FITTINGS SHALL BE 0.1MAX.
2 TO BE DELIVERED WITH TAPE AND REEL PACKAGES.

△數 COUNT	訂正事項 DISCRPTION OF REVISIONS	擔當 B	檢圖 CHKD	年月日 DATE	△數 COUNT	訂正事項 DISCRPTION OF REVISIONS	擔當 B	檢圖 CHKD	年月日 DATE
△				..	△				..
△				..	△				..
△				..	△				..

2	PPS	BLACK	UL94V-0	4	PHOSPHOR BRONZE	TIN PLATING 1μm MIN. OVER NICKEL 1μm MIN.				
1	LCP	BEIGE	UL94V-0	3	PHOSPHOR BRONZE	(CONTACT AREA) GOLD PLATING, OVER NICKEL 1μm MIN (LEAD) GOLD PLATING, OVER NICKEL 1μm MIN (OTHER) NICKEL PLATING 1μm MIN				
NO.	MATERIAL	FINISH,REMARKS		NO.	MATERIAL	FINISH,REMARKS				
CODE NO. (OLD)				DRAWN	DESIGNED	CHECKED	APPROVED	RELEASED		
				KANG 15.06.05 M.G	KANG 15.06.05 M.G	CHO 15.06.05 D.H	SONG 15.06.05 H.C	ENG 18.12.10 DEPT		
DRAWING NO. EDC3-631685-80				PART NO. TF12SD-10S-0.5SH (800)						
SCALE 10:1				UNITS mm				CODE NO. CL 6586-0019-6-800		1/4
HRS HIROSE KOREA CO.,LTD.										

Jun.1.2020 Copyright 2020 HIROSE ELECTRIC CO., LTD. All Rights Reserved.
In case of consideration for using Automotive equipment / device which demand high reliability, kindly contact our sales window correspondents.

EMBOSS CARRIER TAPE DIMENSION (TAPE WIDTH TO 24mm MAX)

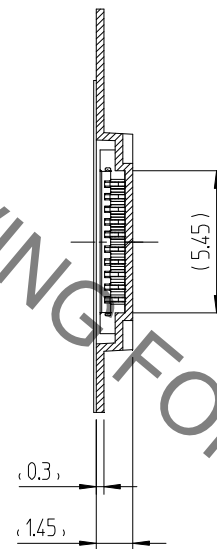
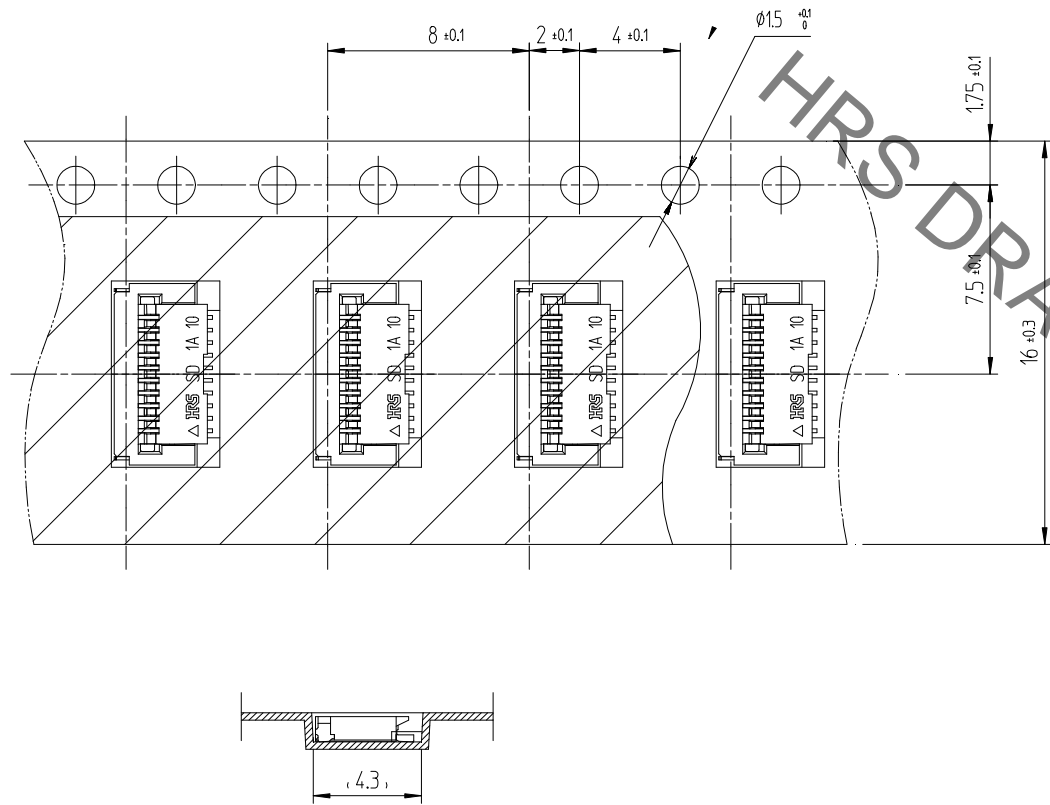

REEL DIMENSION(FREE)

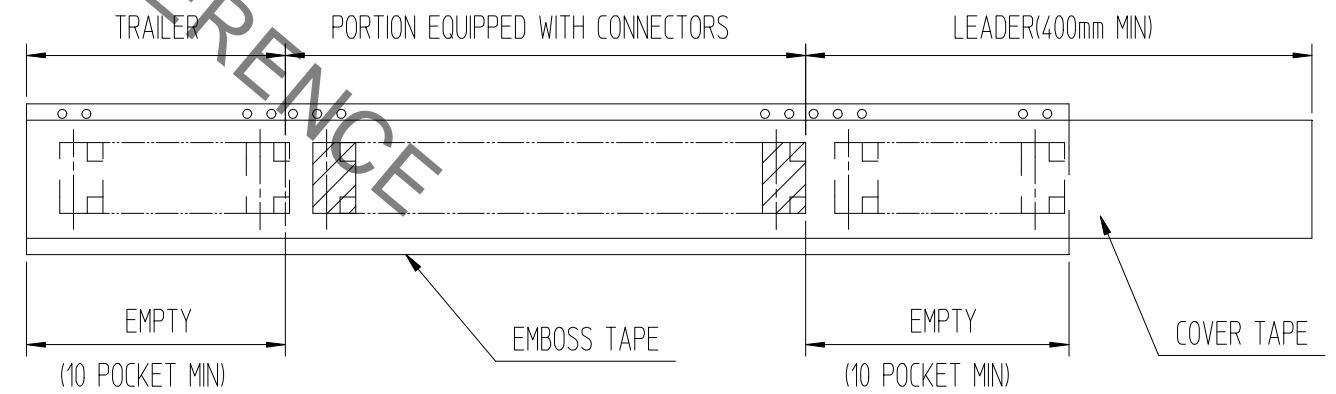
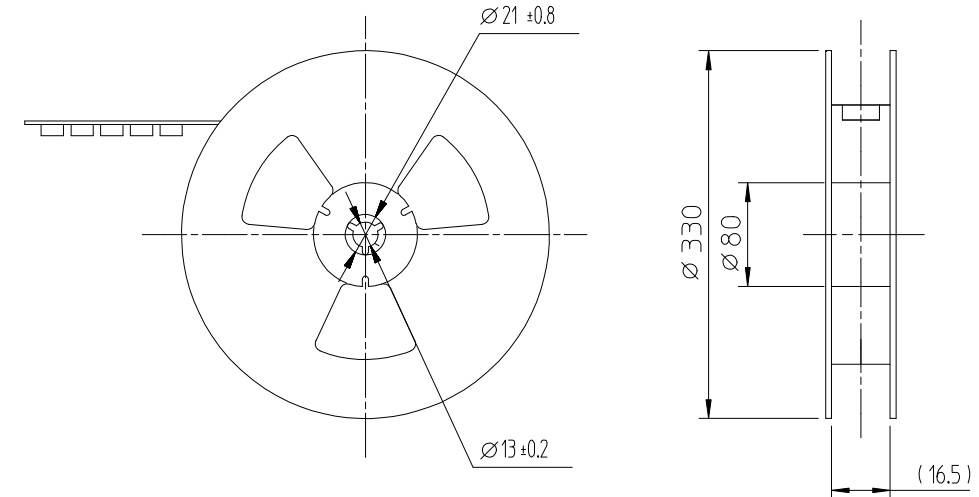

NOTE 1. 1REEL CONTAINS 5,000PCS.

This connector requires dslicate and careful handing.
Read through the instructions shown below and the connector properly.
Each values indicating here are for reference and may differ from standard value.

[INSTRUCTIONS FOR MOUNTING ON THE BOARD]

- ◆ Warp of Board
Minimize warp of the board as possible
Lead co-planarity including reinforced metal fitting is 0.08mm or less
Too much warp of the board may result in a soldering.
- ◆ Load to Connector
Do not apply a force of 0.5N or more to the connector before mounting it on the board.
Otherwise, the connector may be broken.
Do not warp the FPC or operate the connector before mounting it.
- ◆ Load to board
°Splitting a large board into several pieces
°Screwing the board
Avoid the handling described above so that no force is exerted on the board during the assembly process.
Otherwise, the connector may become defective.
- ◆ Amount of Warp
The warp of a 100-mmwide board should be 0.5mm or less.
The warp of board suffers stress on connector and connector may become defective.

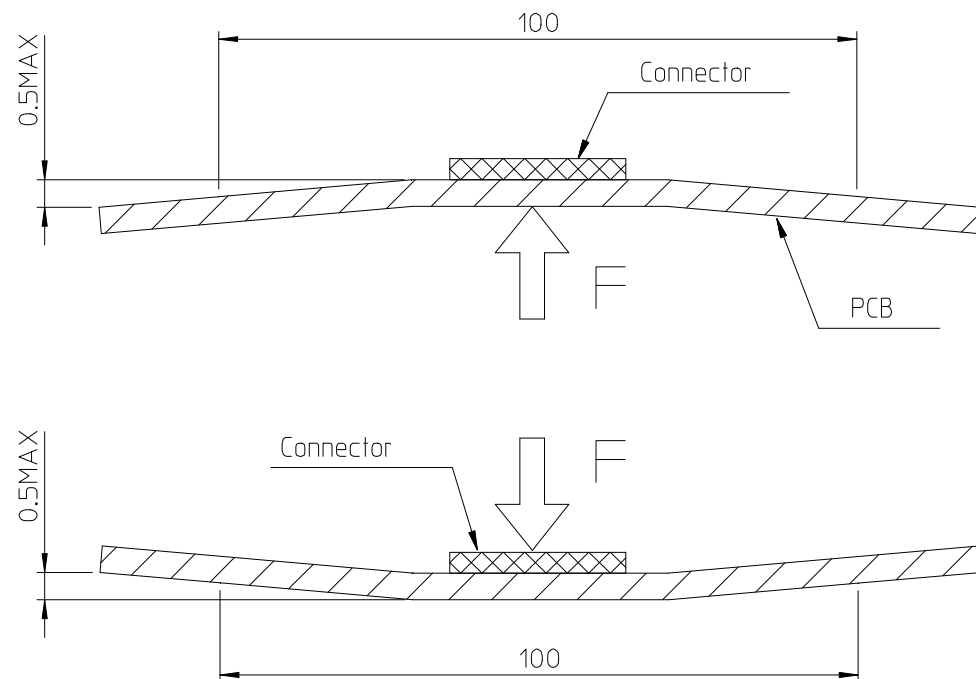

[INSTRUCTIONS ON INSERTING FFC/FPC AND CONNECTOR]

- ◆ Use of the Actuator
1. Be very careful not to apply excessive force when releasing the Actuator.
in the initial position (with no FPC inserted)
if you use your nail or finger as shown, the terimals may be deformed.

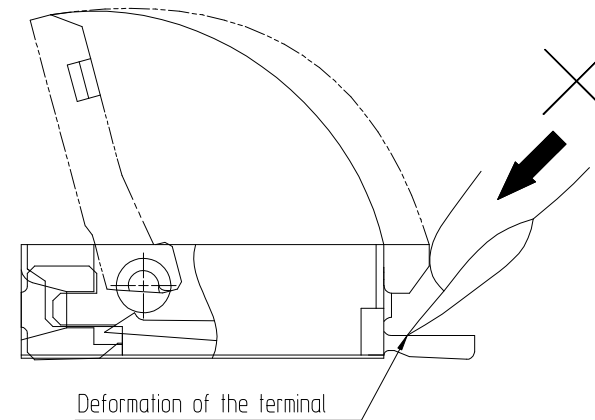

- 2. The actuator rotates around the rotational axis as shown below.
Please rotate the actuator.

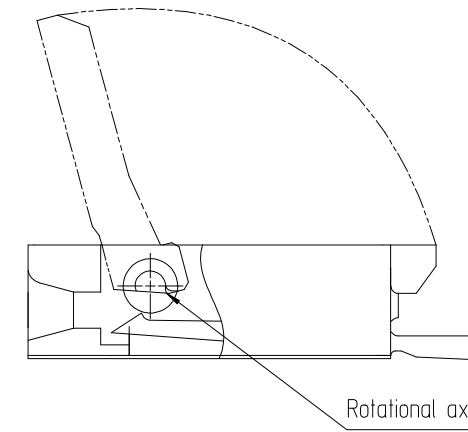

- 3. Please do not push downwards to the Actuator with more than 0.5N force, as shown below.
Otherwise, the Actuator may fall off or be damaged.

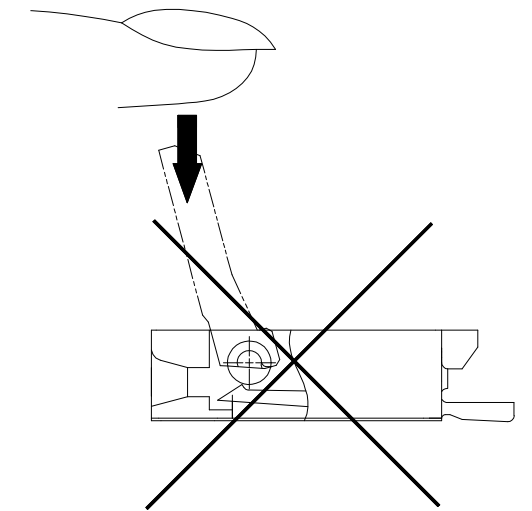

- 4. The actuator will not open more than 95°.
Do not apply any force backward beyond this point.
Otherwise the actuator may come off or braek.

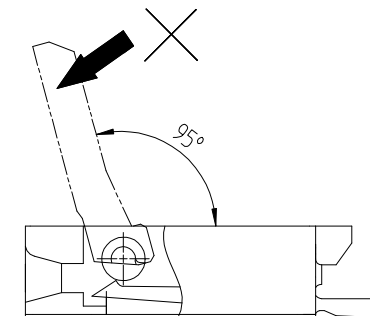

Jun.1.2020 Copyright 2020 HIROSE ELECTRIC CO., LTD. All Rights Reserved.
In case of consideration for using Automotive equipment / device which demand high reliability, kindly contact our sales window correspondents.

5. Move the actuator at approximately the center.
(It may break if operate the edge of the actuator with FPC inserted.)
6. Do not pinch or pick the actuator to lift it as shown below, Otherwise, it may break.
(Do not carry out any operation other than rotating the actuator as shown in 2 above.)

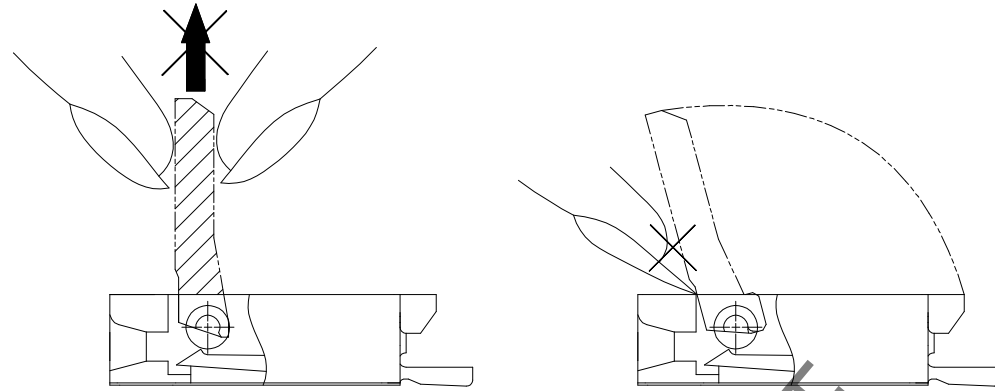

◆ Direction of Contacts

This connector has contacts on the bottom. Thus, insert FPC with the exposed conductors face down.

Inserting the FPC

1. Insert the FPC horizontally along the surface and at a right angle to the connector.
Insert it properly to the very end.
If the FPC is inserted at a slant (incorrectly) the conductors may short-circuit due to pitch shift or the edge of the FPC may catch in the terminals, resulting in deformation of the terminals.
This connector has a ZIF structure and its effective engagement length is 1.92mm (when the recommended FPC nominal is used)
Use the actuator carefully to prevent the FPC from dislocating after inserting it.

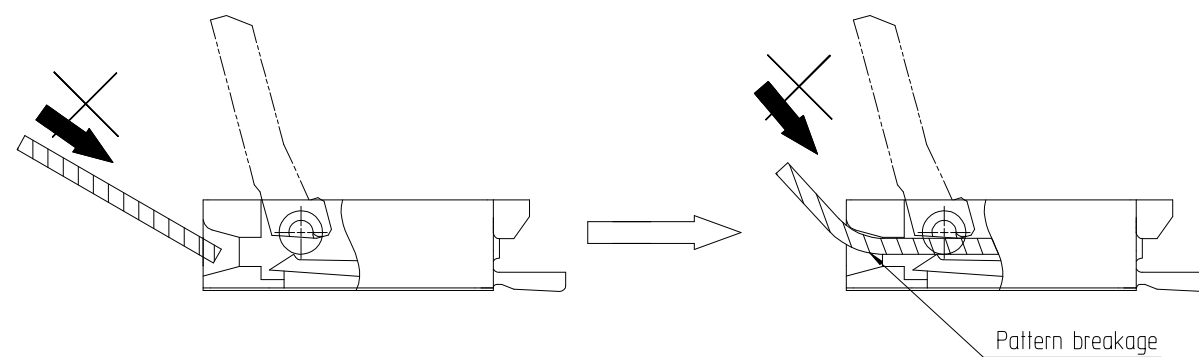

2. Do not insert the FPC diagonally from above
If the FPC is inserted at a slant (incorrectly) as shown below in the FPC insertion process, the FPC may bend and patterns may break or the FPC may not insert completely, resulting in improper conduction.
- # Keep a sufficient FPC insertion space in the stage of the layout in order to avoid incorrect FPC insertion. Besides, it is not difficult to insert FPC correctly at the way to the end. Designed the proper layout of parts.
 - # Make adjustments with the FPC manufacturer for bending performance and breakage resistant.

◆ Checking the Locking Condition

In the locked condition, make sure that actuator is horizontal on board surface.
Do not apply excessive force to it near the 0° position of the actuator.
Otherwise, the terminals may be deformed. (Allowable force: 1N or less)

[INSTRUCTION ON FPC LAYOUT AFTER CONNECTOR]

◆ Load to FPC

Be very careful not to apply any force to the FPC after inserting it. Otherwise, the connector may become unlocked or the FPC may break. Fix the FPC, in particular, when loads are applied to it continuously. Design the FPC layout with care not to bend it sharply near the insertion opening.

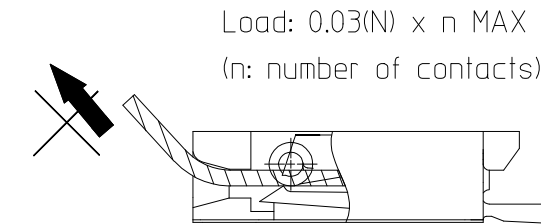

[INSTRUCTIONS ON REMOVING FPC]

- ◆ Release the actuator at approximately the center.
(It may break if operate the edge of the actuator with FPC inserted.)

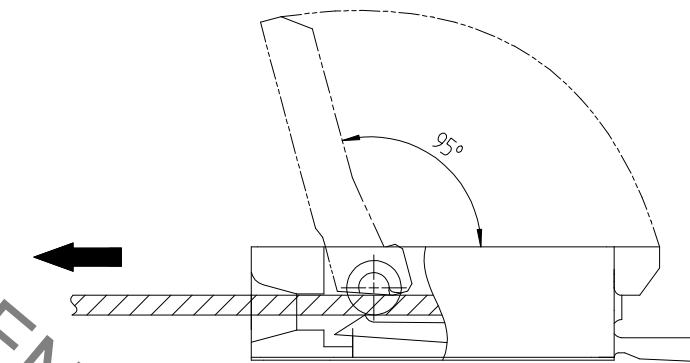

[OTHER INSTRUCTIONS]

◆ Instruction on Manual Soldering

- Follow the instructions shown when soldering the connector manually during repair work, etc
1. Do not perform reflow soldering or manual soldering with the FPC inserted into the connector.
 2. Do not heat the connector excessively. Be very careful not to let the soldering iron contact any parts other than connector leads. Otherwise, the connector may be deformed or melt.
 3. Do not use excessive solder (or flux)
if excessive solder (or flux) is used on the terminals, solder or flux may adhere to the contacts or rotating parts of the actuator, resulting in poor contact or a rotation failure of the actuator.