

May.1.2020 Copyright 2020 HIROSE ELECTRIC CO., LTD. All Rights Reserved.
 In case of consideration for using Automotive equipment / device which demand high reliability, kindly contact our sales window correspondents.

RECOMMENDED PANEL CUTOUT(4:1)

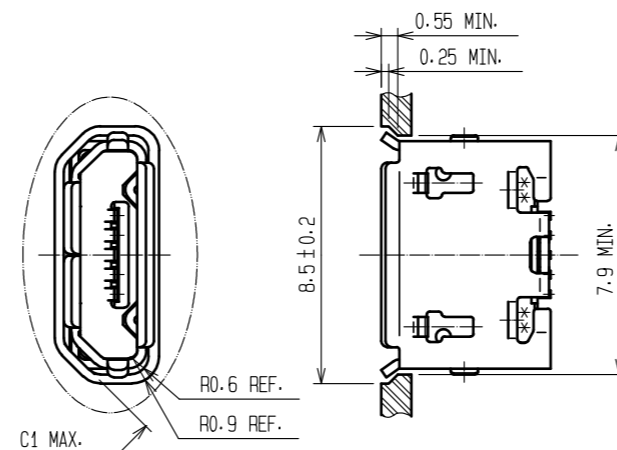

MATED WITH CORRESPONDING PLUG(4:1)

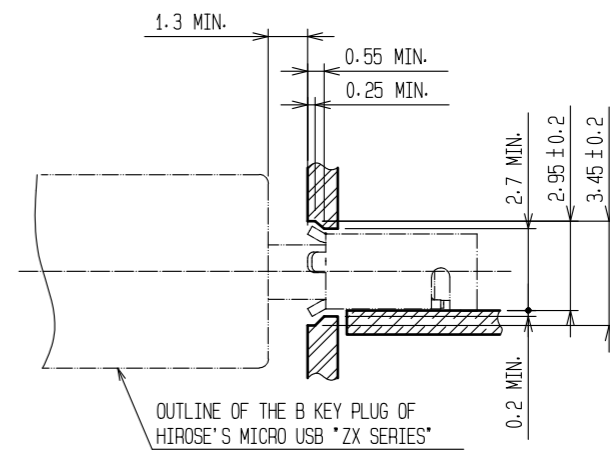

PCB LAYOUT

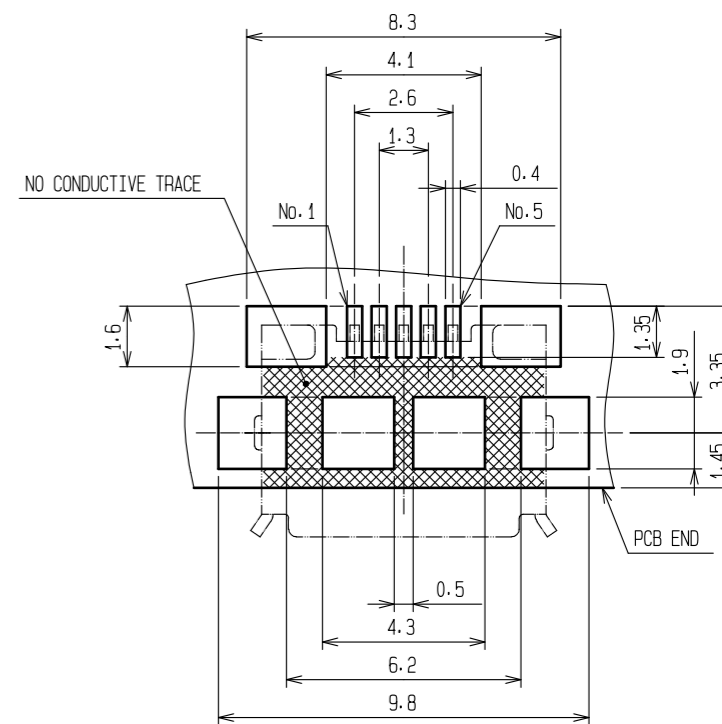

GENERAL TOLERANCE IS ±0.05mm.

- NOTES
- 1 CO-PLANARITY IS WITHIN 0.08 mm.
 - 2 PLATING
 CONTACT AREA : GOLD 0.75μm MIN.
 LEAD AREA : GOLD 0.05μm MIN.
 UNDER PLATING: NICKEL 2μm MIN.
 - 3 PER REEL : 3500 pcs.
 - 4. INTERFACE DIMENSIONS CONFORM TO USB2.0 SPECIFICATION.
 - 5. AS FOR PART No.3, THE PERFORMANCE REMAINS GOOD EVEN IF THERE ARE RUBBING WOUNDS BY THE ASSEMBLY PROCESS. AND, THE PERFORMANCE REMAINS GOOD THOUGH THERE MIGHT BE A DIFFERENCE IN THE PLATING LUSTER BETWEEN EACH PLATING SUBCONTRACT COMPANIES.
 - 6. AS FOR PART No.1, A PART OF SHAPE MAY BECOME DIFFERENT DEPENDING ON THE PRODUCTION METHOD.
 - 7 CODE CONFIGURATION IS SHOWN IN FIG.1.

| 2 | COPPER ALLOY | 2 | 5 | PE | | | | |
|-------------------------------|--------------|---------------------------|----------|------------------------------|--|----------|---------|------|
| 1 | LCP | BLACK, UL94V-0 | 4 | PS | | | | |
| | | | 3 | STAINLESS STEEL | OVER PLATING : TIN 1 μm min. LUBRICANT | | | |
| NO. | MATERIAL | FINISH . REMARKS | NO. | MATERIAL | FINISH . REMARKS | | | |
| UNITS | mm | SCALE | 5 : 1 | COUNT | DESCRIPTION OF REVISIONS | DESIGNED | CHECKED | DATE |
| HRS HIROSE ELECTRIC CO., LTD. | | APPROVED : NM. NISHIMATSU | 15.10.27 | DRAWING NO. EDC-126332-33-00 | | | | |
| | | CHECKED : KN. ICHIKAWA | 15.10.27 | PART NO. ZX62-B-5PA(33) | | | | |
| | | DESIGNED : TS. ITO | 15.10.27 | CODE NO. CL242-0033-8-33 | | | | |
| | | DRAWN : AK. AKIYAMA | 15.10.27 | | | | | |

May.1.2020 Copyright 2020 HIROSE ELECTRIC CO., LTD. All Rights Reserved.
In case of consideration for using Automotive equipment / device which demand high reliability, kindly contact our sales window correspondents.

3 DRAWING FOR PACKING

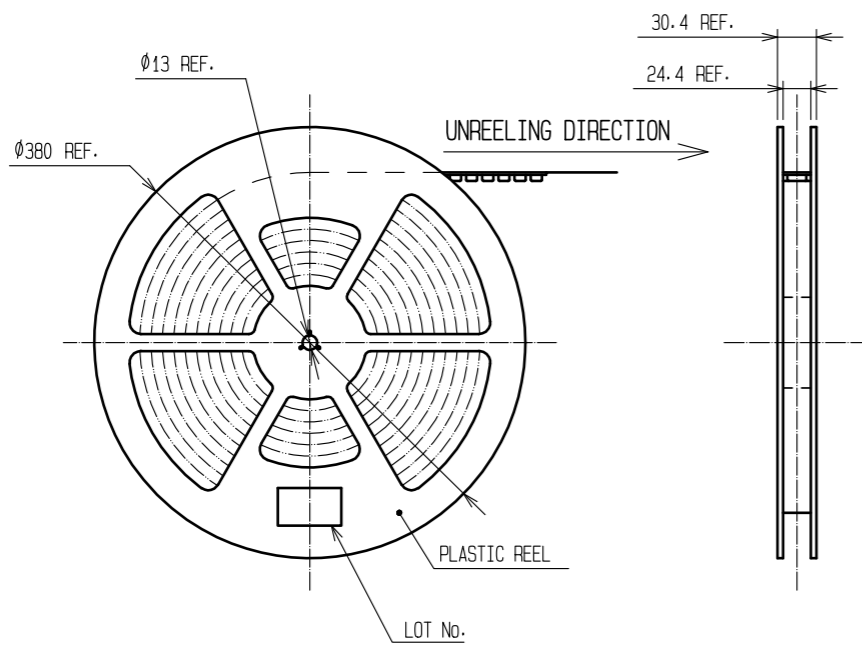
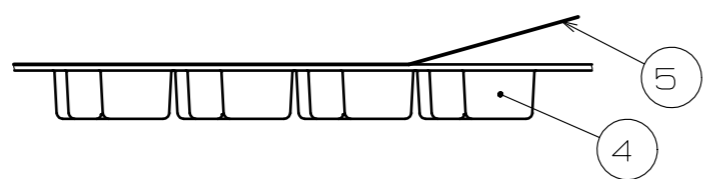
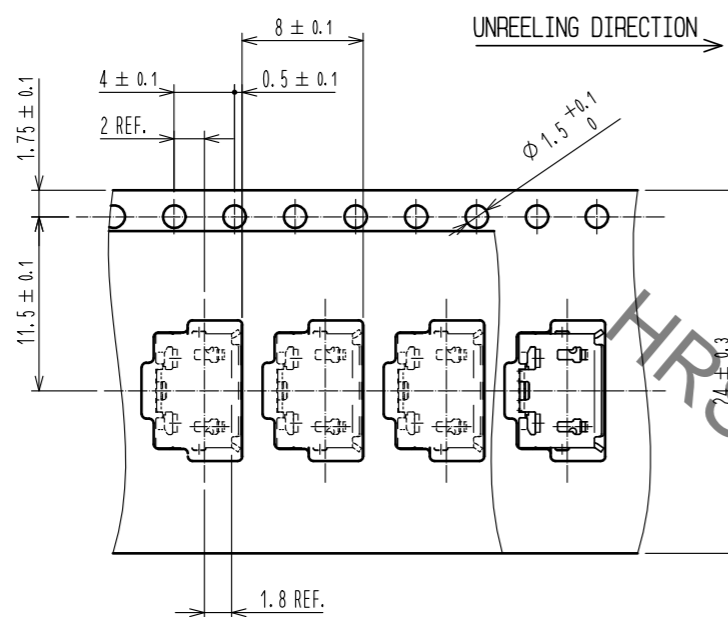

7 FIG.1 LOT CODE CONFIGURATION FOR 4 DIGITS

| YEAR | | MONTH | | DAY | | | | | | LINE No. | |
|------|------|-------|------|-----|------|-----|------|-----|------|----------|------|
| YEAR | CODE | MONTH | CODE | DAY | CODE | DAY | CODE | DAY | CODE | LINE No. | CODE |
| 2007 | 7 | Jan. | A | 1 | 1 | 11 | B | 21 | M | 1 | A |
| 2008 | 8 | Feb. | B | 2 | 2 | 12 | C | 22 | N | 2 | B |
| 2009 | 9 | Mar. | C | 3 | 3 | 13 | D | 23 | P | 3 | C |
| 2010 | 0 | Apr. | D | 4 | 4 | 14 | E | 24 | Q | 4 | D |
| 2011 | 1 | May. | E | 5 | 5 | 15 | F | 25 | R | 5 | E |
| | | Jun. | F | 6 | 6 | 16 | G | 26 | S | 6 | F |
| | | Jul. | G | 7 | 7 | 17 | H | 27 | T | 7 | G |
| | | Aug. | H | 8 | 8 | 18 | J | 28 | U | 8 | H |
| | | Sep. | I | 9 | 9 | 19 | K | 29 | V | 9 | I |
| | | Oct. | J | 10 | A | 20 | L | 30 | W | 10 | J |
| | | Nov. | K | | | | | 31 | X | 11 | K |
| | | Dec. | L | | | | | | | | |

HRS DRAWING FOR REFERENCE

| | | |
|------------|-------------|------------------|
| HRS | DRAWING NO. | EDC-126332-33-00 |
| | PART NO. | ZX62-B-5PA(33) |
| | CODE NO. | CL242-0033-8-33 |