

Hermaphroditic design means plugs will mate with an identical plug as well as receptacles. The removable insert assures correcting mating and alignment. In the Cannon FOMC, ruggedness is combined with good optical performance, rapid coupling and attractive pricing. Another feature for the FOMC design is the fiber flexure chamber which prevents tensile loads from being applied to the terminated fiber. The chamber provides space for surplus fiber in a service loop of sufficient length to permit one retermination of one or more fibers in the plug and cable receptacle without reterminating the strength member at the same time. This versatility is an ITT exclusive.

The FOMC 2, 4, and 8 channel connector are available as a cable plug, and several receptacle shell configurations. The 8 channel can also be used with less contacts i.e. 6,4, or 2 channels. Sealing plugs are supplied with the 8 channel connector when using less than the full complement of contacts. This catalog provides complete ordering information on available shell types, contact layouts, fiber and cable dimensional and mechanical parameters.

ITT's FOMC series fiber optic connectors are designed to meet the needs of military and commercial customers who require a rugged environmental multi-fiber field connector. The FOMC combines features which provide the user with a connector that will withstand rough handling and weather extremes with features of elastomeric cable and interface sealing, scoop proof interface to prevent optical contact damage, removable front insert for easy optical contact cleaning, anodized shell finish, and a tough, strong dust cap with attaching stainless steel strap.



## Standard Data

Description	Materials
Shell Hardware	Aluminum Alloy
Cable Clamp	Aluminum Alloy
Insert, Front Removable	Thermoplastic
Interfacial Seal	Elastomer
Cable Seal	Elastomer
O Rings	Elastomer
Alignment Guide	Thermoplastic
Strain Relief Spring	Stell wire with black chrome finish
Mandrel/Yoke	Thermoplastic
Receptacle Yoke	Thermoplastic
Dust Cap	Elastomer
Marking	Laser with clear chromate over exposed base metal

Fungus inert per requirement 4 of MIL-STD-454 Fluid resistant (elastomeric materials) per  
 MIL-H-5606-Hydraulic fluid, petroleum base  
 MIL-L-7808-Lubricating oil, synthetic base  
 MIL-G-3056-Gasoline  
 MIL-A-8243-Ethylene glycol

## Contact Arrangements

Face View of Insert

2 and 4 Channel

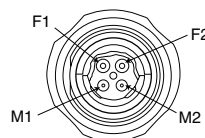
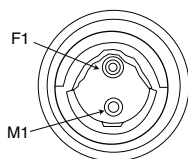

8 Channel

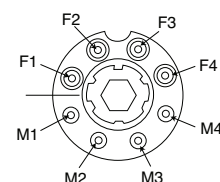

## How to Order

### SERIES

Fiber Optic Multi-Channel

### SHELL STYLE

2 - Square Flange Receptacle

(2/4 channel only)

6 - Cable Plug

7 - Jam Nut Receptacle

### SHELL SIZE (Channels)

(Maximum number of contact positions)

2

4

8

### DUST CAP

W - Connector supplied with dust cap

X - Without dust cap

### CABLE TYPE

1 - Pigtail buffered fiber (receptacle only)

2 - Multi fiber strengthened cable

3 - Singel fiber strengthened cables (8 channel only)

### SERIES

### SHELL STYLE

### SHELL SIZE

### DUST CAP

### CABLE TYPE

### CABLE SIZE (O.D)

### POLARIZATION POSITION

### MODIFICATION CODES

### CABLE SIZE (O.D)

A -  $.190 \pm .015$  (4.83  $\pm$  .38)

D -  $.236 \pm .019$  (6.0  $\pm$  .5)

F -  $.276 \pm .015$  (7.0  $\pm$  .4)

G -  $.374 \pm .015$  (9.50  $\pm$  .38)\*

H -  $.500 \pm .015$  (12.70  $\pm$  .38)\*

P - Pigtail buffered fiber

\*NOTE: Cable size G and H are for 8 channel FOMC Connector only

FOMC 6- 2 W 2 C \* \*\*\*

### POLARIZATION

(8 channel plug only. Omit for 2/4 channel)

0 - Not polarized

1 thru 6 - key position

### MODIFICATION CODES

Consult factory

## 2 and 4 Channel

### Square Flange Receptacle

FOMC 2

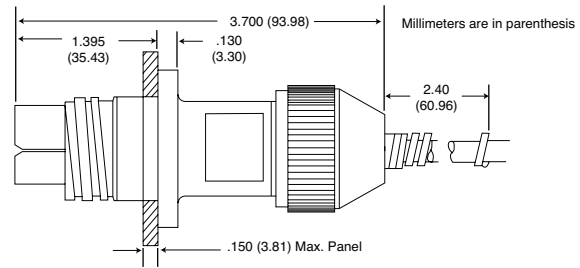
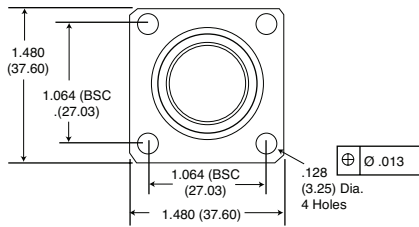

### Plug

FOMC 6

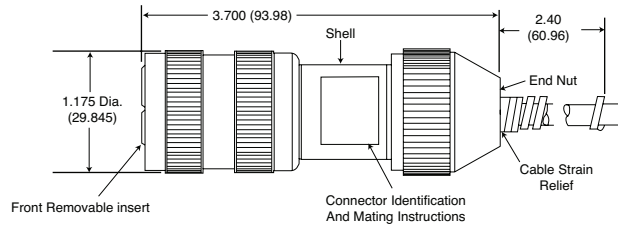
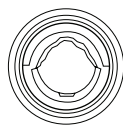

### Jam Nut Receptacle

FOMC 7

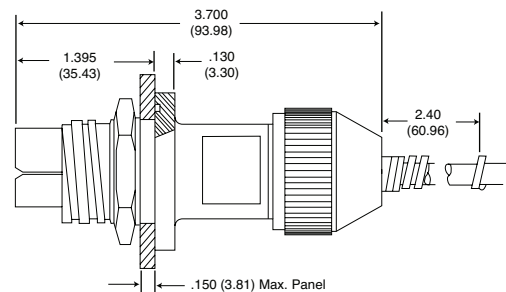
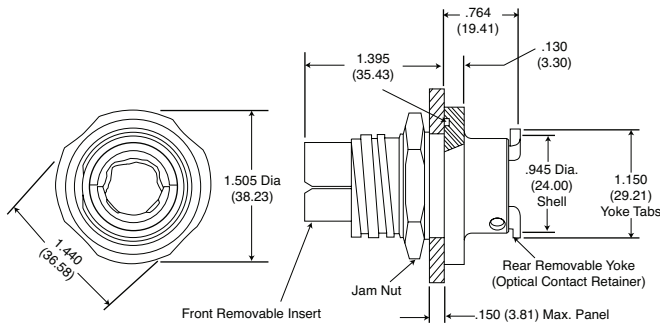

## 8 Channel

### Square Flange Receptacle

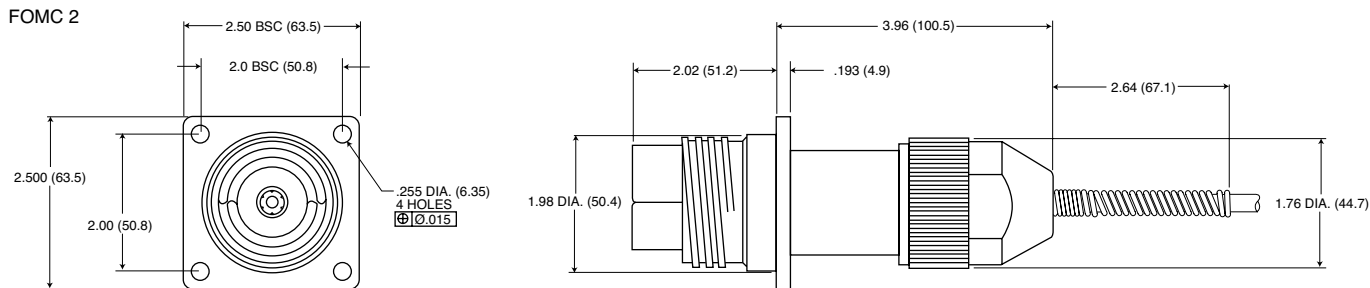

### Plug

#### FOMC 6

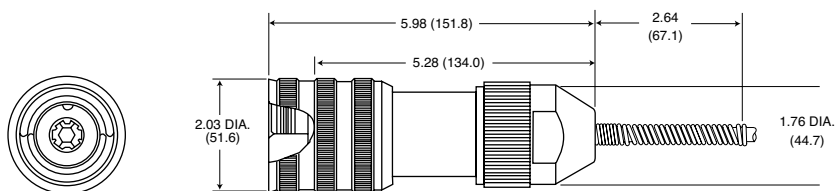

### Jam Nut Receptacle

#### FOMC 7

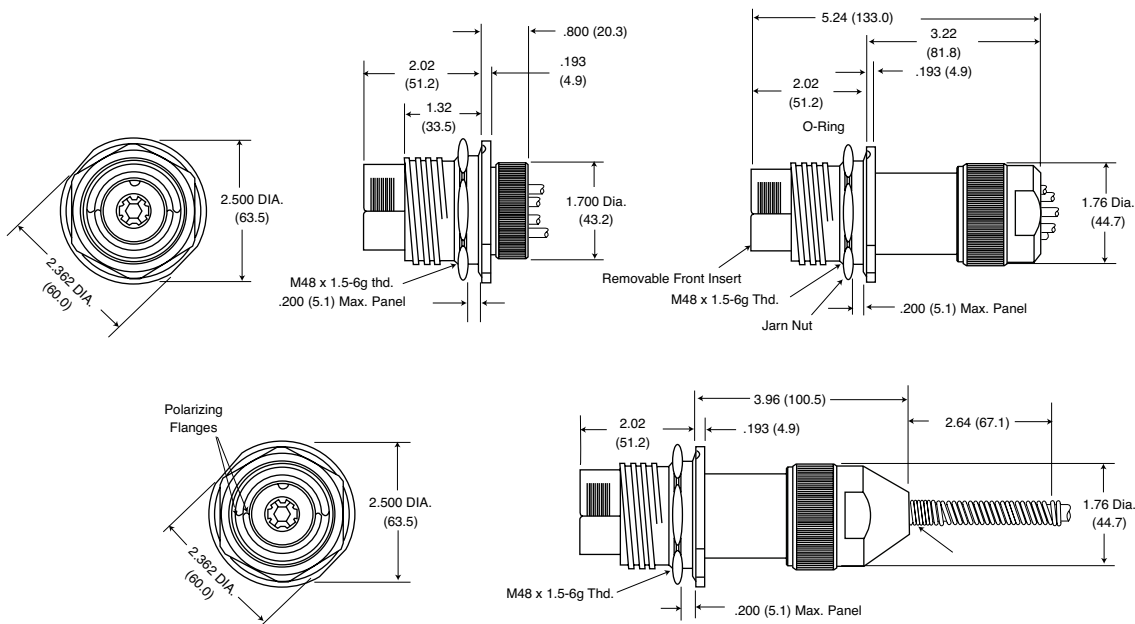

## Recommended Panel Cutouts

### 2 and 4 Channel

### 8 Channel

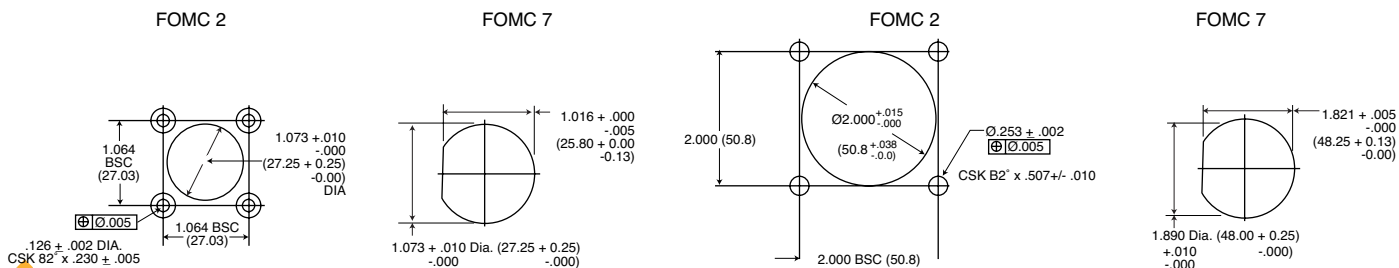

Contact Assembly

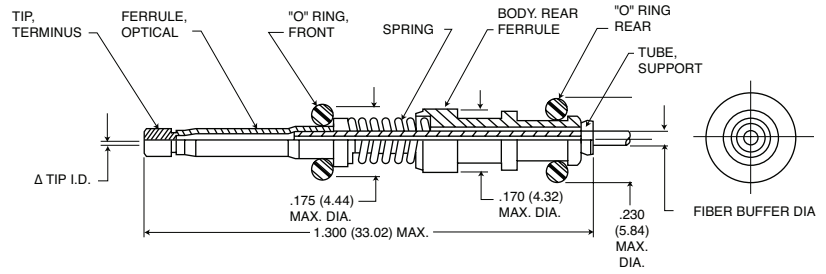

How to Order - Contacts

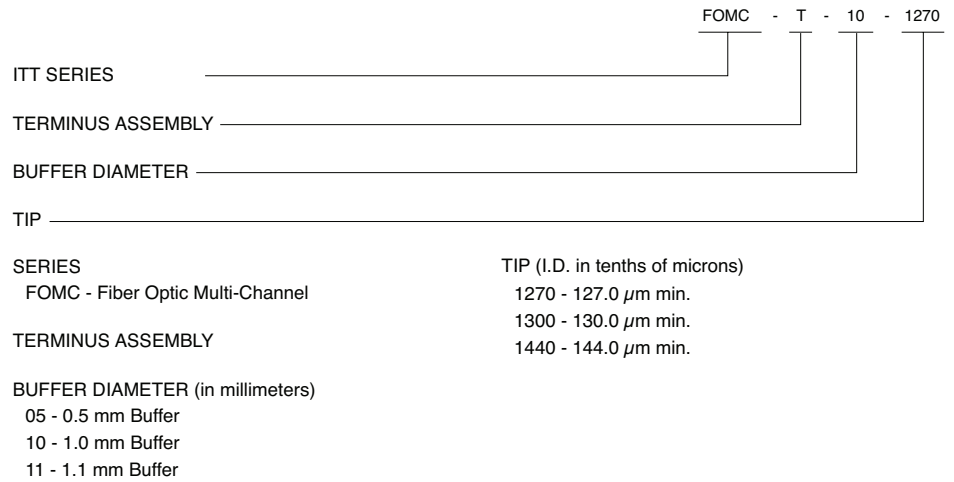

Coupling Performance

