

SJ112005

(ON DRAWING) 台架型図

版数 REV.	年月日 DATE	CN NO.	変更内容 DESCRIPTION	製図 DR.	担当 CHK.	査閲 APPD.	承認 APPD.
------------	-------------	--------	---------------------	-----------	------------	-------------	-------------

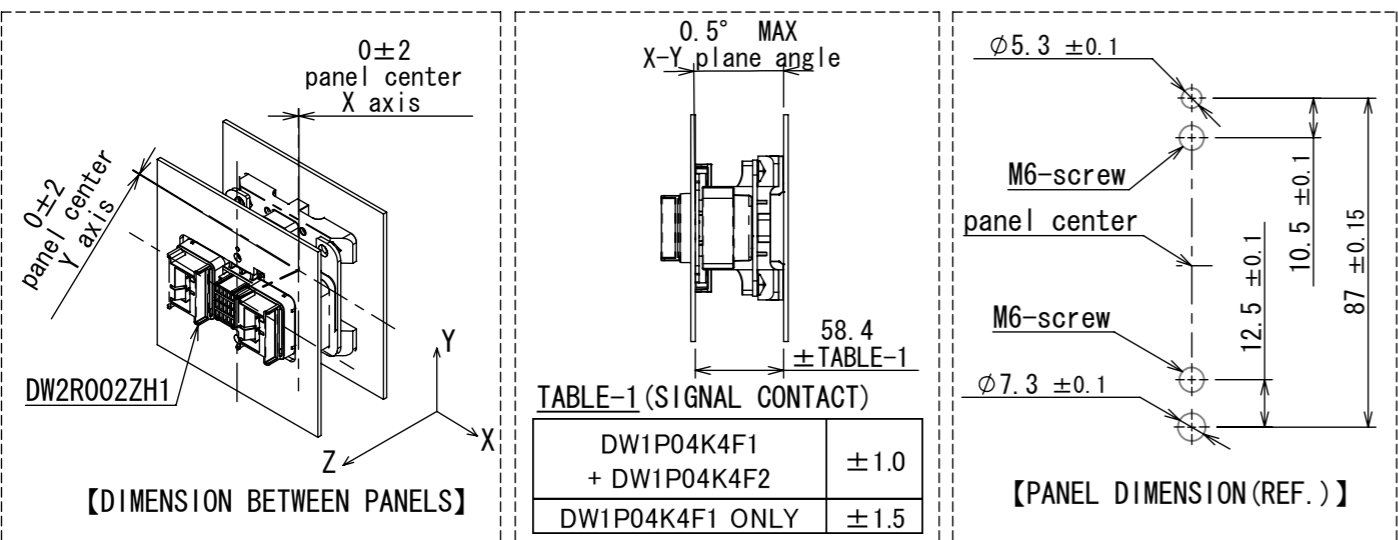

TABLE-1 (SIGNAL CONTACT)

DW1P04K4F1 + DW1P04K4F2	±1.0
DW1P04K4F1 ONLY	±1.5

特別管理品目
SPECIAL CONTROL ITEM
Li電池

Note 1. PRODUCTION LOT NUMBER AS INDICATED.
Note 2. TIGHTEN SCREW(M6) WITH 5.2[N·m]±0.3[N·m]
Note 3. TIGHTEN SCREW(M8) WITH 12.5[N·m]±0.75[N·m]
Note 4. HOLE FOR CABLE UNITY BAND.

注1. 図示の箇所にロットNo. を表示
(LOT MEMBER DISPLAY EXAMPLE ロット番号表示例)
J 1 1 Y 0 7
生産日 (DAY)
月 (10月:0, 11月:X, 12月:Y) (MONTH OCT:0, NOV:X, DEC:Y)
年 (西暦末尾) (YEAR LAST DIGIT ONLY)
製造コード (PRODUCT CODE)
注2. 本体ネジ (M6) 締付トルク 5.2[N·m]±0.3[N·m]
注3. 導電部ねじ (M8) 締付トルク 12.5[N·m]±0.75[N·m]
注4. ケーブル結束バンド用穴

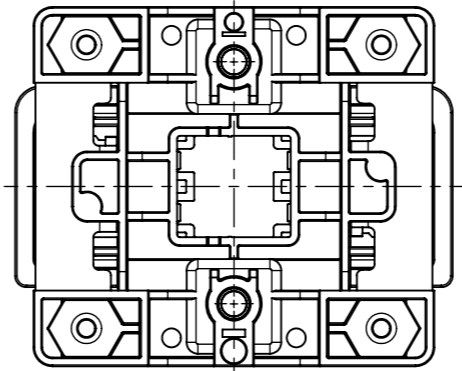
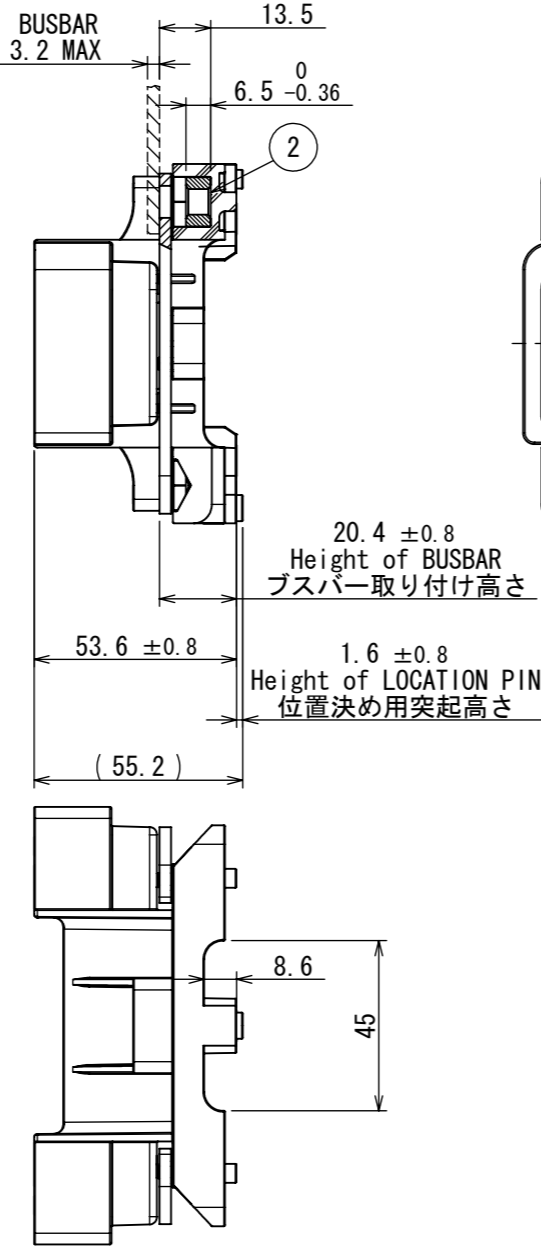
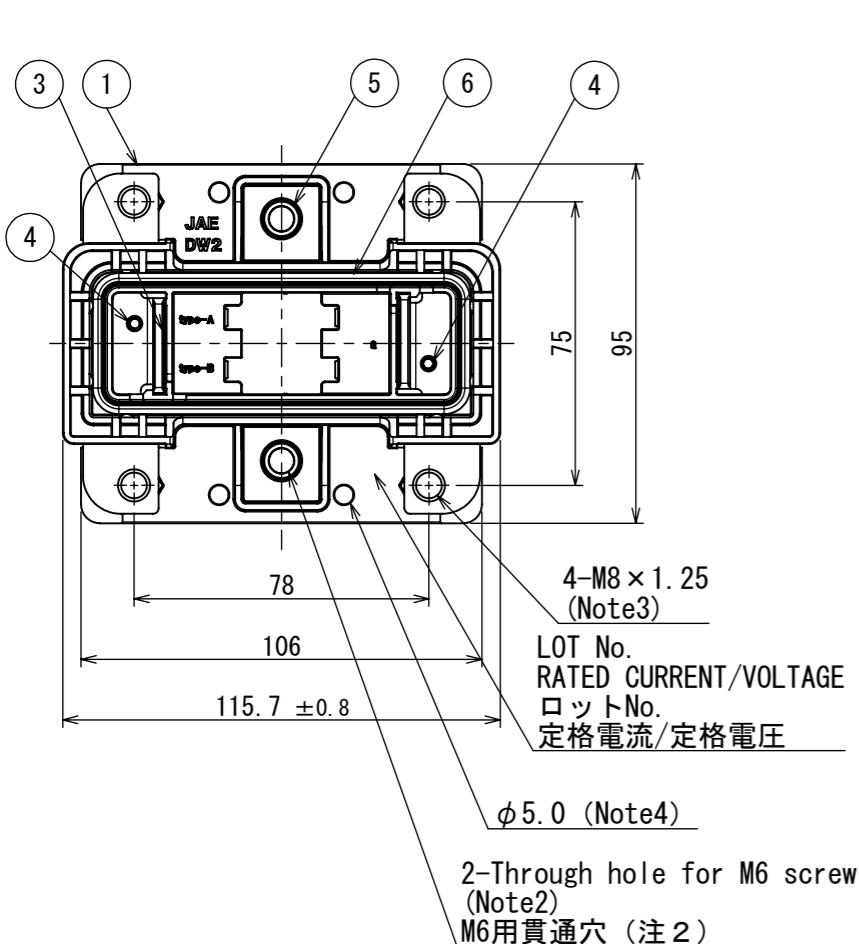

符号 NO.	名称 DESCRIPTION	個数 QTY.	材料 MATERIAL	仕上 FINISH	備考 REMARKS
6	GASKET	1	SILICON RUBBER	COLOR: GREY	
5	SLEEVE	2	BRASS	-	
4	SPRING PIN	2	STAINLESS STEEL	-	
3	PIN CONTACT	2	COPPER ALLOY	SILVER PLATING	
2	M8 HEXAGON NUT	4	BRASS	NICKEL PLATING	
1	OUTER HOUSING	1	PPS	COLOR: BLACK	

仕様書 (SPECIFICATION) JACS-30188 JAHL-30188	第1版 (ORIGINAL DATE) 16/DEC/2011	尺度 (SCALE) 1:2	シリーズ (SERIES) DW2	製図 (DR.) -	名称 (TITLE) DW2P002ZH1 (fixed connector)	製造会社 日本航空電子工業株式会社 JAE JAPAN AVIATION ELECTRONICS INDUSTRY, LTD.	図面番号 (DRAWING NO.) SJ112005	版数 (REV.) 1
一般公差 (GENERAL TOLERANCE) 寸法 (DIMENSION)	角度 (ANGLES)	担当 (CHK.) T. EBISAWA	査閲 (APPD.) Y. ITOU	承認 (APPD.) G. HAGA	質量 (MASS) -	図面番号 (DRAWING NO.) SJ112005		
. ±0.8	×° ±							
. × ±0.4	×°×' ±							
. ×× ±0.1								
. ××× ±								

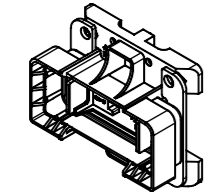

【perspective view】

DCF-C-212G (11.08)

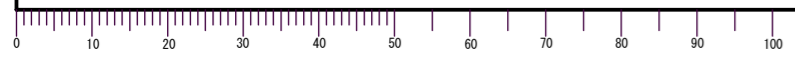

WISDOM承認 2012/01/05