

SJ112006  
(DRAWING NO.)

版数 REV.	年月日 DATE	CN NO.	変更内容 DESCRIPTION	製図 DR.	担当 CHK.	査閲 APPD.	承認 APPD.
------------	-------------	--------	---------------------	-----------	------------	-------------	-------------

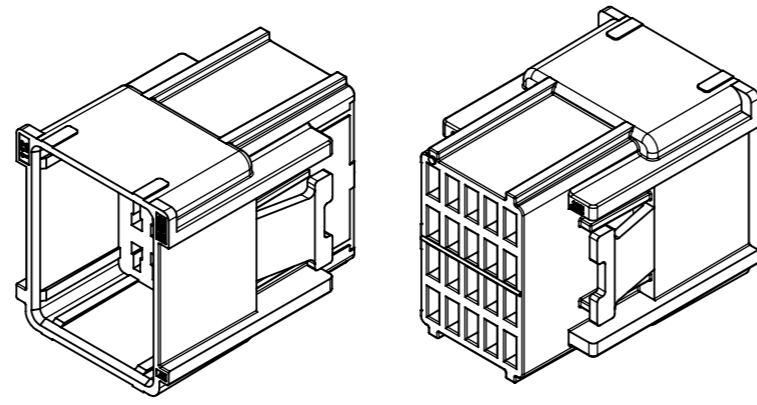
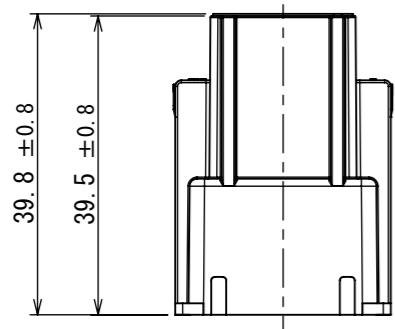

【perspective view】

**特別管理品目**  
SPECIAL CONTROL ITEM  
**Li電池**

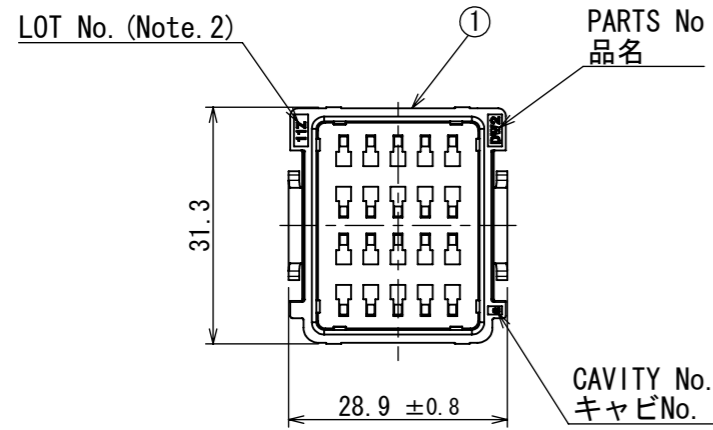

DW2R0101 MATING SIDE  
(Housing-A)

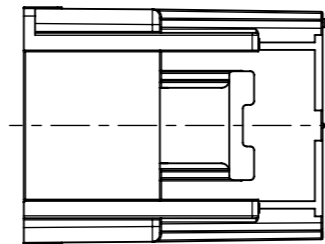

DW2R0102 MATING SIDE  
(Housing-B)

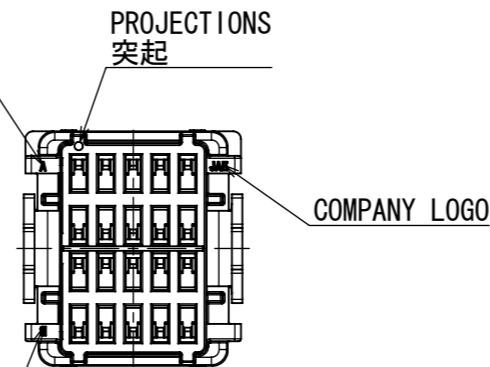

Table-1

Contact Part No	Size	Outer Diameter	Remarks
DW1P04K4F1 (SJ111311)	AWG#22	φ 1.5	Signal Contact
DW1P04K4F2 (SJ111312)	AWG#22	φ 1.5	Detected Contact

Note 1. CONTACTS ARE SOLD SEPARATELY. THE APPLICABLE CONTACTS ARE LISTED IN THE TABLE-1.  
Note 2. YEAR AND MONTH OF MANUFACTURED SHALL BE SHOWN AT THE LOCATION.  
(LEFT:ONE LAST DIGIT OF YEAR, RIGHT:MONTH 123456789XYZ)

注1. 本製品はコンタクト別売品であり、適用コンタクトは表1のとおりである。  
注2. 図示の位置に製造年月を表示する。  
(左側：西暦3桁、4桁、右側：月123456789XYZ)

1	INNER HOUSING	1	PBT	COLOR: BLACK	
符号 NO.	名称 DESCRIPTION	個数 QTY.	材料 MATERIAL	仕上 FINISH	備考 REMARKS

仕様書 (SPECIFICATION) JACS-30188 JAHL-30188		第1版 (ORIGINAL DATE) 16/DEC/2011		尺度 (SCALE) 1:1	シリーズ (SERIES) DW2	日本航空電子工業株式会社
一般公差 (GENERAL TOLERANCE)		製図 DR.		名称 (TITLE) DW2P020 (Floating connector inner Housing)		JAE JAPAN AVIATION ELECTRONICS INDUSTRY, LTD.
寸法 (DIMENSION)		担当 CHK. Y. EBISAWA		質量 (MASS)		
角度 (ANGLES)		査閲 APPD. Y. ITOU		図面番号 (DRAWING NO.) SJ112006		版数 (REV.) 1
. ± 0.8		承認 APPD. G. HAGA				
. X ± 0.4						
. XX ± 0.1						
. XXX ±						

DCF-C-212G (11.08)

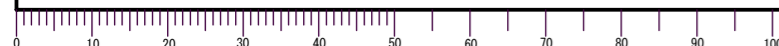

S/W

WISDOM承認 2012/01/05