

NEW



DW2 Series

(UL Recognized Product)

CONNECTOR
MB-0266-1
January 2014

RoHS Compliant

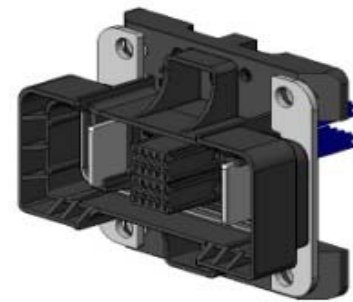
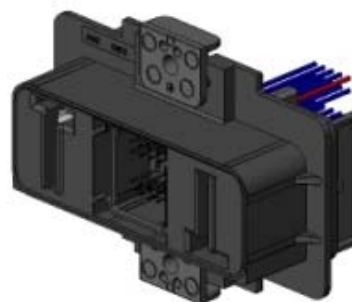
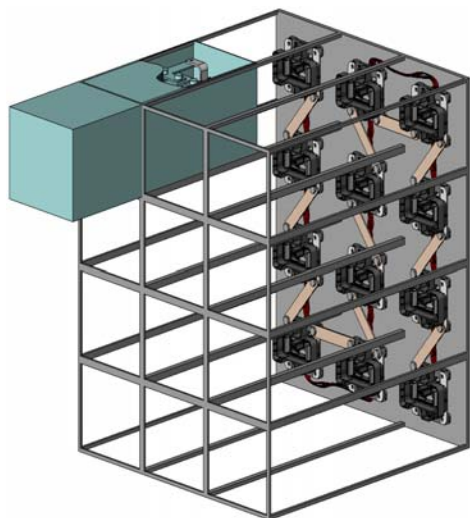

Drawing when DW2 is mounted

Receptacle (DW2R002ZH1)

Plug (DW2P002ZH1)

<<Out Line>>

The DW2 Series is a rack and panel connector with 2 contacts for high-current (200A). It enables the connection of the 2 contacts for power supply and 20 contacts for signal at once. The DW2 Series is suitable for use in a wide range of applications such as storage battery systems, power supply systems, UPS, and other power supply control equipments. The DW2 Series is a UL recognized product.

Features

- UL Recognized Product: File No.E67741 
- High-current: compatible with 200A
- Electrical Shock Prevention: structure that prevents a person's fingers from touching the terminals on receptacle side.
- Floating Amount: $\pm 2.75\text{mm}$
- Robust housing integrating complex power supply and signal area.
- Signal connector can be attached to the main unit using an exclusive jig.
- Signal area has a 2-point contacting structure contact.
- Connection of receptacle side power supply can be made at once using the bus bar.

General Specifications

- No. of Contacts:
 - 2 pos. (power supply)
 - 20 pos. (signal)
- Rated Current:
 - 200A (power supply)
 - 2A (signal)
- Rated Voltage :
 - 600V (power supply) * Note 1
 - 100V (signal)
- Contact Resistance:
 - 0.2m Ω max. (initial) power supply
 - 20m Ω max. (initial) signal
- Durability: 100 times
- Operating Temperature:
 - 25 Deg. C ~ +115 Deg. C
- Wire Size: 22AWG, twisted wire with insulation cover outer diameter 1.5mm Dia. (signal)

Note 1: Please contact us when considering use in usage environments that exceed 600V.

Ordering Information

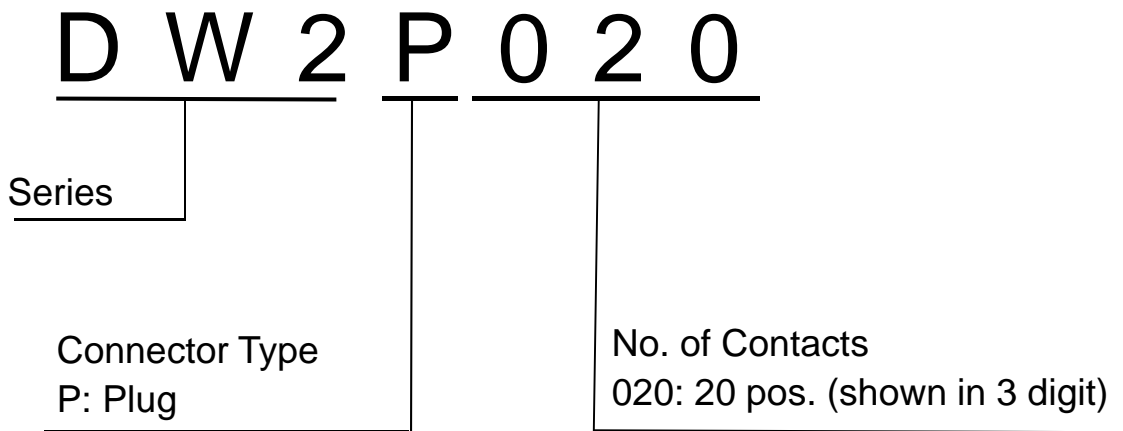
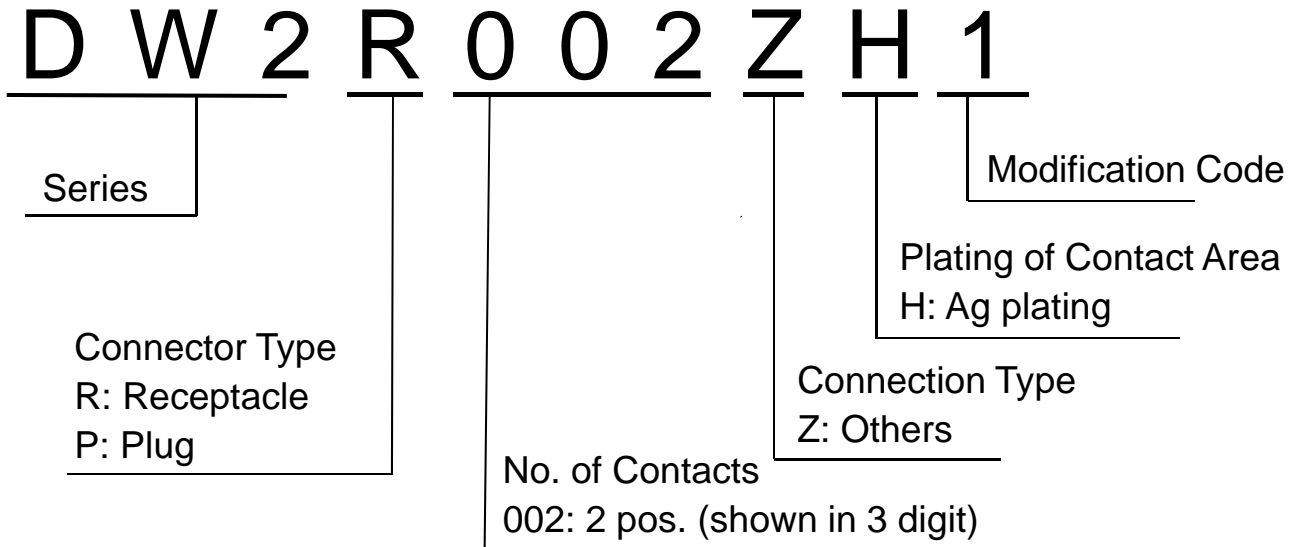

Ordering Information

D W 2 R 0 1 0 1

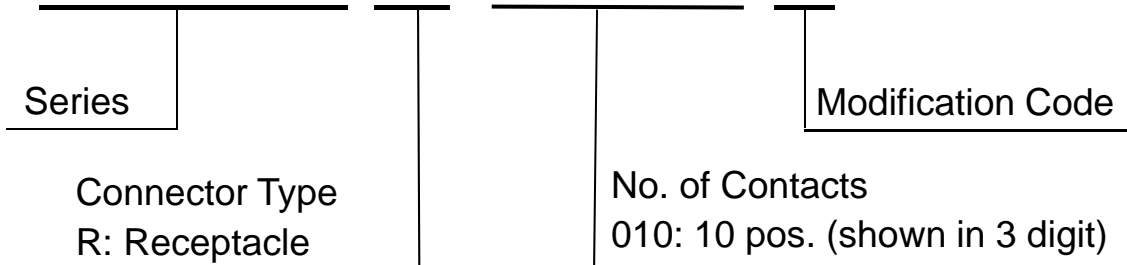

D W 1 S 0 4 K 4 F 1

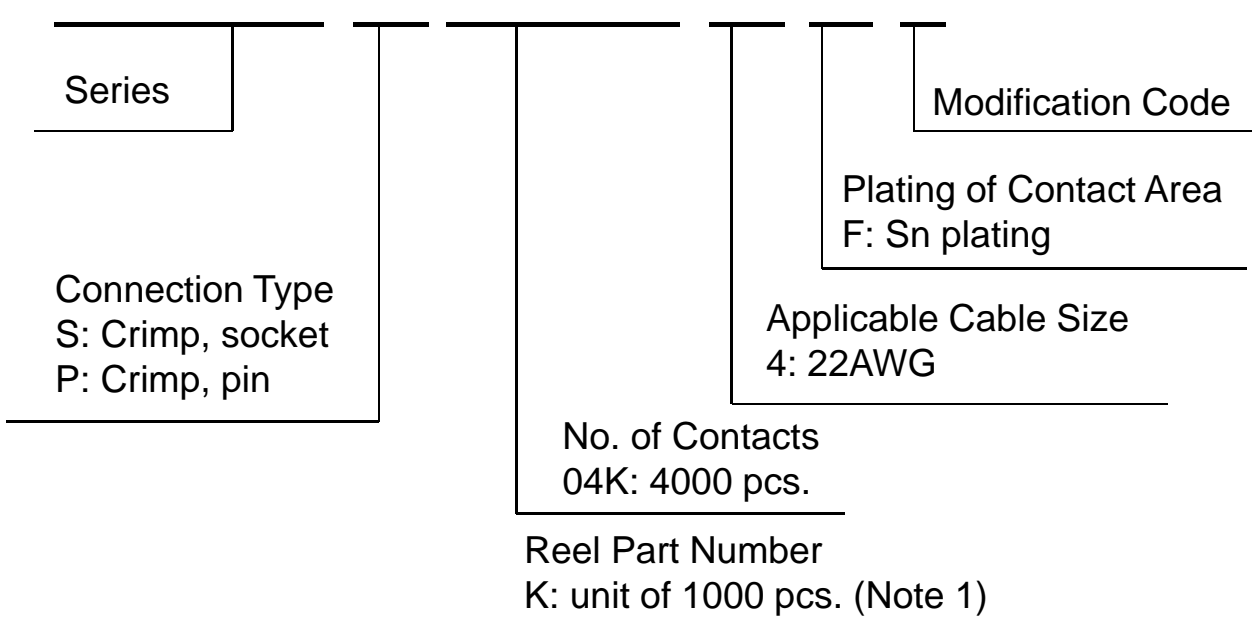

Note 1: An embossed reel contains 4,000 pcs.

Product Drawing

1. Receptacle (Main Unit)

Part Number	DW2R002ZH1
SJ Drawing	SJ112004

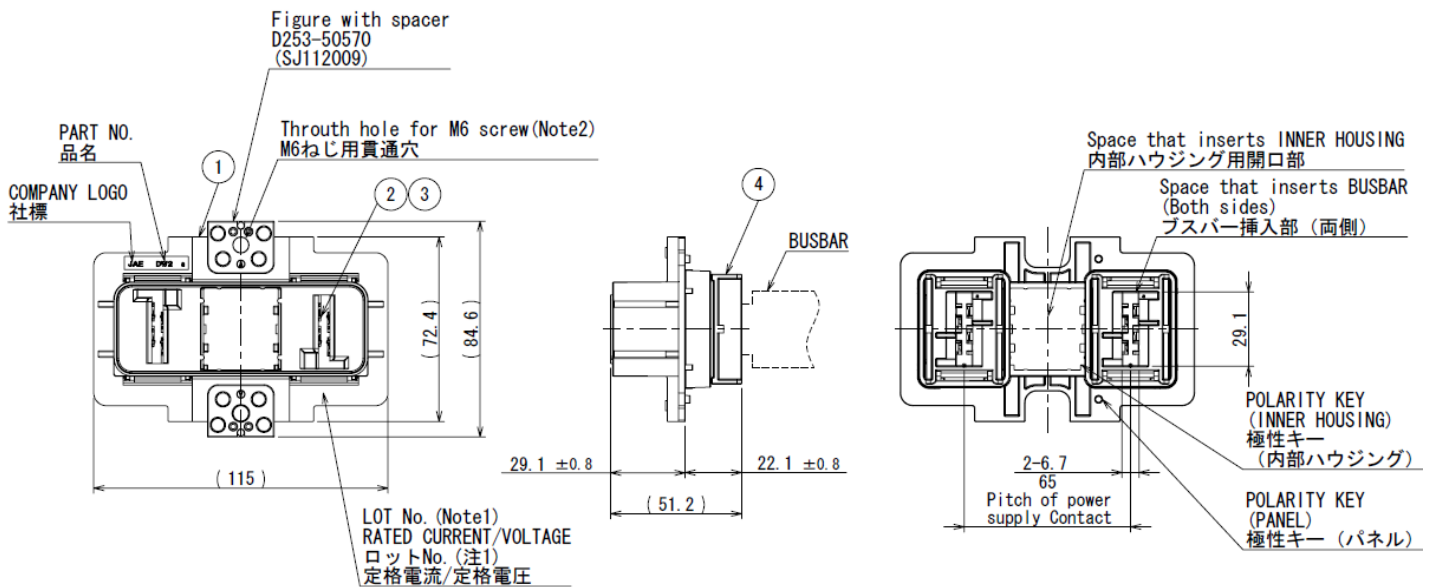

- Note 1. PRODUCTION LOT NUMBER AS INDICATED.
 Note 2. TIGHTEN SCREW (M6) WITH 5.2 [N · m] ± 0.3 [N · m]
 SIZE OF MALE SCREW RIDGE : φ5.82 ~ φ5.97
 Note 3. DON'T PUT THE FOREIGN BODY WITHIN THIS RANGE.

- 注1. 図示の箇所にロットNo. を表示
 (LOT NUMBER DISPLAY EXAMPLE ロット番号表示例)
 J 1 1 Y 0 7
 生産日 (DAY)
 月 (10月:0, 11月:X, 12月:Y) (MONTH OCT:0, NOV:X, DEC:Y)
 年 (西暦末尾) (YEAR LAST DIGIT ONLY)
 製造コード (PRODUCT CODE)
- 注2. 本体ネジ (M6) 締付トルク 5.2 [N · m] ± 0.3 [N · m]
 ねじ山寸法 : φ5.82 ~ φ5.97
 注3. この範囲に異物を設けないこと。

4	REAR HOUSING	2	PBT	COLOR: BLACK	
3	HELICAL EXTENSION SPRING	4	STAINLESS STEEL	-	
2	FLOATING CONTACT	8	COPPER ALLOY	SILVER PLATING	
1	OUTER HOUSING	1	PPS	COLOR: BLACK	
符号 NO.	名称 DESCRIPTION	個数 QTY.	材料 MATERIAL	仕上 FINISH	備考 REMARKS

2. Plug (Main Unit)

Part Number	DW2P002ZH1
SJ Drawing	SJ112005

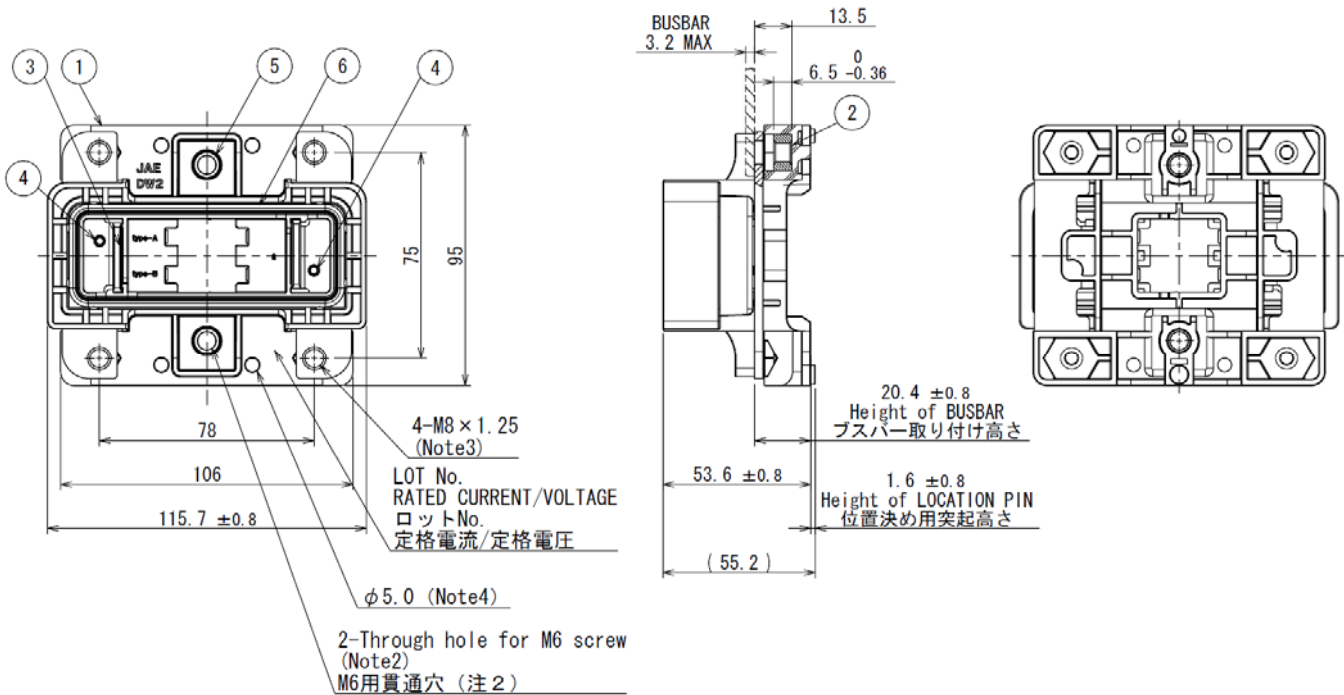

- Note 1. PRODUCTION LOT NUMBER AS INDICATED.
- Note 2. TIGHTEN SCREW (M6) WITH 5.2 [N · m] ± 0.3 [N · m]
- Note 3. TIGHTEN SCREW (M8) WITH 12.5 [N · m] ± 0.75 [N · m]
- Note 4. HOLE FOR CABLE UNITY BAND.

注 1. 図示の箇所にロットNo. を表示
(LOT NUMBER DISPLAY EXAMPLE ロット番号表示例)

J 1 1 Y 0 7

- 生産日 (DAY)
- 月 (10月:0, 11月:X, 12月:Y) (MONTH OCT:0, NOV:X, DEC:Y)
- 年 (西暦末尾) (YEAR LAST DIGIT ONLY)
- 製造コード (PRODUCT CODE)

- 注 2. 本体ネジ (M6) 締付トルク 5.2 [N · m] ± 0.3 [N · m]
- 注 3. 導電部ねじ (M8) 締付トルク 12.5 [N · m] ± 0.75 [N · m]
- 注 4. ケーブル結束バンド用穴

符号 No.	名称 DESCRIPTION	個数 QTY.	材料 MATERIAL	仕上 FINISH	備考 REMARKS
6	GASKET	1	SILICON RUBBER	COLOR: GREY	
5	SLEEVE	2	BRASS	-	
4	SPRING PIN	2	STAINLESS STEEL	-	
3	PIN CONTACT	2	COPPER ALLOY	SILVER PLATING	
2	M8 HEXAGON NUT	4	BRASS	NICKEL PLATING	
1	OUTER HOUSING	1	PPS	COLOR: BLACK	

3. Connector for Signal (Receptacle Side)

Part Number	DW2P020
SJ Drawing	SJ112006

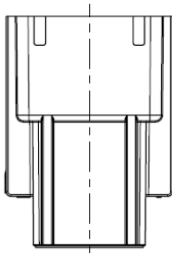
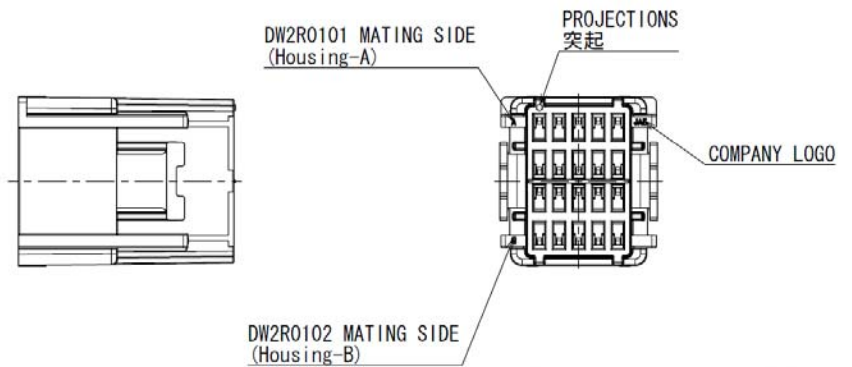
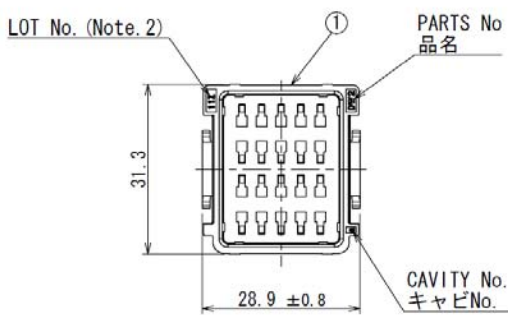
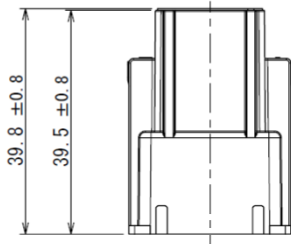

Table-1

Contact Part No	Size	Outer Diameter	Remarks
DW1P04K4F1 (SJ111311)	AWG#22	φ 1.5	Signal Contact
DW1P04K4F2 (SJ111312)	AWG#22	φ 1.5	Detected Contact

Note 1. CONTACTS ARE SOLD SEPARATELY. THE APPLICABLE CONTACTS ARE LISTED IN THE TABLE-1.

Note 2. YEAR AND MONTH OF MANUFACTURED SHALL BE SHOWN AT THE LOCATION.
(LEFT:ONE LAST DIGIT OF YEAR, RIGHT:MONTH 123456789XYZ)

注 1. 本製品はコンタクト別売品であり、適用コンタクトは表 1 のとおりである。

注 2. 図示の位置に製造年月を表示する。
(左側：西暦 3 桁、4 桁、右側：月 123456789XYZ)

1	INNER HOUSING	1	PBT	COLOR: BLACK	
符号 NO.	名 称 DESCRIPTION	個 数 QTY.	材 料 MATERIAL	仕 上 FINISH	備 考 REMARKS

4. Connector A for Signal (Plug Side)

Part Number	DW2R0101
SJ Drawing	SJ112007

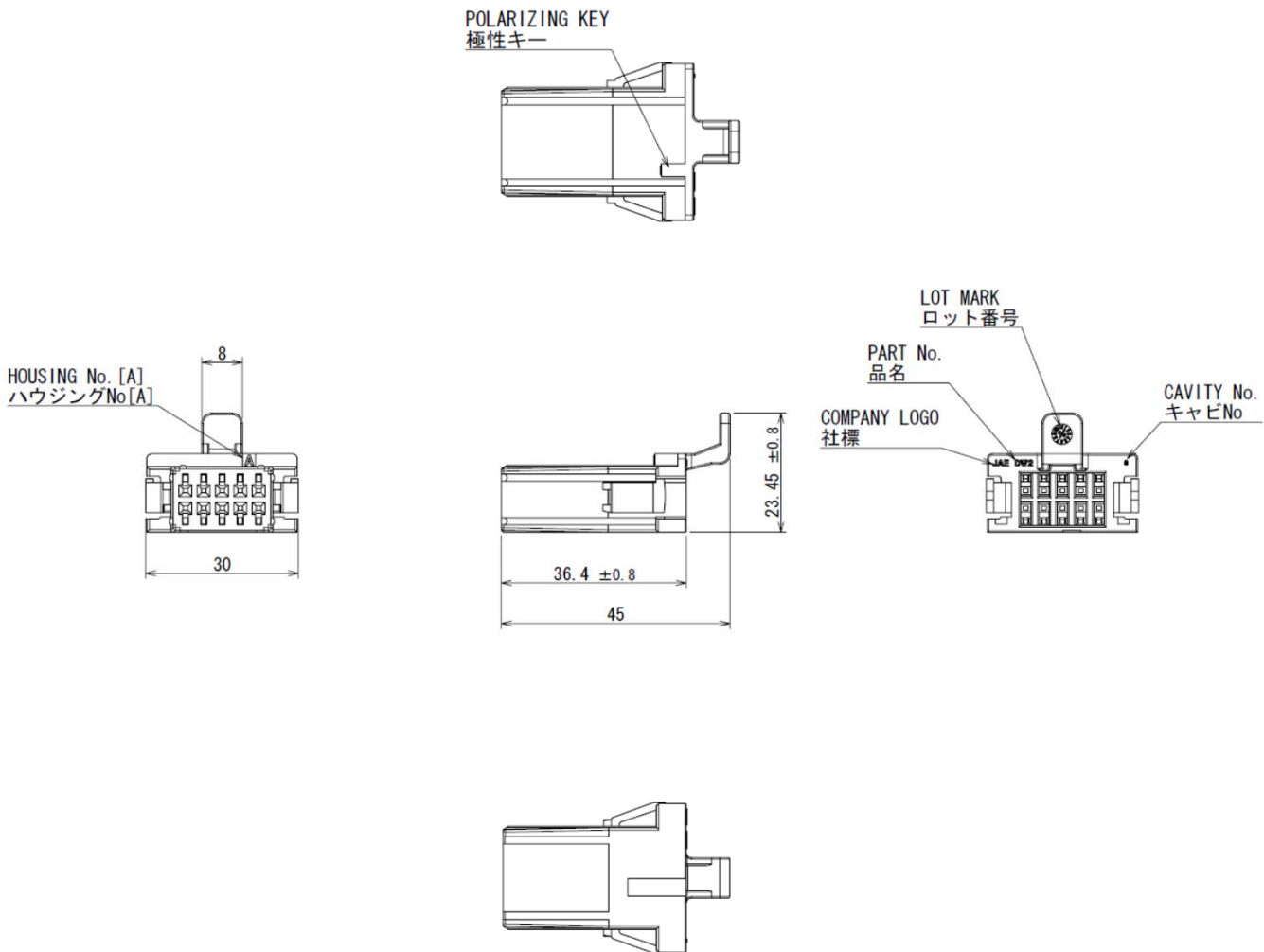

Table-1

Contact Part No	Size	Outer Diameter	Remarks
DW1S04K4F1 (SJ111310)	AWG#22	φ 1.5	Signal Contact

Note 1. CONTACTS ARE SOLD SEPARATELY. THE APPLICABLE CONTACTS ARE LISTED IN THE TABLE-1.
 Note 2. THE POSITION OF THE POLARITY KEY IS DIFFERENT COMPARED WITH THE FOLLOWING PARTS.
 DW2R0102 (SJ112008)

注 1. 本製品はコンタクト別売品であり、適用コンタクトは表 1 のとおりである。
 注 2. 本製品は下記品目と極性キー位置違い品である。
 DW2R0102 (SJ112008)

1	INNER HOUSING -A	1	PBT	COLOR: BLACK	
符号 NO.	名 称 DESCRIPTION	個 数 QTY.	材 料 MATERIAL	仕 上 FINISH	備 考 REMARKS

5. Connector B for Signal (Plug Side)

Part Number	DW2R0102
SJ Drawing	SJ112008

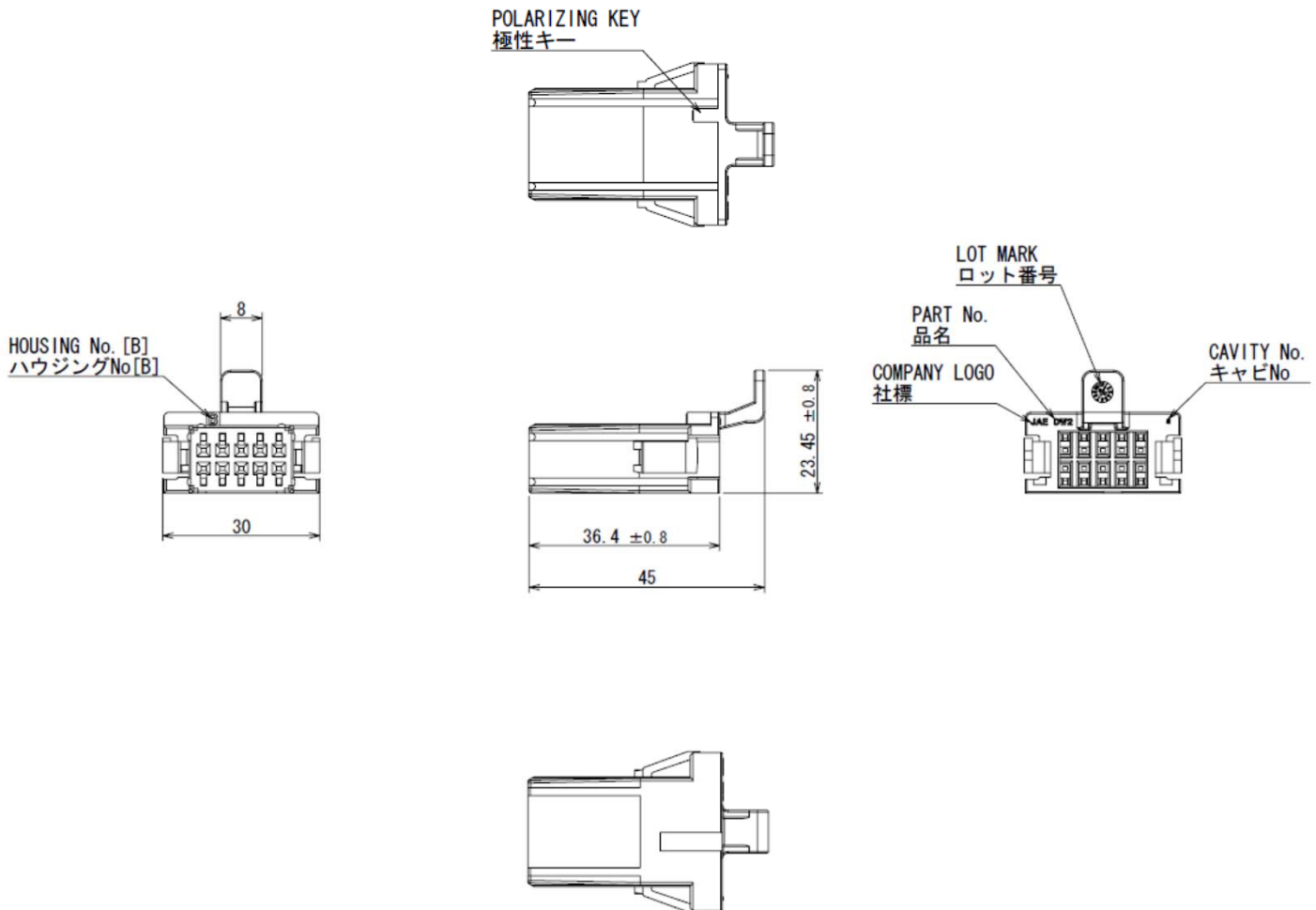

Table-1

Contact Part No	Size	Outer Diameter	Remarks
DW1S04K4F1 (SJ111310)	AWG#22	φ 1.5	Signal Contact

Note 1. CONTACTS ARE SOLD SEPARATELY. THE APPLICABLE CONTACTS ARE LISTED IN THE TABLE-1.
 Note 2. THE POSITION OF THE POLARITY KEY IS DIFFERENT COMPARED WITH THE FOLLOWING PARTS.
 DW2R0101 (SJ112007)

注 1. 本製品はコンタクト別売品であり、適用コンタクトは表 1 のとおりである。
 注 2. 本製品は下記品目と極性キー位置違い品である。
 DW2R0101 (SJ112007)

1	INNER HOUSING -B	1	PBT	COLOR: BLACK	
符号 NO.	名 称 DESCRIPTION	個 数 QTY.	材 料 MATERIAL	仕 上 FINISH	備 考 REMARKS

6. Spacer

Part Number	D253-50570
SJ Drawing	SJ112009

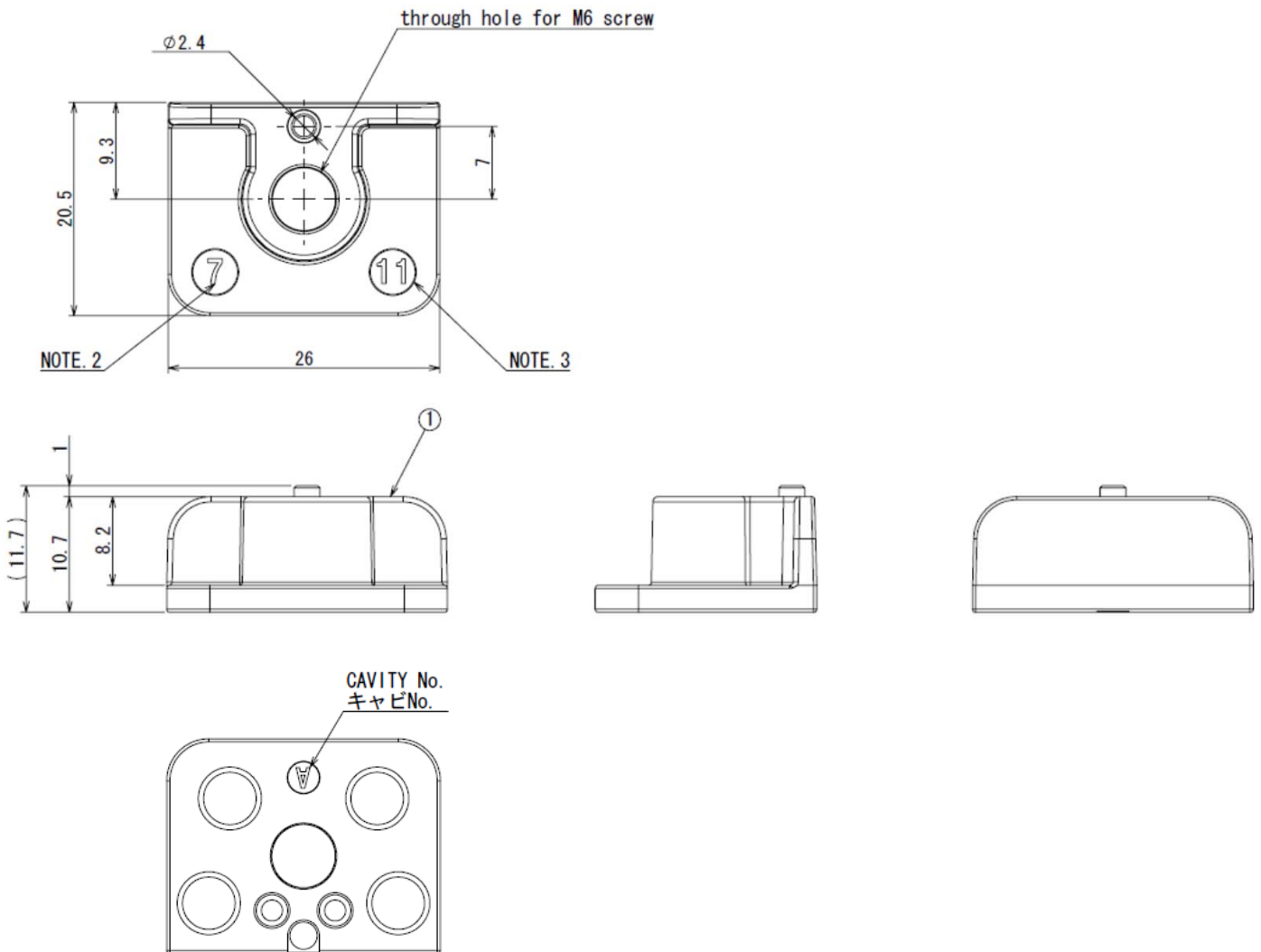

NOTE 1. This product is an optional spacer of DW2R002ZH1.

NOTE 2. Month of manufacture.

NOTE 3. Year of manufacture.

注1. 本製品はDW2R002ZH1の別売スペーサである。

注2. 製造年

注3. 製造月

1	Spacer	1	Zinc alloy	Nickel Plating over Copper	
符号 NO.	名 称 DESCRIPTION	個 数 QTY.	材 料 MATERIAL	仕 上 FINISH	備 考 REMARKS

7. Socket Contact for Signal (for Plug)

Part Number	DW1S04K4F1
SJ Drawing	SJ111310

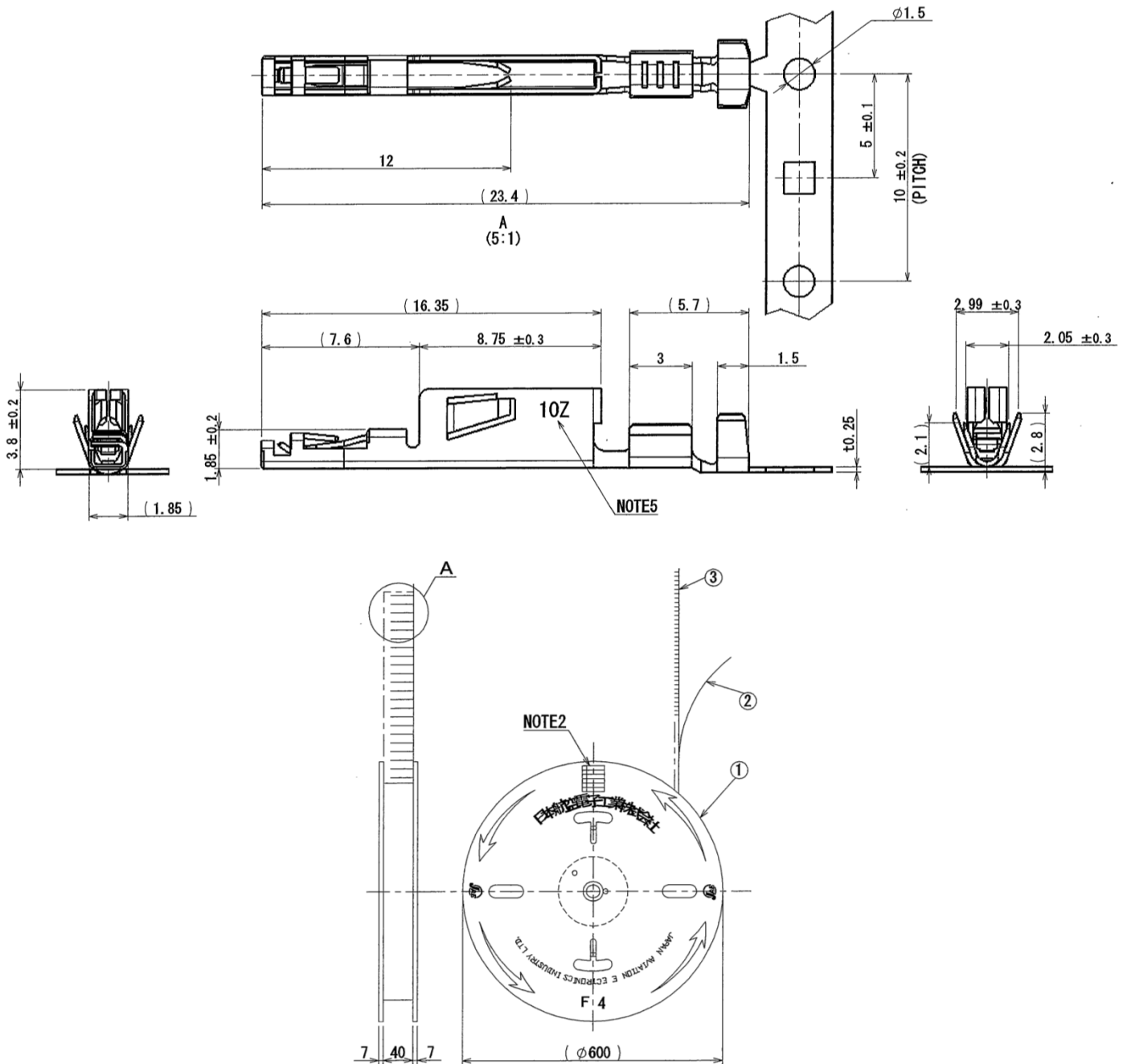

符号 NO.	名称 DESCRIPTION	数量 QTY.	材料 MATERIAL	仕上 FINISH	備考 REMARKS
3	SOCKET CONTACT	4000	COPPER ALLOY	TIN PLATE	—
2	PAPER TAPE	1	PAPER	—	—
1	MAGAZINE	1	PAPER	—	—

8. Pin Contact Long for Signal (for Receptacle)

Part Number	DW1P04K4F1
SJ Drawing	SJ111311

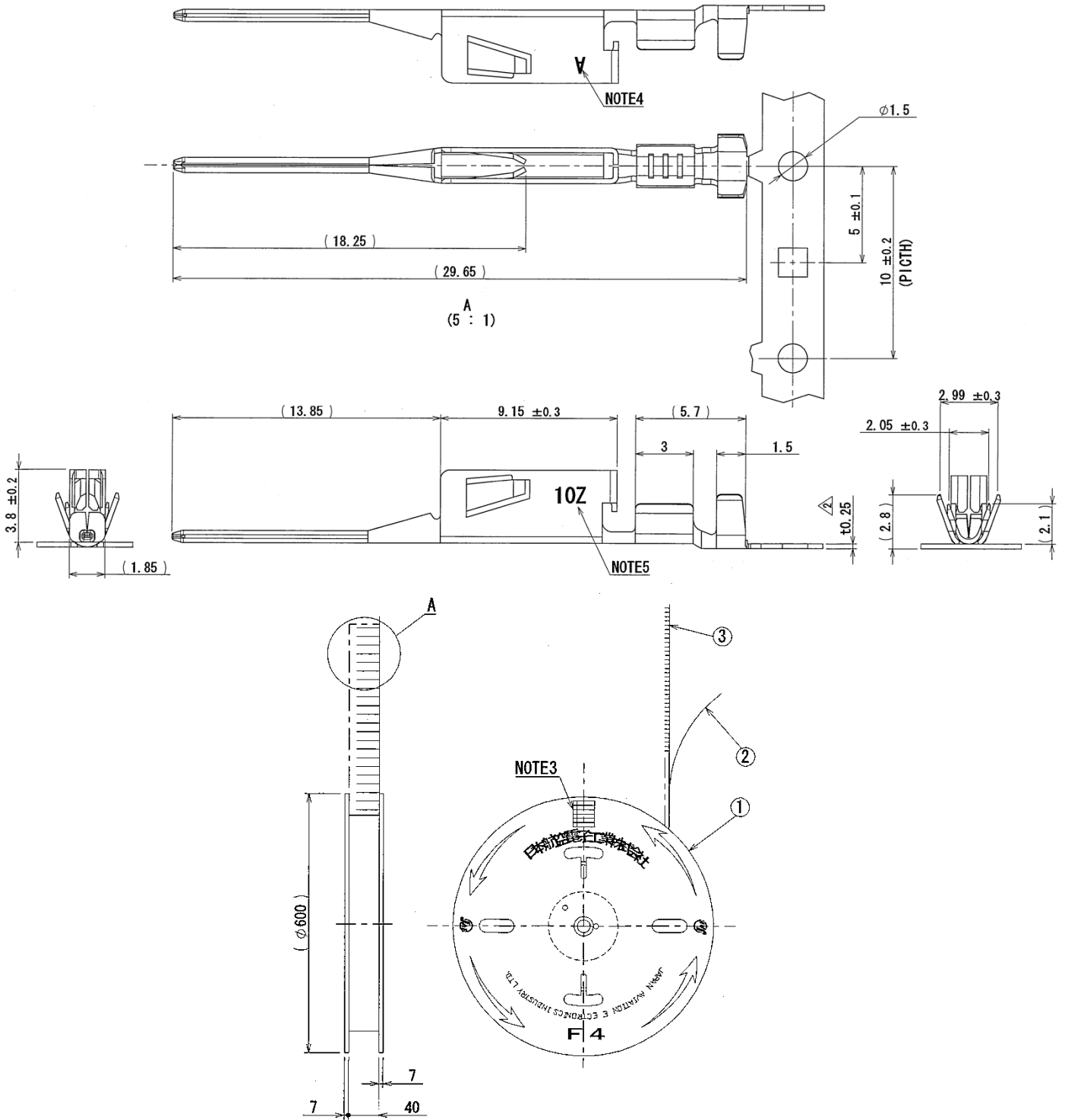

3	PIN CONTACT	4000	COPPER ALLOY	TIN PLATE	—
2	PAPER TAPE	1	PAPER	—	—
1	MAGAZINE	1	PAPER	—	—
符号 NO.	名称 DESCRIPTION	個数 QTY.	材料 MATERIAL	仕上 FINISH	備考 REMARKS

9. Pin Contact for Signal Short (for Receptacle)

Part Number	DW1P04K4F2
SJ Drawing	SJ111312

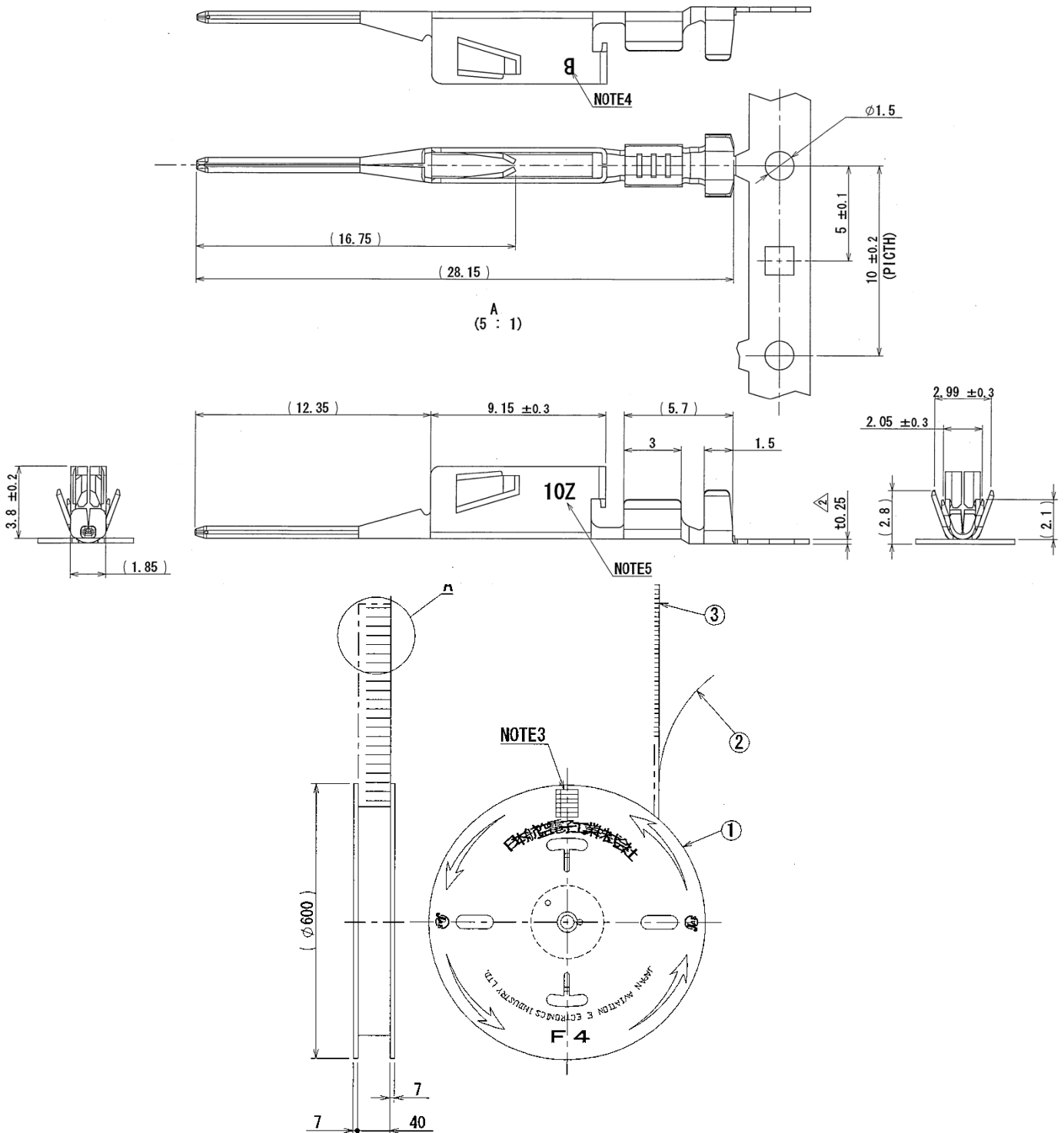

3	PIN CONTACT	4000	COPPER ALLOY	TIN PLATE	—
2	PAPER TAPE	1	PAPER	—	—
1	MAGAZINE	1	PAPER	—	—
符号 NO.	名称 DESCRIPTION	数量 QTY.	材料 MATERIAL	仕上 FINISH	備考 REMARKS

DW2 Series

*Contact is Reel Part Number

Receptacle Side

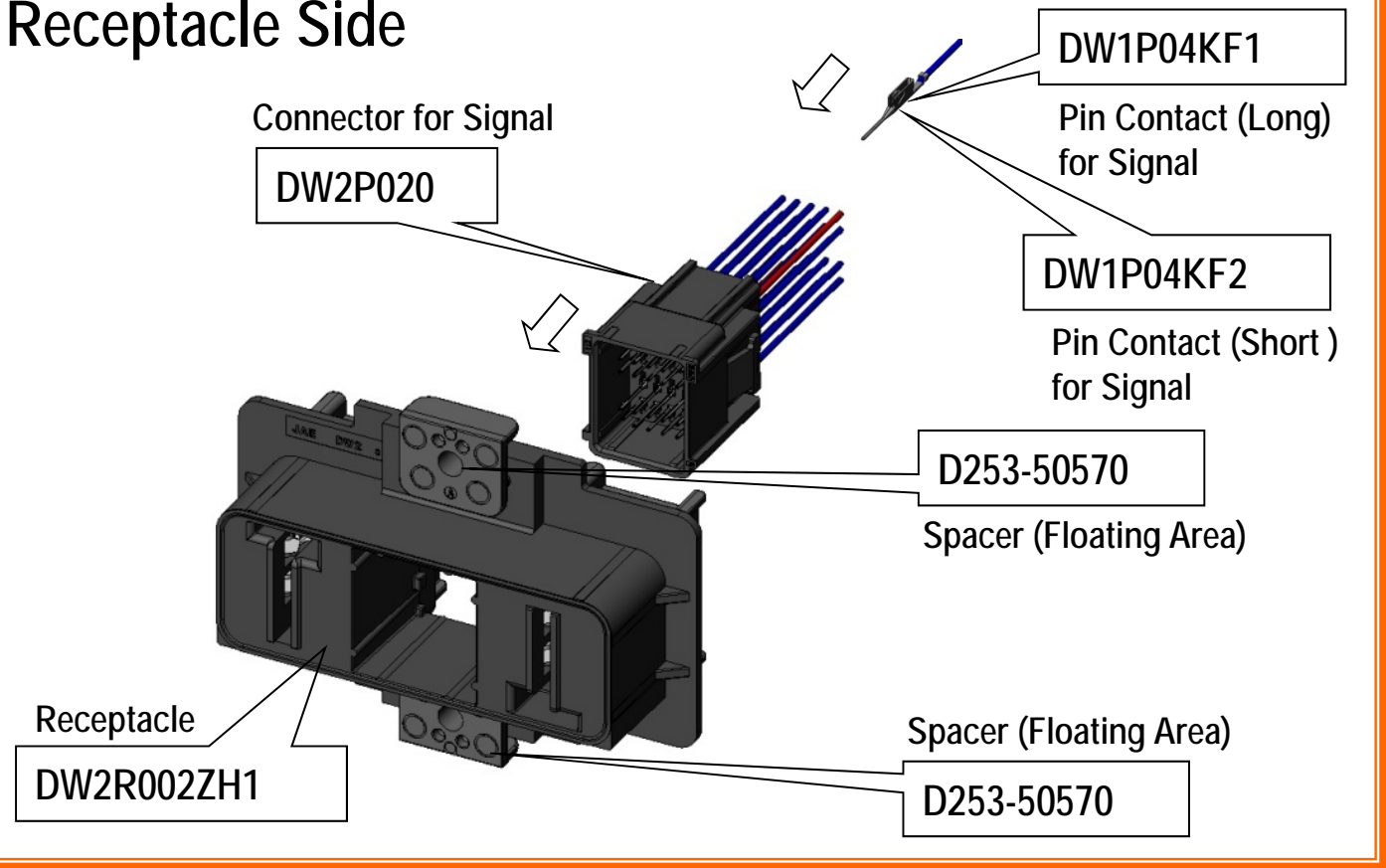

Plug Side

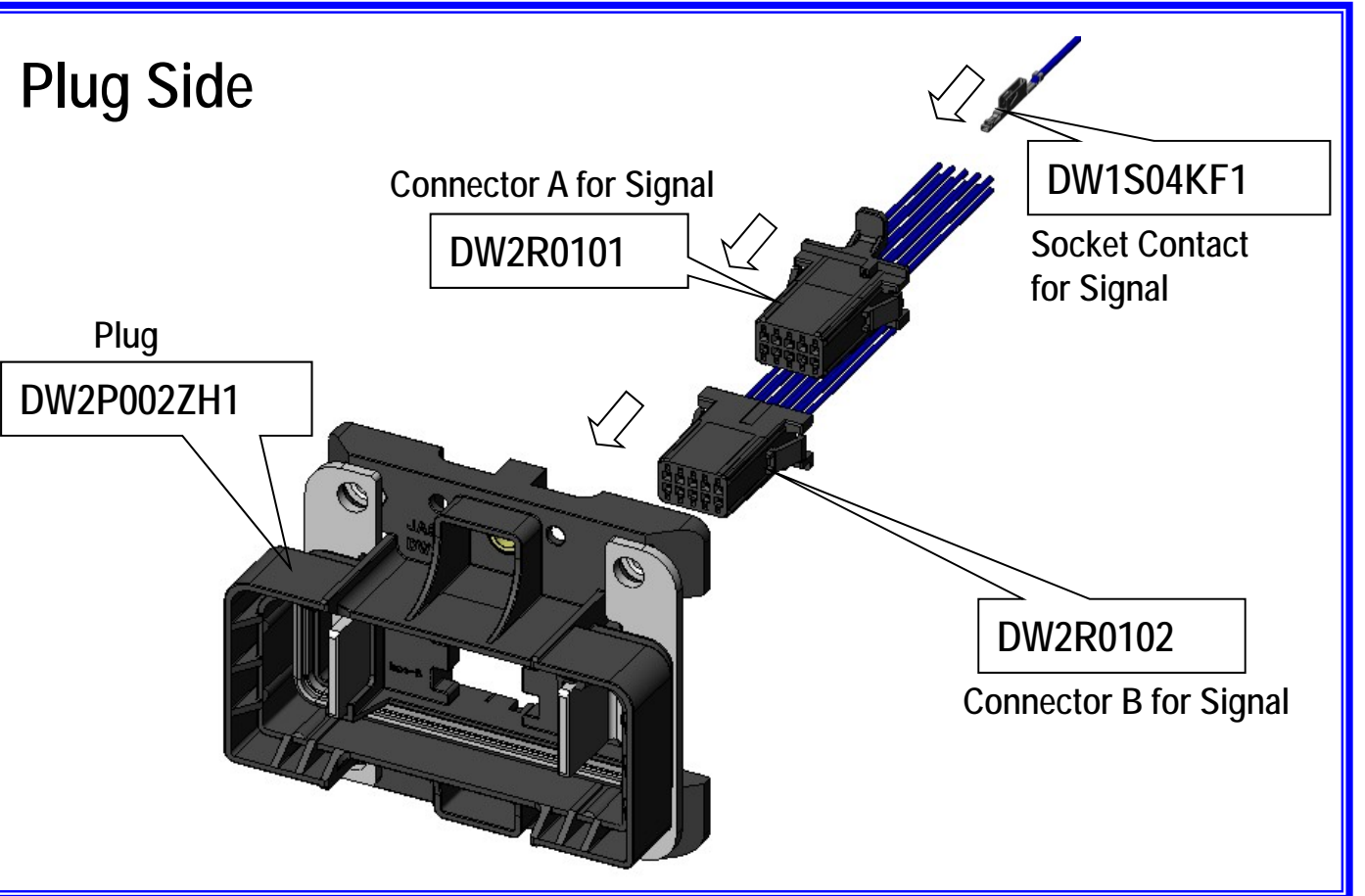

Technical Documents

	Technical Document No. (Document Content)
Product Drawings	SJ112004 (DW2 Receptacle) SJ112005 (DW2 Plug) SJ112006 (DW2 Connector for Signal Receptacle Side) SJ112007 (DW2 Connector A for Signal Plug Side) SJ112008 (DW2 Connector B for Signal Plug Side) SJ112009 (Spacer) SJ111310 (DW1 Socket Contact for Signal) SJ111311 (DW1 Pin Contact Long for Signal) SJ111312 (DW1 Pin Contact Short for Signal)
Specifications	JACS-30188
Handling Instructions	JAHL-30188
Crimp Applicator Handling Instructions	T703488 (f or semi-automatic crimping machine) *Please contact us regarding automatic crimp tool.
Hand Crimp Tool Handling Instructions	T700315

Notice:

1. The values specified in this brochure are only for reference. The products and their specifications are subject to change without notice. Contact our sales staff for further information before considering or ordering any of our products.
For purchase, a product specification must be agreed upon.

2. Users are requested to provide protection circuits and redundancy circuits to ensure safety of the equipment, and sufficiently review the suitability of JAE's products to the equipment.

3. The products presented in this brochure are designed for the uses recommended below.
We strongly suggest you contact our sales staff when considering use of any of the products in any other way than the recommended applications or for a specific use that requires an extremely high reliability.

(1) Applications that require consultation:

(i) Please contact us if you are considering use involving a quality assurance program that you specify or that is peculiar to the industry, such as:

Automotive electrical components, train control, telecommunications devices (mainline), traffic light control, electric power, combustion control, fire prevention or security systems, disaster prevention equipment, etc.

(ii) We may separately give you our support with a quality assurance program that you specify, when you think of a use such as :

Aviation or space equipment, submarine repeaters, nuclear power control systems, medical equipment for life support, etc.

(2) Recommended applications include:

Computers, office appliances, telecommunications devices (terminals, mobile units), measuring equipment, audiovisual equipment, home electric appliances, factory automation equipment, etc

Japan Aviation Electronics Industry, Limited

Product Marketing Division

Aobadai Building, 3-1-19, Aobadai, Meguro-ku, Tokyo 153-8539

Phone: +81-3-3780-2882 FAX: +81-3-3780-2946

* The specifications in this brochure are subject to change without notice. Please contact JAE for information.