

SJ119852
(ON DRAWING) (台異図)

版数 VER.	年月日 DATE	CN NO.	変更内容 DESCRIPTION	製図 DR.	担当 CHK.	査閲 APPD.	承認 APPD.
------------	-------------	--------	---------------------	-----------	------------	-------------	-------------

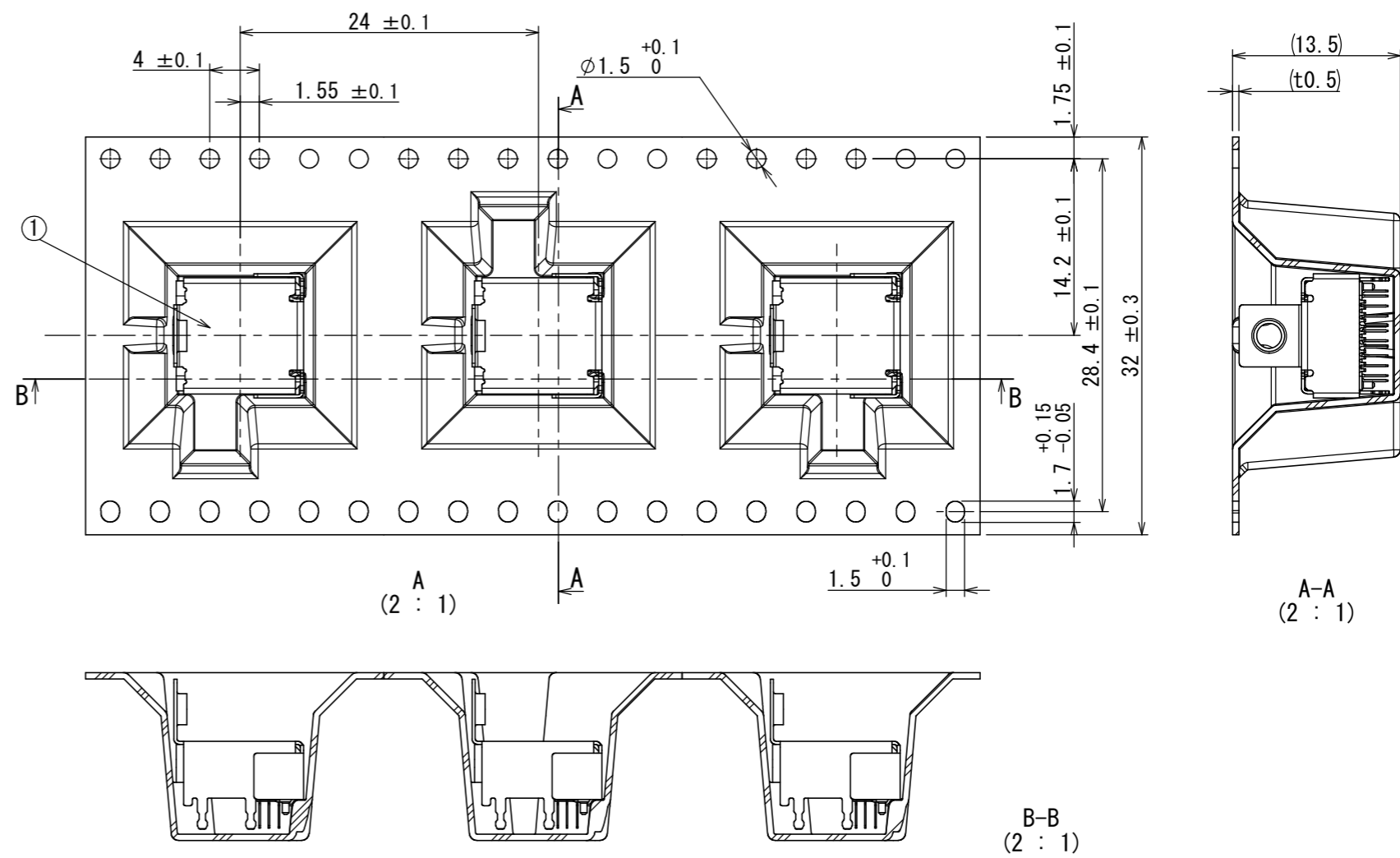
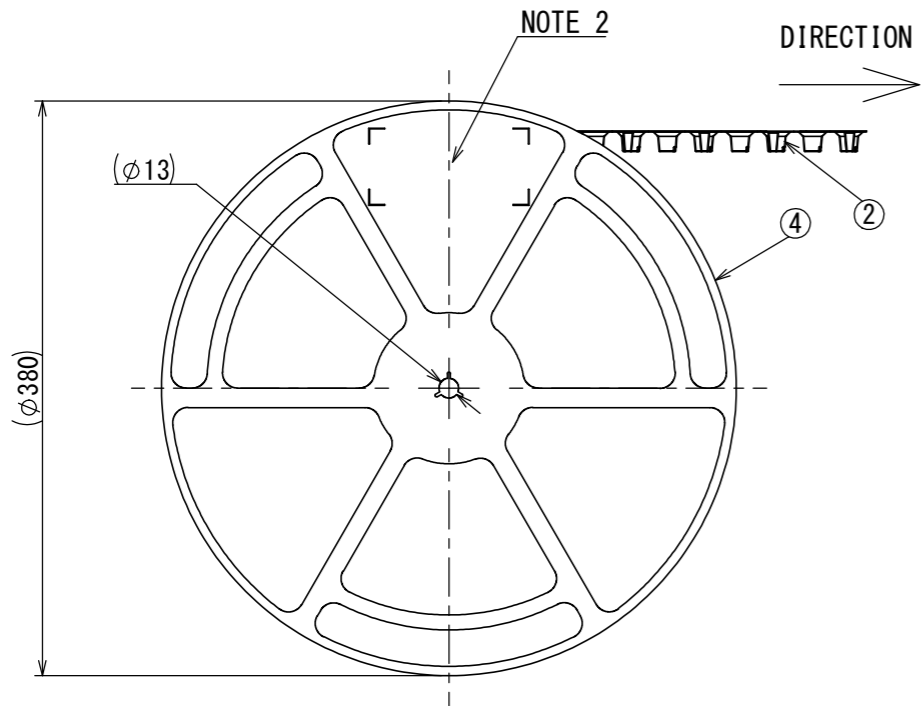

NOTE 1. SUFFIX "R250" OF PART NUMBER "DX07S024XJ4R250" INDICATES 250PCS IN REEL.
 NOTE 2. THE LABEL IN WHICH DESCRIPTION, QTY, LOT NO, EMBOSS CODE AS INDICATED.
 NOTE 3. REFER TO THE DRAWING "SJ119851 (DX07S024XJ4" FOR THE CONNECTOR DIMENSIONS.
 NOTE 4. REEL FORM MAY DIFFER FROM THE DRAWING.

R-Pb (Pb-Free)		COUNTRY OF MANUFACTURE	
台灣航空電子股份有限公司		MADE IN *****	
品名	DX07S024XJ4R250		
収納数	250	個入	製造年月日
備考	TB3224		

32: TAPE WIDTH 24: FEED PITCH NUMBER OF CONNTECTOR

符号 NO.	名称 DESCRIPTION	個数 QTY.	材料 MATERIAL	仕上 FINISH	備考 REMARKS
4	REEL	1	PS	-	-
3	COVER TAPE	1	PET	-	-
2	CARRIER TAPE	1	PS	-	-
1	DX07S024XJ4	250	-	-	SJ119851

仕様書 (SPECIFICATION) JACS-30361	第1版 (ORIGINAL DATE) 16/APR/2018	尺度 (SCALE) 1:5	シリーズ (SERIES) DX07	名称 (TITLE) DX07S024XJ4R250	製造 DR. -	担当 CHK. J. OOSAKA	査閲 APPD. -	承認 APPD. Y. SAITOU	質量 (MASS)	日本航空電子工業株式会社 JAE JAPAN AVIATION ELECTRONICS INDUSTRY, LTD.	図面番号 (DRAWING NO.) SJ119852	版数 (VER.) 1
-----------------------------------	------------------------------------	-------------------	-----------------------	-------------------------------	-------------	----------------------	---------------	-----------------------	-----------	--	--------------------------------	----------------

S/W

WISDOM承認 2018/04/20

DCF-C-212H(12.08)

