

版数 VER.	年月日 DATE	図 NO.	変更内容 DESCRIPTION	製 DR.	担 CHK.	査 APPD.	承認 APPD.
2	19/AUG/2013	007107	Correction of errors.		S. YAMAGUCHI	R. KATOU	T. SHINDOU
3	26/JUN/2014	008839	Specification is changed.		S. YAMAGUCHI	M. SASAKI	T. SHINDOU
4	26/AUG/2014	010618	Correction of errors.		S. YAMAGUCHI	M. SASAKI	T. SHINDOU
5	29/JAN/2015	012209	Added dimension etc.		S. YAMAGUCHI	M. SASAKI	T. SHINDOU

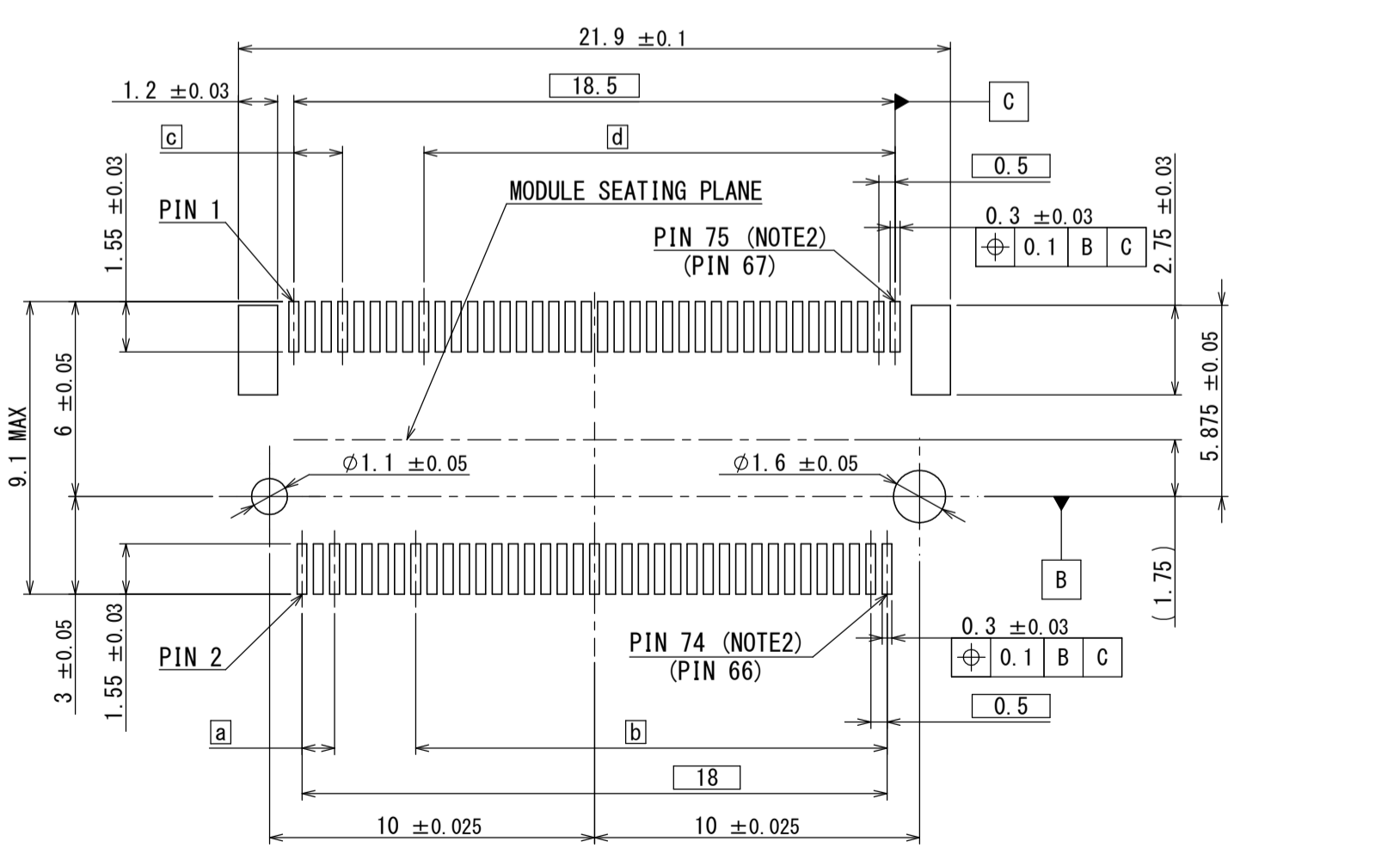

APPLICABLE P.C.B. DIMENSION (REF.)
SCALE (5:1)

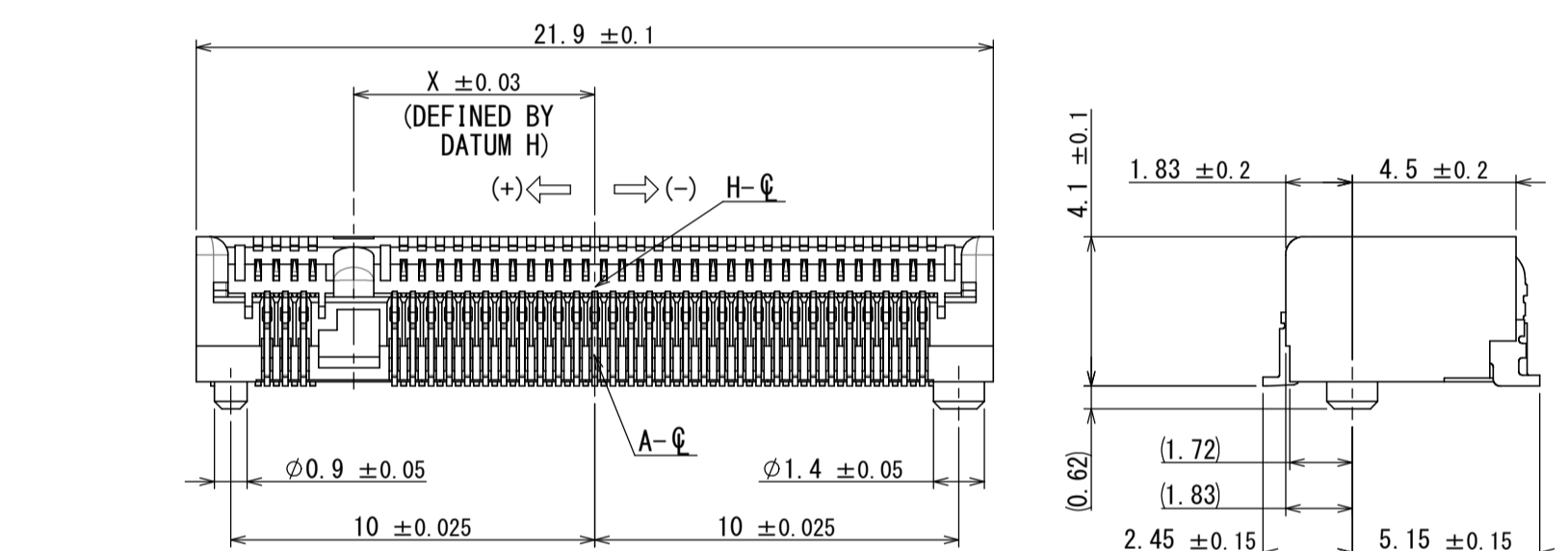
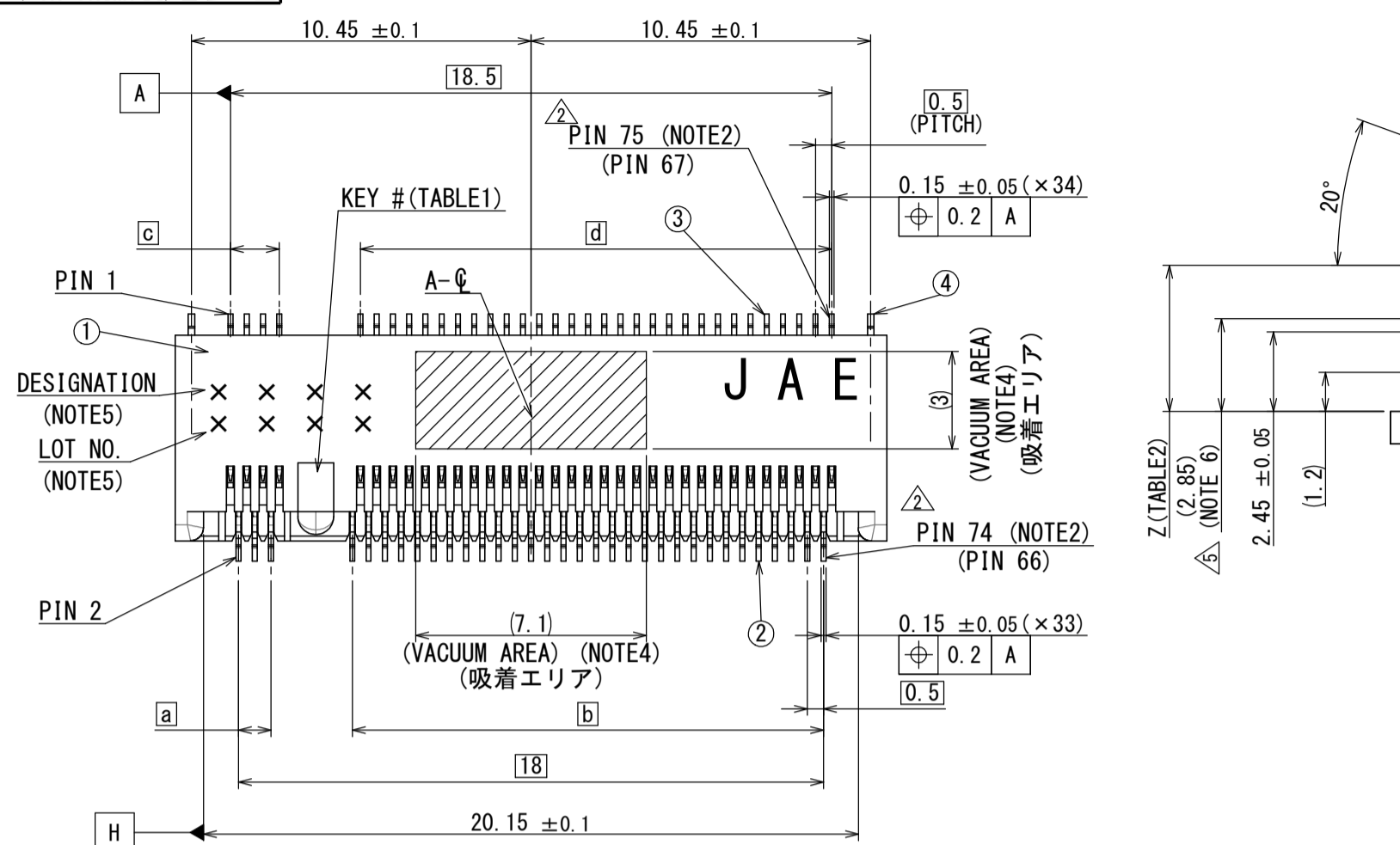
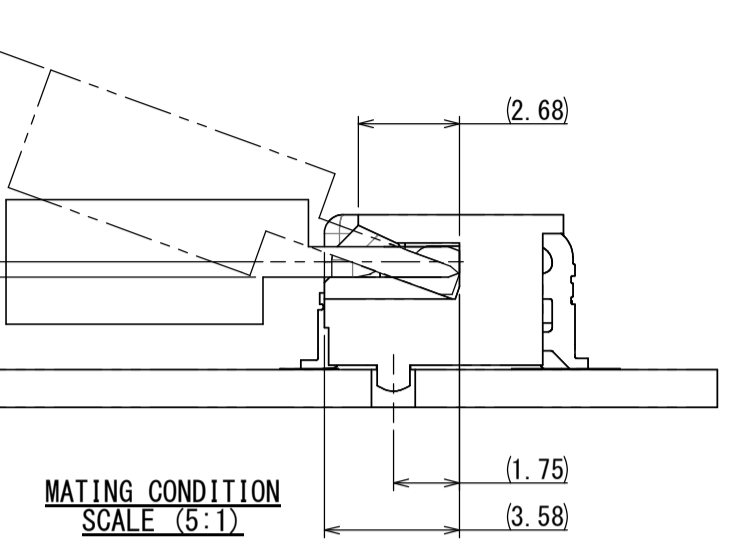

MATING CONDITION
SCALE (5:1)

NOTE5. PRODUCTION LOT No. & MODIFY CODE AS INDICATED.
(Ex. LOT NO.) T 5 Y B

LOT NUMBER OF CURRENT DAY
(SEE TABLE 4)
MONTH (1 TO 9 FOR JAN. TO SEPT.
RESPECTIVELY,
OCT.:0, NOV.:X, DEC.:Y)
YEAR (LAST DIGIT ONLY)
MANUFACTURE CODE

(DESIGNATION) S M 3 A
KEY POSITION
TYPE: A, B, E, M
SERIES PREFIX

DESIGNATION

SM3ZS067U410**
SERIES シリーズ
Z: LIF TYPE
Z: 低挿入タイプ
S: STANDARD
NO. OF CONTACTS 芯数
MOUNTING TYPE 実装タイプ
U: ON BOARD TYPE
KEY POSITION TYPE: A, B, E, M
CONTACT FINISH 接点仕上げ
T: Au (0.025 μm MIN)
A: Au (0.13 μm MIN)
B: Au (0.25 μm MIN)
PRODUCT HEIGHT 製品高さ
215: 2.15mm
310: 3.10mm
410: 4.10mm

TABLE 1

KEY#	X	a	b	c	d
A	+6.625	1	14.5	1.5	14.5
B	+5.625	2	13.5	2.5	13.5
E	+2.625	5	10.5	5.5	10.5
M	-6.125	14	1.5	14	2

TABLE 2

COMPONENT HEIGHTS FOR MODULES	Z
1.2 MAX	4.55 MAX RSS
1.35 MAX	4.70 MAX RSS
1.5 MAX	4.85 MAX RSS

NOTE1. THE COPLANARITY OF CONTACT AND HOLD DOWN SHALL BE 0.1 MAXIMUM ON THE SURFACE TABLE.
NOTE2. THIS NUMBER IS PIN-OUT NUMBER DEFINED BY NGFF SPECIFICATION.
NOTE3. THIS CONNECTOR IS HALOGEN FREE CORRESPONDENCE PRODUCT.
NOTE4. THIS AREA SHALL NOT SHOW ANY BURRS AND UNEVEN SURFACE BY EJECTOR PIN MARK, TOOL PARTING LINE, AND ANY OTHER FACTORS.
NOTE6. THE HEIGHT TO THE MODULE CARD CENTER FROM P.C.B. SURFACE.

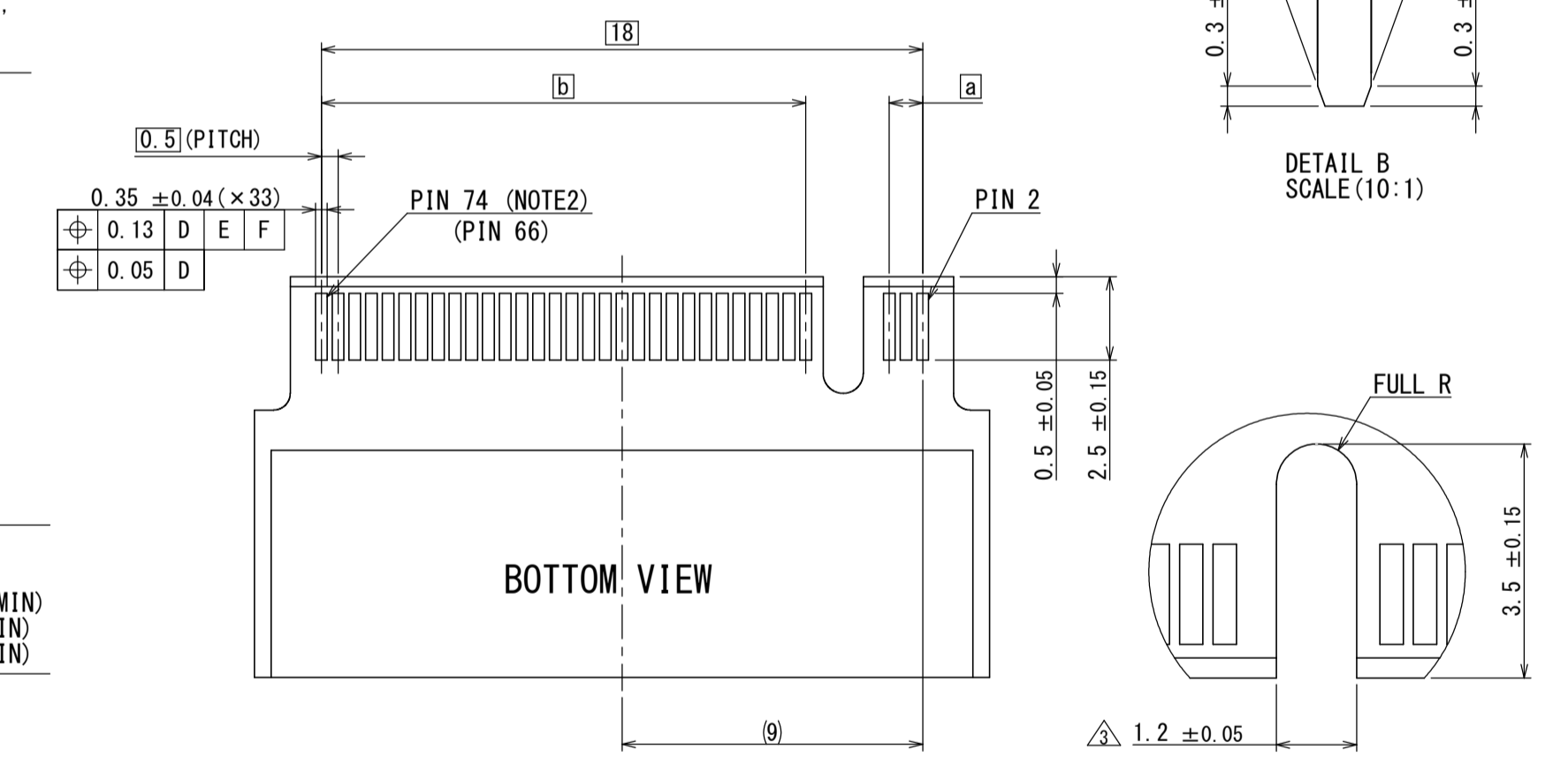
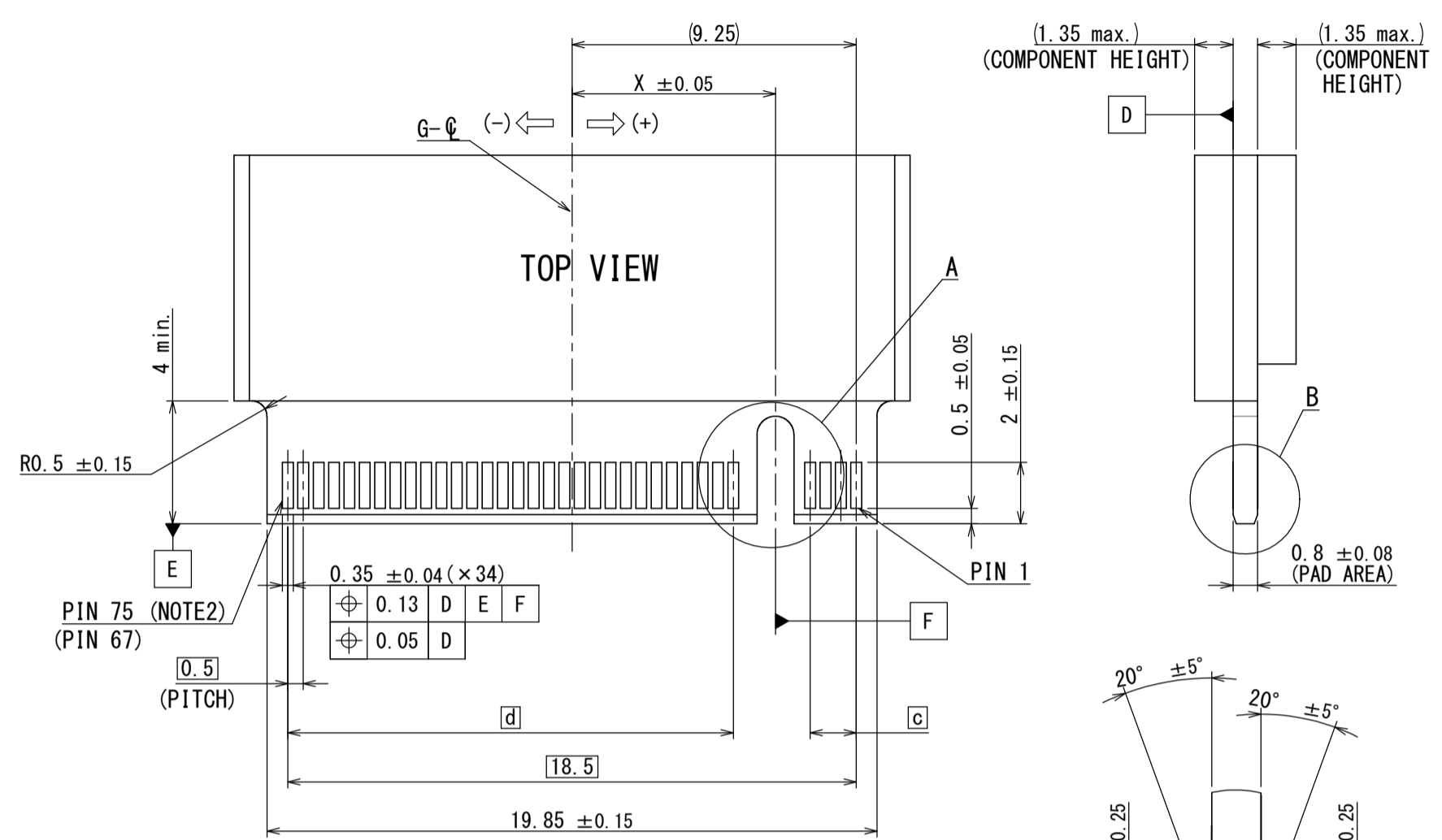

APPLICABLE MODULE DIMENSION (REF.)
SCALE (5:1)

号 NO.	名 DESCRIPTION	個 QTY.	材 MATERIAL	仕 FINISH	備 REMARKS
4	HOLD DOWN	2	COPPER ALLOY	TIN PLATING OVER NI	—
3	TOP SIDE CONTACT	34	COPPER ALLOY	CONTACT AREA: REFER TO DESIGNATION SOLDERING AREA: Au FLASH OVER Ni	—
2	BOTTOM SIDE CONTACT	33	COPPER ALLOY	CONTACT AREA: REFER TO DESIGNATION SOLDERING AREA: Au FLASH OVER Ni	—
1	INSULATOR	1	THERMO PLASTIC	—	—

仕様書 (SPECIFICATION)		第1版 (ORIGINAL DATE) 08/JAN/2013		尺度 (SCALE) 5:1		シリーズ (SERIES) SM3	
製 DR.		S. YAMAGUCHI		名 TITILE		SM3ZS067U410** (NGFF Double-Sided modules)	
担 CHK.		R. KATOU		製 DR.		S. YAMAGUCHI	
査 APPD.		T. SHINDOU		名 TITILE		SM3ZS067U410** (NGFF Double-Sided modules)	
承 APPD.				製 DR.		S. YAMAGUCHI	
承認 APPD.				名 TITILE		SM3ZS067U410** (NGFF Double-Sided modules)	
単位 (UNIT): mm				製 DR.		S. YAMAGUCHI	
				名 TITILE		SM3ZS067U410** (NGFF Double-Sided modules)	
				製 DR.		S. YAMAGUCHI	
				名 TITILE		SM3ZS067U410** (NGFF Double-Sided modules)	
				製 DR.		S. YAMAGUCHI	
				名 TITILE		SM3ZS067U410** (NGFF Double-Sided modules)	
				製 DR.		S. YAMAGUCHI	
				名 TITILE		SM3ZS067U410** (NGFF Double-Sided modules)	
				製 DR.		S. YAMAGUCHI	
				名 TITILE		SM3ZS067U410** (NGFF Double-Sided modules)	
				製 DR.		S. YAMAGUCHI	
				名 TITILE		SM3ZS067U410** (NGFF Double-Sided modules)	
				製 DR.		S. YAMAGUCHI	
				名 TITILE		SM3ZS067U410** (NGFF Double-Sided modules)	
				製 DR.		S. YAMAGUCHI	
				名 TITILE		SM3ZS067U410** (NGFF Double-Sided modules)	
				製 DR.		S. YAMAGUCHI	
				名 TITILE		SM3ZS067U410** (NGFF Double-Sided modules)	
				製 DR.		S. YAMAGUCHI	
				名 TITILE		SM3ZS067U410** (NGFF Double-Sided modules)	
				製 DR.		S. YAMAGUCHI	
				名 TITILE		SM3ZS067U410** (NGFF Double-Sided modules)	
				製 DR.		S. YAMAGUCHI	
				名 TITILE		SM3ZS067U410** (NGFF Double-Sided modules)	
				製 DR.		S. YAMAGUCHI	
				名 TITILE		SM3ZS067U410** (NGFF Double-Sided modules)	
				製 DR.		S. YAMAGUCHI	
				名 TITILE		SM3ZS067U410** (NGFF Double-Sided modules)	
				製 DR.		S. YAMAGUCHI	
				名 TITILE		SM3ZS067U410** (NGFF Double-Sided modules)	
				製 DR.		S. YAMAGUCHI	
				名 TITILE		SM3ZS067U410** (NGFF Double-Sided modules)	
				製 DR.		S. YAMAGUCHI	
				名 TITILE		SM3ZS067U410** (NGFF Double-Sided modules)	
				製 DR.		S. YAMAGUCHI	
				名 TITILE		SM3ZS067U410** (NGFF Double-Sided modules)	
				製 DR.		S. YAMAGUCHI	
				名 TITILE		SM3ZS067U410** (NGFF Double-Sided modules)	
				製 DR.		S. YAMAGUCHI	
				名 TITILE		SM3ZS067U410** (NGFF Double-Sided modules)	
				製 DR.		S. YAMAGUCHI	
				名 TITILE		SM3ZS067U410** (NGFF Double-Sided modules)	
				製 DR.		S. YAMAGUCHI	
				名 TITILE		SM3ZS067U410** (NGFF Double-Sided modules)	
				製 DR.		S. YAMAGUCHI	
				名 TITILE		SM3ZS067U410** (NGFF Double-Sided modules)	
				製 DR.		S. YAMAGUCHI	
				名 TITILE		SM3ZS067U410** (NGFF Double-Sided modules)	
				製 DR.		S. YAMAGUCHI	
				名 TITILE		SM3ZS067U410** (NGFF Double-Sided modules)	
				製 DR.		S. YAMAGUCHI	
				名 TITILE		SM3ZS067U410** (NGFF Double-Sided modules)	
				製 DR.		S. YAMAGUCHI	
				名 TITILE		SM3ZS067U410** (NGFF Double-Sided modules)	
				製 DR.		S. YAMAGUCHI	
				名 TITILE		SM3ZS067U410** (NGFF Double-Sided modules)	
				製 DR.		S. YAMAGUCHI	
				名 TITILE		SM3ZS067U410** (NGFF Double-Sided modules)	
				製 DR.		S. YAMAGUCHI	
				名 TITILE		SM3ZS067U410** (NGFF Double-Sided modules)	
				製 DR.		S. YAMAGUCHI	
				名 TITILE		SM3ZS067U410** (NGFF Double-Sided modules)	
				製 DR.		S. YAMAGUCHI	
				名 TITILE		SM3ZS067U410** (NGFF Double-Sided modules)	
				製 DR.		S. YAMAGUCHI	
				名 TITILE		SM3ZS067U410** (NGFF Double-Sided modules)	
				製 DR.		S. YAMAGUCHI	
				名 TITILE		SM3ZS067U410** (NGFF Double-Sided modules)	
				製 DR.		S. YAMAGUCHI	
				名 TITILE		SM3ZS067U410** (NGFF Double-Sided modules)	
				製 DR.		S. YAMAGUCHI	
				名 TITILE		SM3ZS067U410** (NGFF Double-Sided modules)	
				製 DR.		S. YAMAGUCHI	
				名 TITILE		SM3ZS067U410** (NGFF Double-Sided modules)	
				製 DR.		S. YAMAGUCHI	
				名 TITILE		SM3ZS067U410** (NGFF Double-Sided modules)	
				製 DR.		S. YAMAGUCHI	
				名 TITILE		SM3ZS067U410** (NGFF Double-Sided modules)	
				製 DR.		S. YAMAGUCHI	
				名 TITILE		SM3ZS067U410** (NGFF Double-Sided modules)	
				製 DR.		S. YAMAGUCHI	
				名 TITILE		SM3ZS067U410** (NGFF Double-Sided modules)	
				製 DR.		S. YAMAGUCHI	
				名 TITILE		SM3ZS067U410** (NGFF Double-Sided modules)	
				製 DR.		S. YAMAGUCHI	
				名 TITILE		SM3ZS067U410** (NGFF Double-Sided modules)	
				製 DR.		S. YAMAGUCHI	
				名 TITILE		SM3ZS067U410** (NGFF Double-Sided modules)	
				製 DR.		S. YAMAGUCHI	
				名 TITILE		SM3ZS067U410** (NGFF Double-Sided modules)	
				製 DR.		S. YAMAGUCHI	
				名 TITILE		SM3ZS067U410** (NGFF Double-Sided modules)	
				製 DR.		S. YAMAGUCHI	
				名 TITILE		SM3ZS067U410** (NGFF Double-Sided modules)	
				製 DR.		S. YAMAGUCHI	
				名 TITILE		SM3ZS067U410** (NGFF Double-Sided modules)	
				製 DR.		S. YAMAGUCHI	
				名 TITILE		SM3ZS067U410** (NGFF Double-Sided modules)	
				製 DR.		S. YAMAGUCHI	
				名 TITILE		SM3ZS067U410** (NGFF Double-Sided modules)	
				製 DR.		S. YAMAGUCHI	
				名 TITILE		SM3ZS067U410** (NGFF Double-Sided modules)	
				製 DR.		S. YAMAGUCHI	
				名 TITILE		SM3ZS067U410** (NGFF Double-Sided modules)	
				製 DR.		S. YAMAGUCHI	
				名 TITILE		SM3ZS067U410** (NGFF Double-Sided modules)	
				製 DR.		S. YAMAGUCHI	
				名 TITILE		SM3ZS067U410** (NGFF Double-Sided modules)	
				製 DR.		S. YAMAGUCHI	
				名 TITILE		SM3ZS067U410** (NGFF Double-Sided modules)	
				製 DR.		S. YAMAGUCHI	
				名 TITILE		SM3ZS067U410** (NGFF Double-Sided modules)	
				製 DR.		S. YAMAGUCHI	
				名 TITILE		SM3ZS067U410** (NGFF Double-Sided modules)	
				製 DR.		S. YAMAGUCHI	
				名 TITILE		SM3ZS067U410** (NGFF Double-Sided modules)	
				製 DR.		S. YAMAGUCHI	
				名 TITILE		SM3ZS067U410** (NGFF Double-Sided modules)	
				製 DR.		S. YAMAGUCHI	
				名 TITILE		SM3ZS067U410** (NGFF Double-Sided modules)	
				製 DR.		S. YAMAGUCHI	
				名 TITILE		SM3ZS067U410** (NGFF Double-Sided modules)	
				製 DR.		S. YAMAGUCHI	
				名 TITILE		SM3ZS067U410** (NGFF Double-Sided modules)	
				製 DR.		S. YAMAGUCHI	
				名 TITILE		SM3ZS067U410** (NGFF Double-Sided modules)	
				製 DR.		S. YAMAGUCHI	
				名 TITILE		SM3ZS067U410** (NGFF Double-Sided modules)	
				製 DR.		S. YAMAGUCHI	
				名 TITILE		SM3ZS067U410** (NGFF Double-Sided modules)	
				製 DR.		S. YAMAGUCHI	
				名 TITILE		SM3ZS067U410** (NGFF Double-Sided modules)	
				製 DR.		S. YAMAGUCHI	
				名 TITILE		SM3ZS067U410** (NGFF Double-Sided modules)	
				製 DR.		S. YAMAGUCHI	
				名 TITILE		SM3ZS067U410** (NGFF Double-Sided modules)	
				製 DR.		S. YAMAGUCHI	
				名 TITILE		SM3ZS067U410** (NGFF Double-Sided modules)	
				製 DR.		S. YAMAGUCHI	
				名 TITILE		SM3ZS067U410** (NGFF Double-Sided modules)	
				製 DR.		S. YAMAGUCHI	
				名 TITILE		SM3ZS067U410** (NGFF Double-Sided modules)	
				製 DR.		S. YAMAGUCHI	
				名 TITILE		SM3ZS067U410** (NGFF Double-Sided modules)	
				製 DR.		S. YAMAGUCHI	
				名 TITILE		SM3ZS067U410** (NGFF Double-Sided modules)	
				製 DR.		S.	