

THIS DOCUMENT IS THE PROPERTY OF KEYSTONE ELECTRONICS CORP. AND SHALL NOT BE REPRODUCED, DISTRIBUTED OR USED AS A BASIS FOR MANUFACTURE WITHOUT PRIOR WRITTEN PERMISSION FROM KEYSTONE ELECTRONICS CORP.

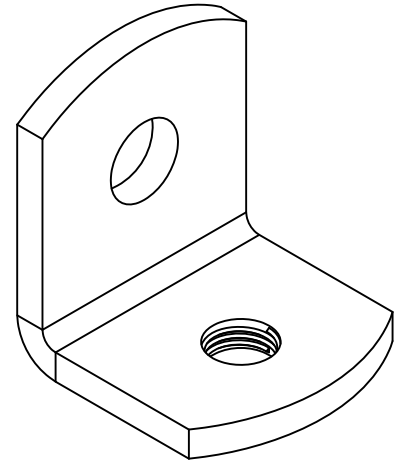

$\pm .005$  [ $\pm 0.15$ ]  
 $.165$  [4.19] DIA. HOLE

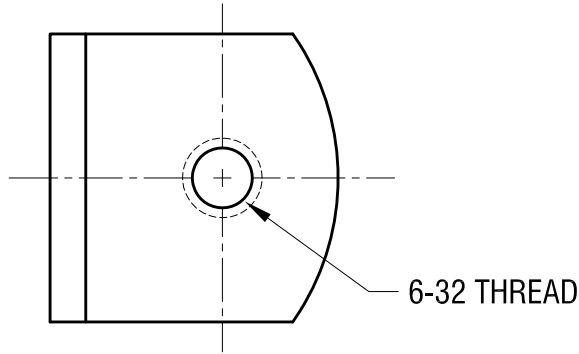
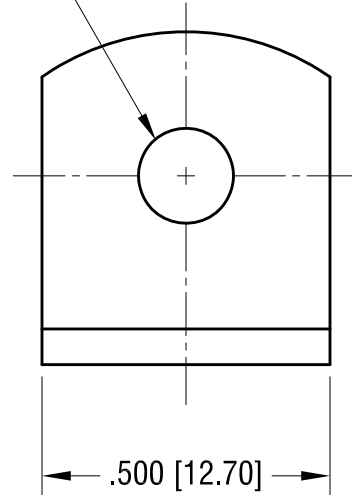
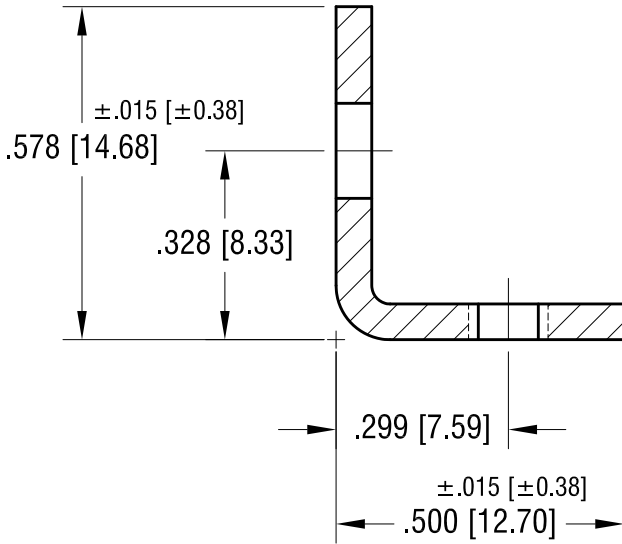

**KEYSTONE ELECTRONICS CORP.**

www.keyelco.com • ASTORIA, N.Y. 11105-2017 • Tel (718) 956-8900

PART NAME		THREADED MOUNTING BRACKET	
MATERIAL		.062 [1.57] TH'K STEEL	
FINISH	DRN BY	BOONE	DATE
MATTE TIN PLATE	APP'D	LN	2.26.82
TOLERANCES	INCH	[MM]	SCALE
DECIMAL	$\pm .010$	[ $\pm 0.25$ ]	3X
ANGULAR	$\pm 1^\circ$		
UNLESS OTHERWISE SPECIFIED		CODE	DWG NO.
		C	617

9.19.09	CHANGE PER ECN 09-136	C
11.12.97	CHANGE PER ECR 97-060	B
4.20.93	REVISED	A
DATE	DESCRIPTION	REV.