

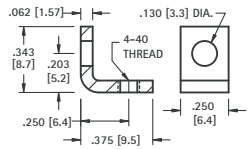

THREADED MOUNTING BRACKETS

THREADED MOUNTING BRACKETS

4-40 THREAD

CAT. NO. 612 **MATERIAL:**
.062 (1.57) Steel, Zinc Plate

4-40 THREAD

CAT. NO. 621 **MATERIAL:**
.062 (1.57) Steel, Zinc Plate

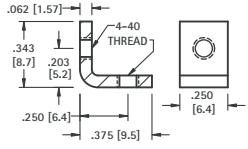
4-40 THREAD

CAT. NO. 616 **MATERIAL:**
.047 (1.19) Brass, Tin Plate

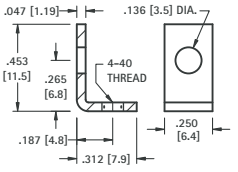
6-32 THREAD

CAT. NO. 634 **MATERIAL:**
.032 (.81) Brass, Nickel Plate

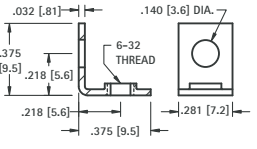
6-32 THREAD

CAT. NO. 614 **MATERIAL:**
.032 (.81) Brass, Tin Plate

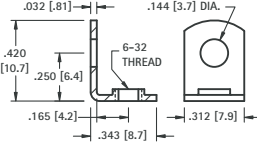
6-32 THREAD

CAT. NO. 632 **MATERIAL:**
.032 (.81) Brass, Tin Plate

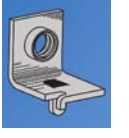
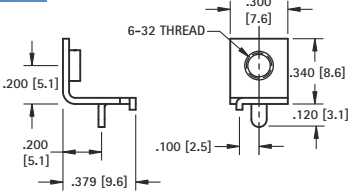
6-32 THREAD

CAT. NO. 4334 **MATERIAL:**
.062 (1.57) Steel, Nickel Plate

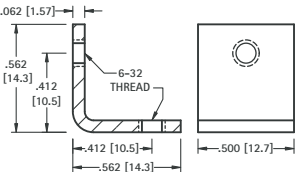
6-32 THREAD

CAT. NO. 708 **MATERIAL:**
.062 (1.57) Steel, Nickel Plate

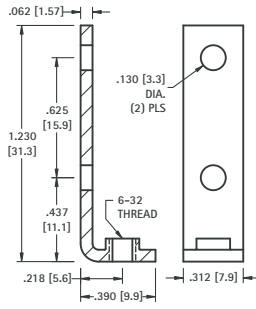
6-32 THREAD

CAT. NO. 617 **MATERIAL:**
.062 (1.57) Steel, Tin Plate

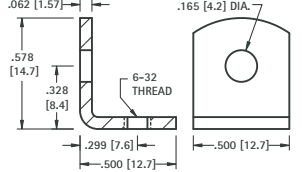
6-32 OR 8-32 THREAD

CAT. NO.	THREAD
4332	6-32
4333	8-32

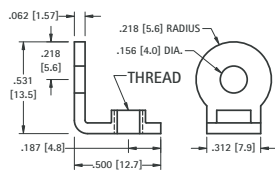
MATERIAL:
.062 (1.57) Brass, Nickel Plate

8-32 THREAD

CAT. NO. 611 **MATERIAL:**
.037 (.94) Brass, Tin Plate

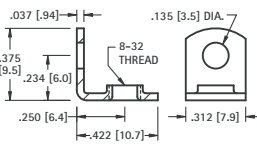
8-32 THREAD

CAT. NO. 631 **MATERIAL:**
.037 (.94) Steel, Tin Plate

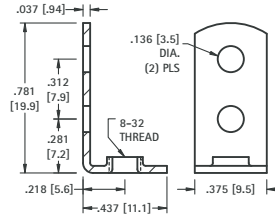



SNAP-IN THREADED PC MOUNT BRACKETS

- Snaps in for wave soldering • Reduces assembly time • Easily mount into predrilled or punched holes • Stable no rock design

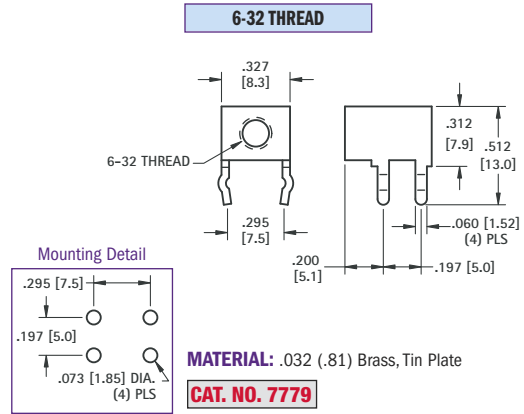
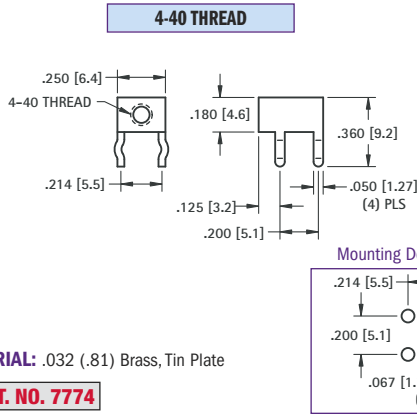
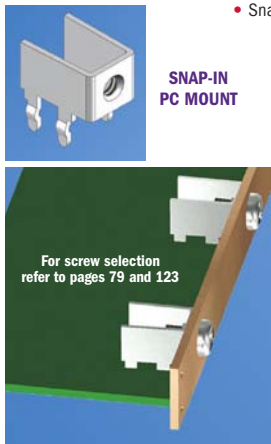

UNIVERSAL CLEAR HOLE BRACKETS

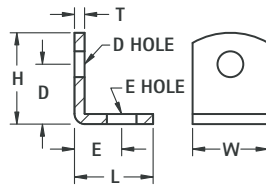

CAT. NO.	H	L	W	D	D HOLE DIAMETER	E	E HOLE DIAMETER	T	MATERIAL	FINISH
633	.375 (9.5)	.375 (9.5)	.281 (7.1)	.218 (5.5)	.140 (3.6)	.218 (5.5)	.140 (3.6)	.032 (.81)	Brass	Nickel
613	.390 (9.9)	.453 (11.5)	.375 (9.5)	.234 (5.9)	.147 (3.7)	.299 (7.6)	.128 (3.3)	.032 (.81)	Brass	Nickel
615	.420 (10.7)	.343 (8.7)	.281 (7.1)	.281 (7.1)	.144 (3.7)	.203 (5.2)	.128 (3.3)	.032 (.81)	Brass	Tin
4335	.562 (14.3)	.562 (14.3)	.500 (12.7)	.412 (10.5)	.120 (3.0)	.411 (10.4)	.120 (3.0)	.062 (1.57)	Steel	Nickel
4336	.562 (14.3)	.562 (14.3)	.500 (12.7)	.412 (10.5)	.144 (3.7)	.412 (10.5)	.144 (3.7)	.062 (1.57)	Steel	Nickel
618	.628 (16.0)	.628 (16.0)	.375 (9.5)	.378 (9.6)	.169 (4.3)	.378 (9.6)	.169 (4.3)	.050 (1.27)	Brass	Tin
619	.687 (17.4)	.687 (17.4)	.375 (9.5)	.500 (12.7)	.144 (3.7)	.500 (12.7)	.144 (3.7)	.032 (.81)	Steel	Tin
4326	1.013 (25.7)	.487 (12.4)	.312 (7.9)	.816 (20.7)	.140 (3.6)	.332 (8.4)	.140 (3.6)	.050 (1.27)	Steel	Nickel
620	1.156 (29.4)	.656 (16.7)	.375 (9.5)	.906 (23.0)	.169 (4.3)	.420 (10.7)	.169 (4.3)	.032 (.81)	Steel	Tin

BOARD BRACKETS



Originally designed for our line of standardized terminal boards; these brackets can also be used in other applications. See pages 148-149 for Turret Terminal Boards.

MATERIALS: .062 (1.57) Steel, Nickel Plate

CAT. NO.	W	L	S
1570	.281 (7.1)	1.187 (30.1)	.750 (19.1)
1556	.375 (9.5)	1.625 (41.3)	1.000 (25.4)
1571	.281 (7.1)	1.625 (41.3)	1.187 (30.1)
1567	.375 (9.5)	2.125 (54.0)	1.500 (38.1)
1568	.375 (9.5)	2.625 (66.7)	2.000 (50.8)
1569	.375 (9.5)	3.125 (79.4)	2.500 (63.5)

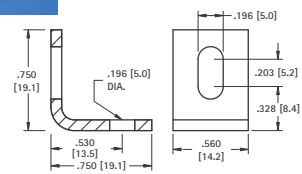
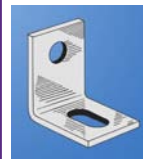
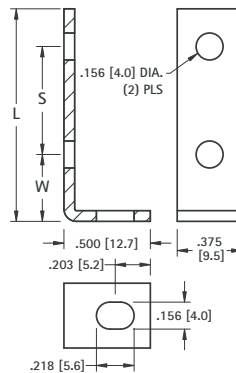

CAT. NO. 4337 **MATERIAL:** .080 (2.03) Aluminum

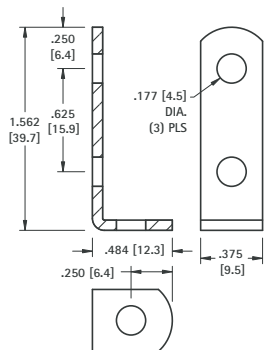

CAT. NO. 1564 **MATERIAL:** .062 (1.57) Steel, Nickel Plate

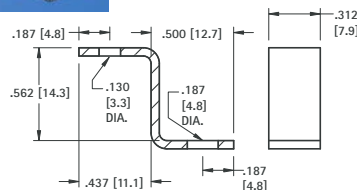

CAT. NO. 4325 **MATERIAL:** .050 (1.27) Steel, Nickel Plate

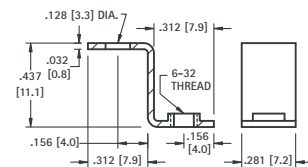

CAT. NO. 630 **MATERIAL:** .032 (.81) Brass, Tin Plate



X-ON Electronics

Authorized Distributor

Click to view similar products for [Mounting Hardware](#) category:

[895-39228](#) [1201280](#) [1201358](#) [R501-000-021](#) [1277](#) [155-012](#) [15504](#) [1597Y](#) [2701761](#) [301-9004-01](#)