

THIS DOCUMENT IS THE PROPERTY OF KEYSTONE ELECTRONICS CORP. AND SHALL NOT BE REPRODUCED, DISTRIBUTED OR USED AS A BASIS FOR MANUFACTURE WITHOUT PRIOR WRITTEN PERMISSION FROM KEYSTONE ELECTRONICS CORP.

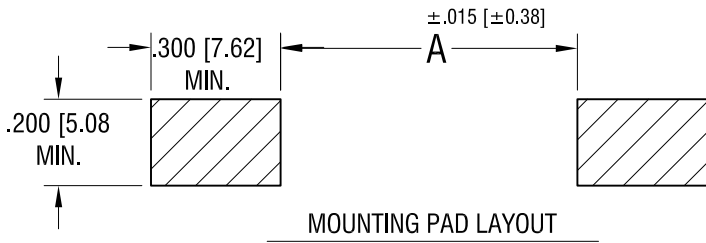

FOR BATTERY SIZE:	'A' DIM.
2/3A	1.71 [43.4]
AA	2.380 [60.45]

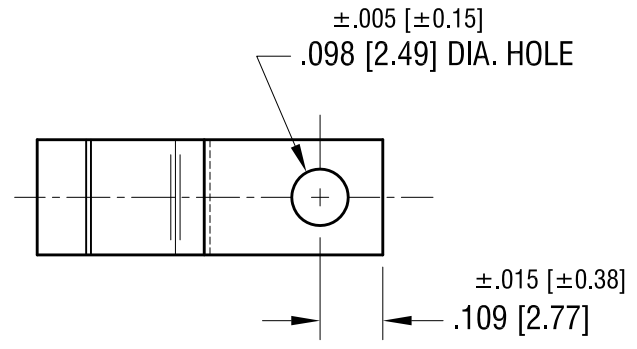
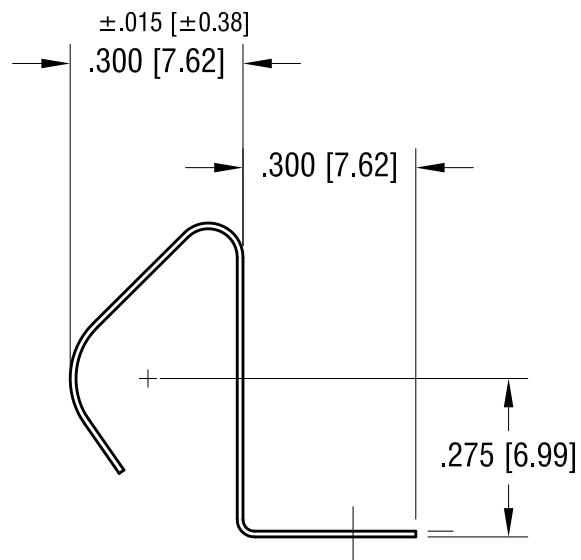
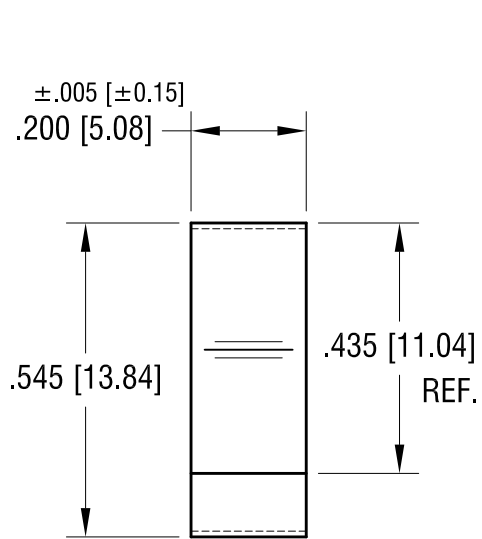

NOTE:
1. HEAT TREAT TO SPRING TEMPER.

KEYSTONE ELECTRONICS CORP.			
www.keyelco.com • NEW HYDE PARK, NY 11040 • Tel (516) 328-7500			
PART NAME			
BATTERY CONTACT, SURFACE MOUNT			
MATERIAL			
.010 [0.25] TH'K ANNEALED SPRING STEEL			
FINISH		DRN BY	DATE
TIN NICKEL PLATE		BOONE	3.16.98
		APP'D	SCALE
		RH	3X
TOLERANCES	INCH [MM]	CODE	DWG NO.
DECIMAL	±.010 [±0.25]	C	5231
ANGULAR	± 1°		
UNLESS OTHERWISE SPECIFIED			

8.17.04	CHANGE AS PER ECN 04-058	D
DATE	DESCRIPTION	REV.