

**SB6100 MANUAL**  
**INDUSTRIAL SHOCK-BLOCK**  
**REVISION 1-H-032618**



Copyright © 2018 by Littelfuse, Inc.

All rights reserved.

This page intentionally left blank.

## TABLE OF CONTENTS

SECTION	PAGE
<b>1 Introduction</b> .....	1
1.1 General .....	1
1.1.1 SB6100 GFCI .....	1
1.1.2 SB6100 EGFPD .....	2
1.2 Features .....	2
1.3 Operator Interface (AC6000-OPI-00) .....	2
<b>2 Installation</b> .....	2
2.1 Mounting .....	2
2.1.1 Open-Chassis Models (SB6100-XX0-0) .....	2
2.1.2 Enclosed Models (SB6100-XX1-0) .....	2
2.2 Supply Connections .....	2
2.3 Load Phase Connections .....	2
2.4 Ground Connections .....	3
2.5 Load-Ground-Connection Monitor .....	3
2.6 Auxiliary Contactor Terminals .....	3
<b>3 Operation and Setup</b> .....	11
3.1 Operator Interface (AC6000-OPI-00) Buttons .....	11
3.1.1 Test/Stop .....	11
3.1.2 Reset/Start .....	11
3.2 Operator Interface LED Indication .....	11
3.2.1 Power .....	11
3.2.2 Enabled .....	11
3.2.3 Ground Leakage .....	11
3.2.4 Trip .....	11
3.3 Settings .....	11
3.4 Input Connection .....	11
3.5 Undervoltage and Chatter Detection .....	12
3.6 Contactor Monitoring .....	12
3.7 Ground-Fault Detection .....	12
3.8 Momentary Power Loss and Brown-out Detection .....	12
3.9 Load-Ground-Connection Monitor .....	12
3.10 UL 943 Self-Test and UL 1998 Requirements .....	12
<b>4 UL 943C Requirements</b> .....	13
4.1 Trip Time .....	13
4.2 Grounding Circuit .....	13
4.3 Grounding Monitor/Interrupter .....	14
<b>5 Troubleshooting</b> .....	15
<b>6 Accessories</b> .....	15
<b>7 Technical Specifications</b> .....	19
7.1 SB6100 .....	19
7.2 AC6000-CART .....	21
7.3 AC6000-MNT .....	21
<b>8 Ordering Information</b> .....	21
<b>Appendix A SB6100 Revision History</b> .....	22

## LIST OF FIGURES

FIGURE	PAGE
1 UL GFCI Classes .....	1
2 Three-Phase Connection Diagram (GFCI Configuration Shown) .....	4
3 SB6100-311-0 Enclosed Model (Lid not shown) .....	5
4 Open-Chassis Model (SB6100-310-0) Outline and Mounting Details .....	6
5 Enclosed Model (SB6100-311-0) Outline and Mounting Details .....	7
6 SB6100 Operator Interface (AC6000-OPI-00) Outline and Mounting Details .....	8
7 SB6100 Operator Interface (AC6000-OPI-00) Faceplate .....	8
8 Enclosed Model (SB6100-XX1-0) Bottom View, Terminal Block Locations .....	9
9 1N5339B Zener-Diode and SE-TA6-SM Termination Devices .....	9
10 SE-TA6 Termination Assembly .....	10
11 SE-TA6ASF-WL Small-Format Termination Assembly with Wire Leads .....	10
12 Self-Test Failure Indication .....	12
13 SB6100 Temperature Derating Curve .....	13
14 Class-A GFCI Curve .....	14
15 Class-C and -D GFCI Curve .....	14
16 AC6000-CART-00 Outline .....	16
17 AC6000-MNT-00 Outline .....	17
18 AC6000-CART with SB6100 Installed .....	18

## LIST OF TABLES

TABLE	PAGE
1 Operation of Ground Leakage LED's .....	11
2 Power and Trip Status LED's .....	11
3 Status LED Troubleshooting .....	15

## DISCLAIMER

Specifications are subject to change without notice. Littelfuse Startco is not liable for contingent or consequential damages, or for expenses sustained as a result of incorrect application, incorrect adjustment, or a malfunction.

This page intentionally left blank.

## 1 INTRODUCTION

### 1.1 GENERAL

The SB6100 Industrial Shock-Block is available as a special-purpose ground-fault circuit interrupter (SPGFCI) or as an equipment ground-fault protective device (EGFPD). Both types operate within the time-current curve defined by UL 943 and CSA C22.1 for Class A GFCI's.

The SB6100 is available in open-chassis or enclosed models for voltages from 208 to 600 V. All SB6100 models are continuously-rated at 100 A and include overcurrent protection through Littelfuse Class T fuses. Enclosed models have a NEMA-4X rating and are UL-listed. The open-chassis models are UL-recognized for installation by an original equipment manufacturer.

GFCI models have a fixed trip-level setting of 20 mA and are UL 943C listed (enclosed) or UL 943C recognized (open chassis). EGFPD models have adjustable trip-level settings from 6 to 100 mA, and are UL 943 and UL 1053 listed (enclosed), or UL 943 and UL 1053 recognized (open chassis). All models are certified by CSA to C22.2 No. 144-M91.

Each SB6100 includes an AC6000-OPI-00 Operator Interface with status-indication LED's and control buttons.

SB6100's are rated for use as a motor controller.

definitions for Class C and Class D devices, with a fixed 20-mA trip level. These classes extend GFCI protection beyond the standard 6-mA Class-A GFCI and are appropriate for many industrial and commercial applications.

Special-purpose SB6100 GFCI's (Class C or Class D) can be used in the following applications:

- 3-Phase Grounded-neutral systems where voltage to ground is above 150 Vac and equipment grounding or double insulation is required by the National Electrical Code (NEC) and ANSI/NFPA 70.
- 3-Phase Grounded-neutral systems where voltage to ground is 150 Vac or less and equipment grounding or double insulation is provided, but the use of a Class A ground-fault circuit interrupter is not practical.
- Any 3-Phase CEC application in which a Class A GFCI is not required.

The UL GFCI classes and their intended applications are shown in Fig. 1.

The SB6100 also provides ground-connection monitoring as required by UL 943C. The ground-monitoring function automatically disconnects the supply if the load is not properly bonded to ground, and requires a cable pilot wire and a termination device installed at the load. The SB6100 will not allow its contactor to close on power-up and will open the contactor if the load ground is not connected. See Fig. 2.

#### 1.1.1 SB6100 GFCI

GFCI models are permanently-connected special-purpose GFCI's that meet the requirements of UL 943C

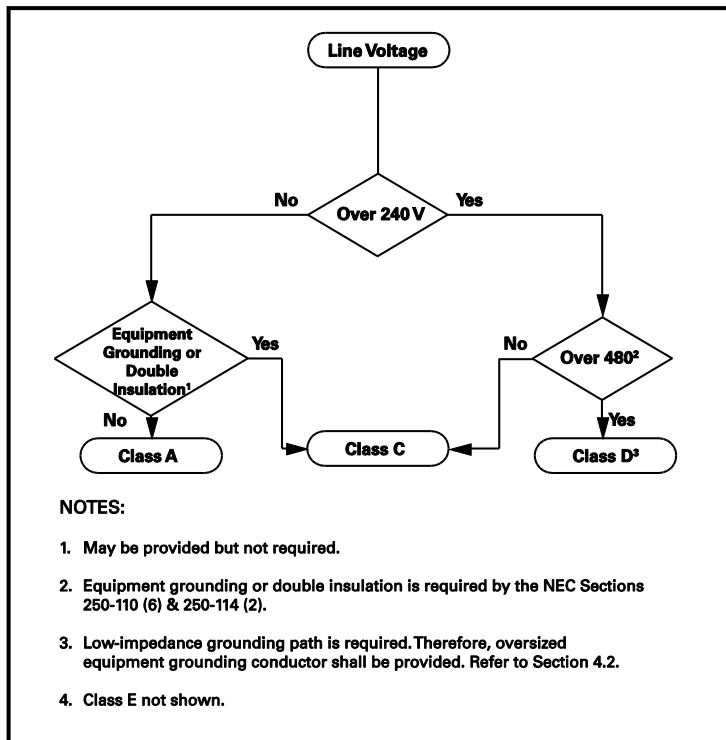

FIGURE 1. UL GFCI Classes.

### 1.1.2 SB6100 EGFPD

EGFPD models can be set to trip at 6 mA or from 10 to 100 mA in increments of 10 mA, and meet the requirements of UL 943 and UL 1053. All models are certified by CSA to C22.2 No. 144-M91. The adjustable trip level can help prevent nuisance tripping in some applications.

If required by the application, a load-ground-connection monitor feature can be enabled for EGFPD models. See Section 2.5.

### 1.2 FEATURES

- UL 943 inverse time curve reduces the probability of nuisance tripping.
- UL 943C fixed trip level (GFCI models) provides protection for systems with leakage current higher than the 6-mA trip level required by Class A GFCIs.
- Selectable trip levels (EGFPD models) help reduce nuisance tripping by allowing users to adjust the trip level in systems that have leakage current higher than UL 943 Class A 6-mA trip level, or UL 943C Class C or D 20-mA trip level.
- UL 943C ground-connection monitoring ensures continuity of the load ground.
- Undervoltage, brown-out and chatter detection prolong the internal contactor lifetime.
- Overcurrent protection is provided with three 200 A, 600 V Class T fuses.
- Can be used as a motor or pump starter.
- Meets UL 1998 requirements.
- Self-test feature continuously monitors hardware to ensure safe operation.
- Uses patented technology.
- Conformally coated circuit boards.

### 1.3 OPERATOR INTERFACE (AC6000-OPI-00)

- LED status indication
- Power (PWR) and Enabled (EN) indicators
- Ground Leakage indicators (25%, 50%, 75%, and 100%)
- Fault (FLT), Input Connection (INP), and Load Ground Connection (GC) indicators
- Test/Stop and Reset/Start buttons

## 2. INSTALLATION

The SB6100 is considered to be a permanently mounted GFCI/EGFPD and should be attached to a wall or other suitable mounting surface.

The connection diagram for three-phase systems is shown in Fig. 2. Ensure that all conductors have the required voltage and current ratings necessary for the application. SB6100 installation should be performed by a qualified person.

## 2.1 MOUNTING

### 2.1.1 OPEN-CHASSIS MODELS (SB6100-XX0-0)

Open-chassis models are to be mounted in a suitable enclosure for the intended environment. Follow the IP or NEMA guidelines for the required enclosure type. Install in the correct orientation as shown in Fig. 4, and refer to the ‘This Side Up’ label attached to the side of the chassis.

Open-chassis models include an Operator Interface (AC6000-OPI-00) and 3 m of cable.

The AC6000-OPI-00 should be mounted from the back side of a panel. Prepare a mounting cut-out as shown in Fig. 6. For a water-resistant installation, ensure that the supplied gasket makes suitable contact with the panel. Secure with eight 4-40 machine screws and hex nuts. If it is desired to have a flush install, use flat-head machine screws and countersink the holes as shown in Fig. 6. Attach the supplied cable to the SB6100 15-pin connector labeled OPI, securing with the supplied screws, and to the AC6000-OPI-00, ensuring that the connector locks into place. Secure the cable with cable ties.

### 2.1.2 ENCLOSED MODELS (SB6100-XX1-0)

Install enclosed models in the correct orientation as shown in Fig. 5, and refer to the ‘This Side Up’ label attached to the side of the enclosure.

Enclosed models ship with no cable entry points predrilled. An appropriate hole or holes must be made in the enclosure and fitted with NEMA-4X-rated fittings for the installation of all conductors. Space is left near the bottom of the enclosure to install the wiring. See Figs. 3 and 8.

## 2.2 SUPPLY CONNECTIONS

The supply phases are marked Input 1, 2, and 3 on the base of the chassis as shown in Fig. 3. Use a 5/16” hex (Allen) key to tighten the input connections. Torque the input terminals as described in Section 7. The input terminals will accept 14 to 2/0 AWG (2.08 to 67.4 mm<sup>2</sup>) conductors.

## 2.3 LOAD PHASE CONNECTIONS

The load phases are marked Output 1, 2, and 3 on the base of the chassis as shown in Fig. 3. Use a 3/16” hex (Allen) key to tighten the output connections. Torque the output terminals as described in Section 7. The output terminals will accept 14 to 2/0 AWG (2.08 to 67.4 mm<sup>2</sup>) conductors.

## 2.4 GROUND CONNECTIONS

Connect the supply and load ground conductors to the chassis bonding point ( $\perp$ ) as shown in Fig. 3. Use a flat-blade screwdriver to tighten the ground connections. Torque the ground terminals as described in Section 7. The ground terminals will accept 14 to 1/0 AWG (2.08 to 53.5 mm<sup>2</sup>) conductors.

## 2.5 LOAD-GROUND-CONNECTION MONITOR

An insulated pilot wire from the SB6100 to the load, and a termination device located at the load are required to monitor the load-ground connection. Total pilot wire and ground wire resistance must be less than 38 ohms. Outline dimensions and mounting details for compatible termination devices are shown in Figs. 9, 10, and 11.

This monitoring function is required for GFCI models installed in NEC applications, and can be implemented if desired for EGFPD models.

Use only a Littelfuse Startco termination device as others may not meet performance requirements. Each SB6100 GFCI is supplied with a 1N5339B termination device. Install the termination device at the load to complete the ground-connection loop as shown in Fig. 2. Connect terminal G of the termination device to the equipment frame so that the ground-conductor-to-equipment-frame connection will be included in the monitored loop. Connect terminal GC to the pilot wire and connect the pilot wire to the SB6100 terminal GC as shown in Figs. 2 and 3.

EGFPD models include a 1N5339B termination device installed at the GC terminal. The termination device should remain installed at the GC terminal if the load-ground-connection monitoring feature is not required.

## 2.6 AUXILIARY CONTACTOR TERMINALS

An auxiliary normally-open contact (labeled AUX) is provided on all models. This contact, rated at 4 A, 240 Vac, follows the state of the internal contactor. See Figs. 2 and 3.

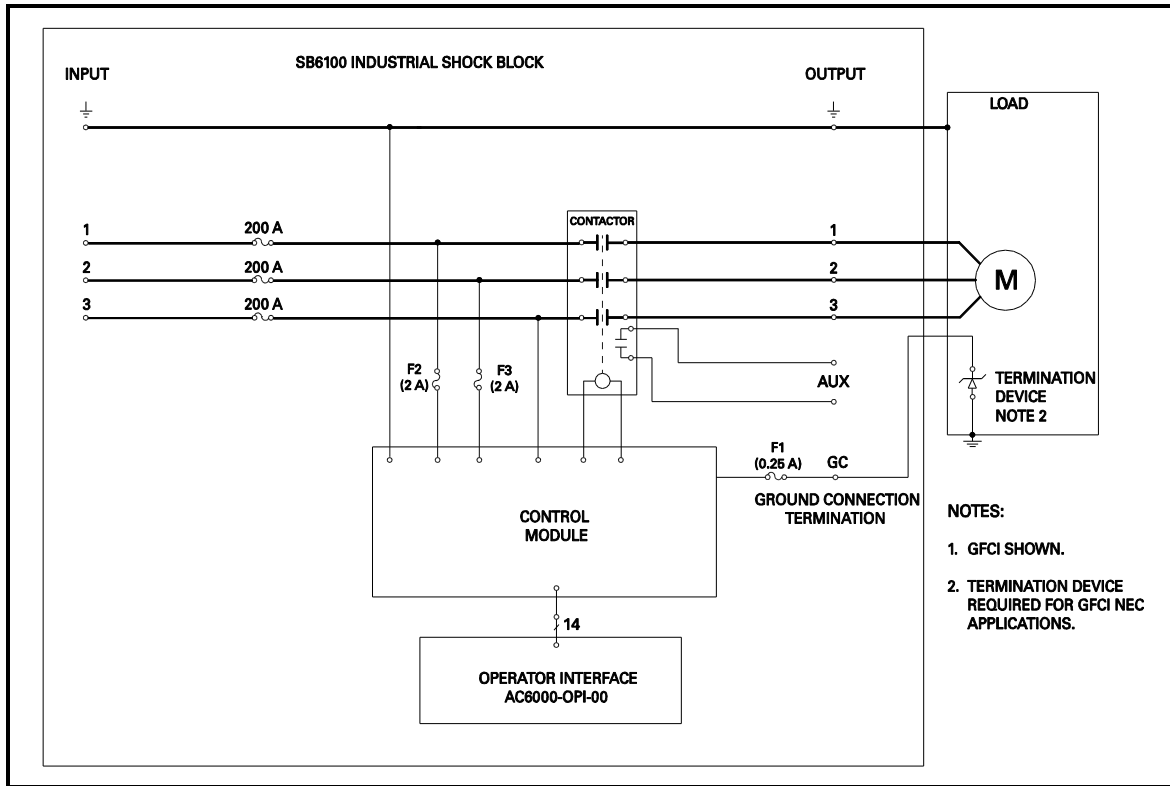

FIGURE 2. Three-Phase Connection Diagram (GFCI Configuration Shown).



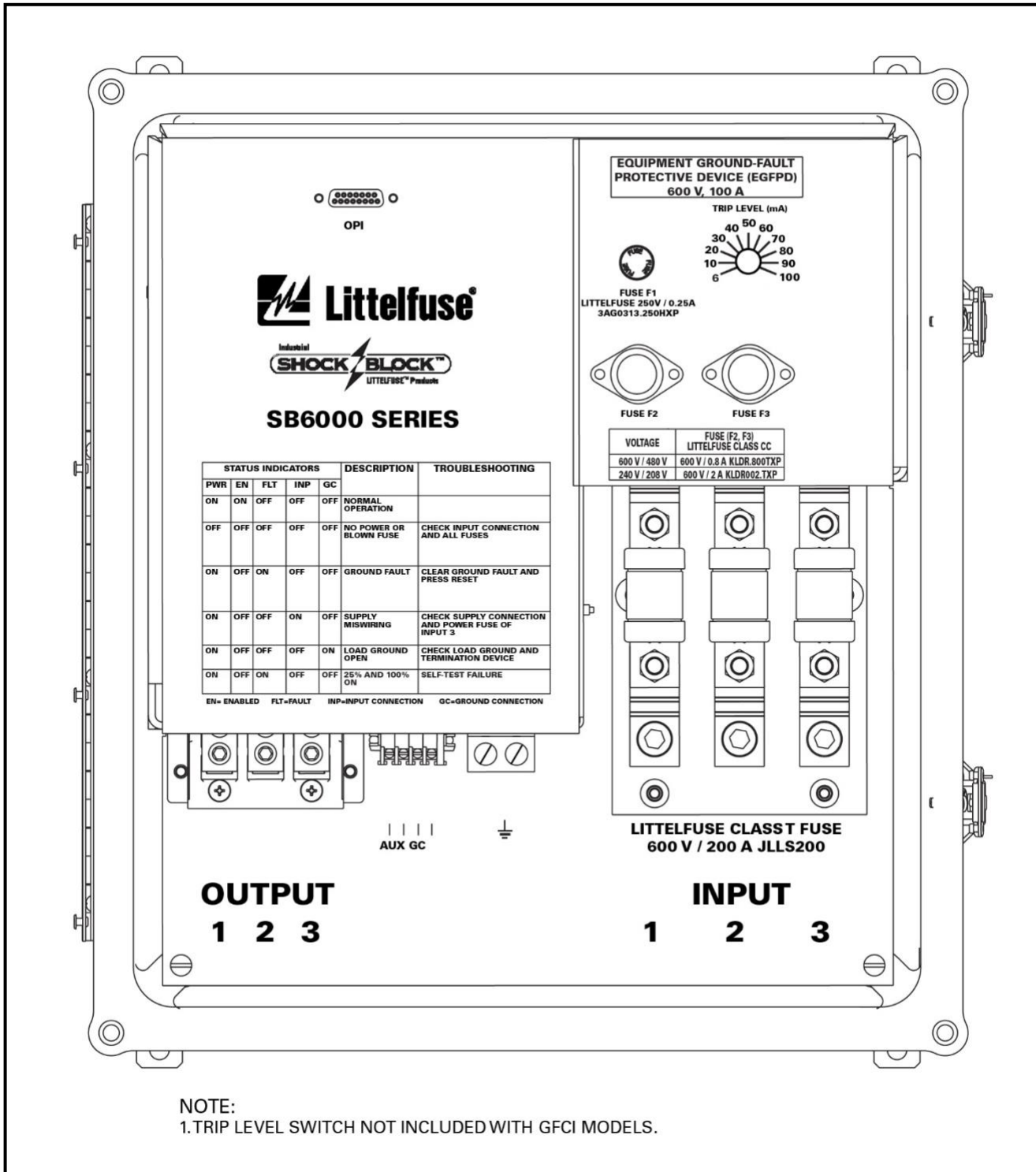

FIGURE 3. SB6100-311-0 Enclosed Model (Lid not shown).



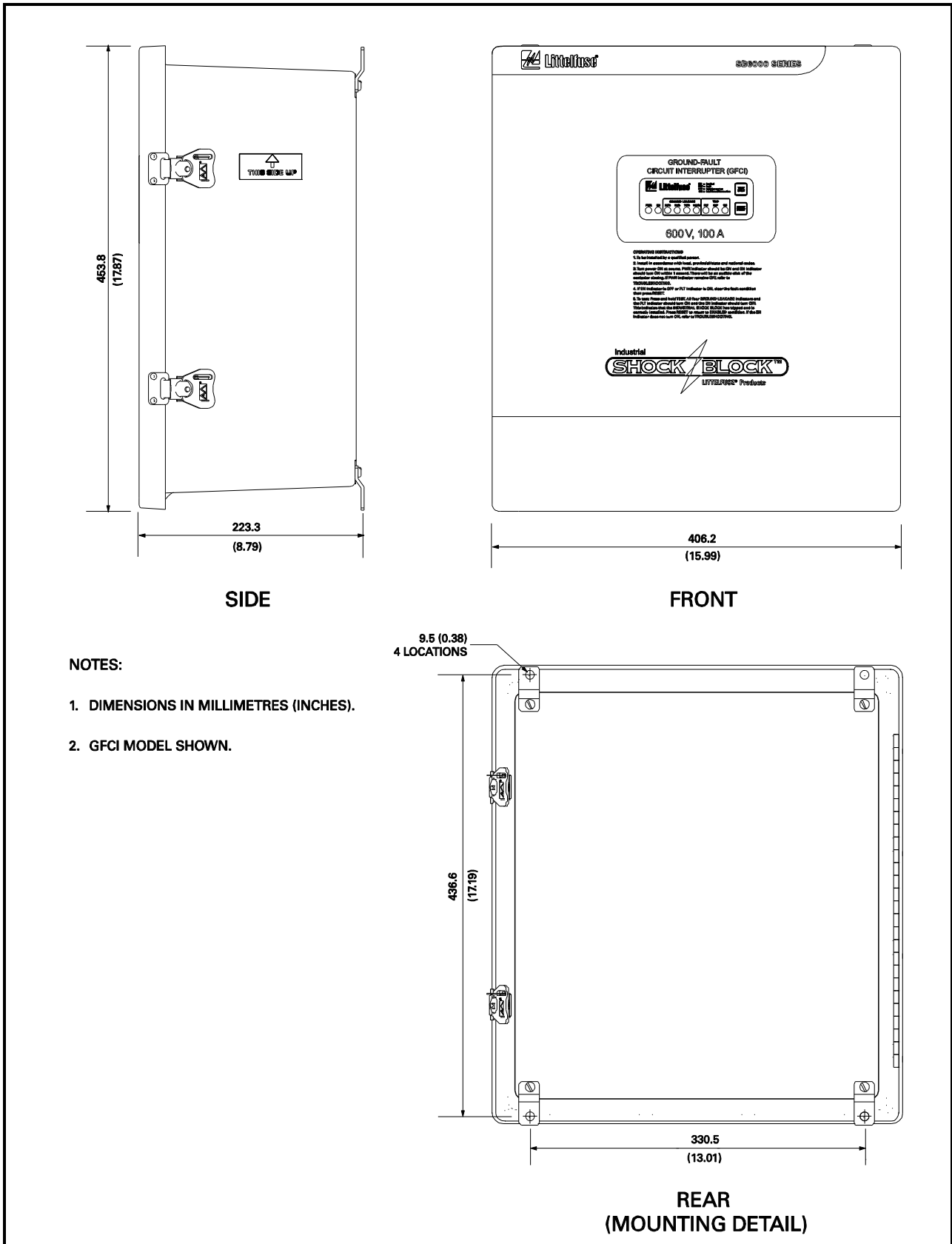

FIGURE 5. Enclosed Model (SB6100-311-0) Outline and Mounting Details.

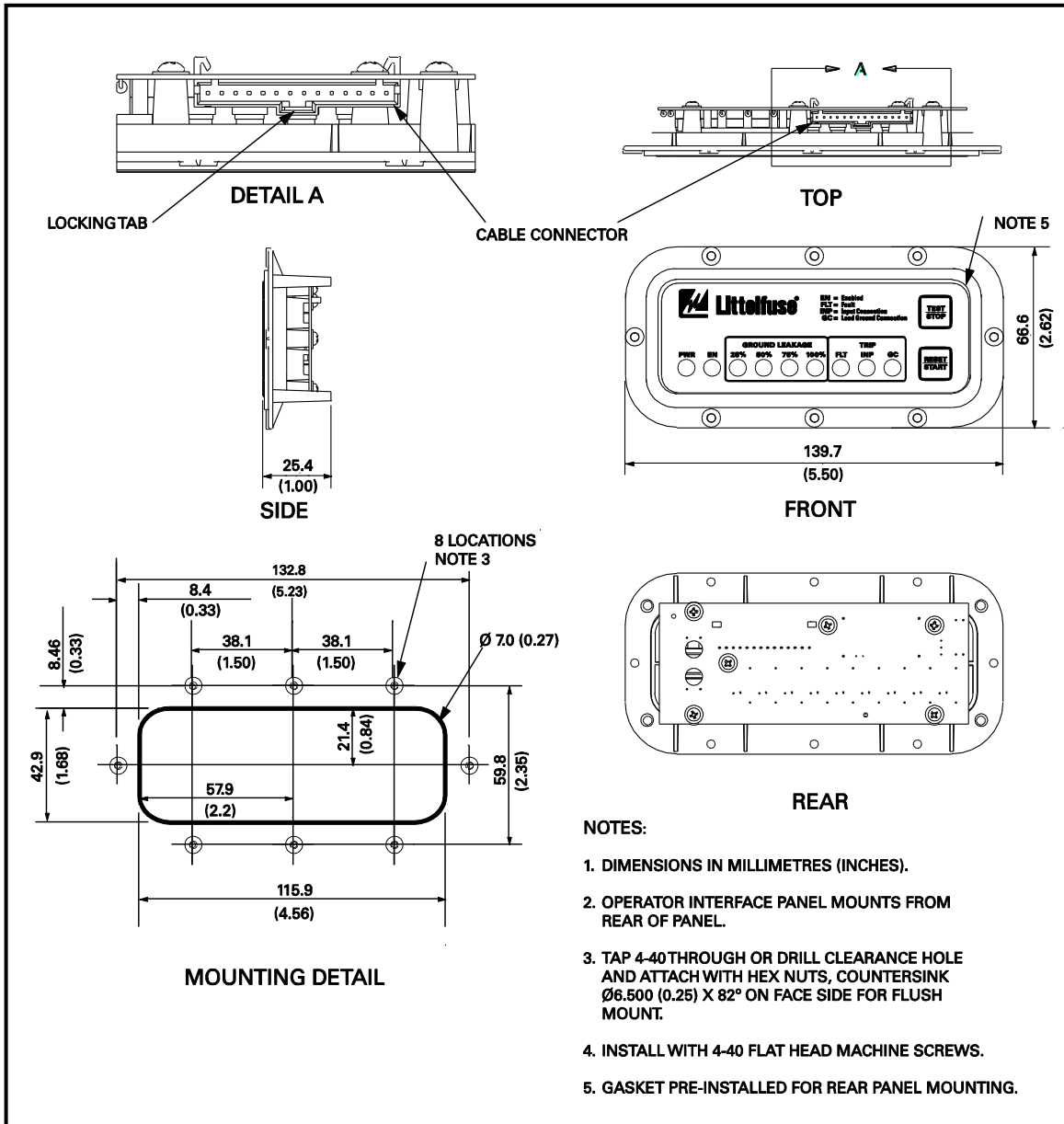

FIGURE 6. SB6100 Operator Interface (AC6000-OPI-00) Outline and Mounting Details.

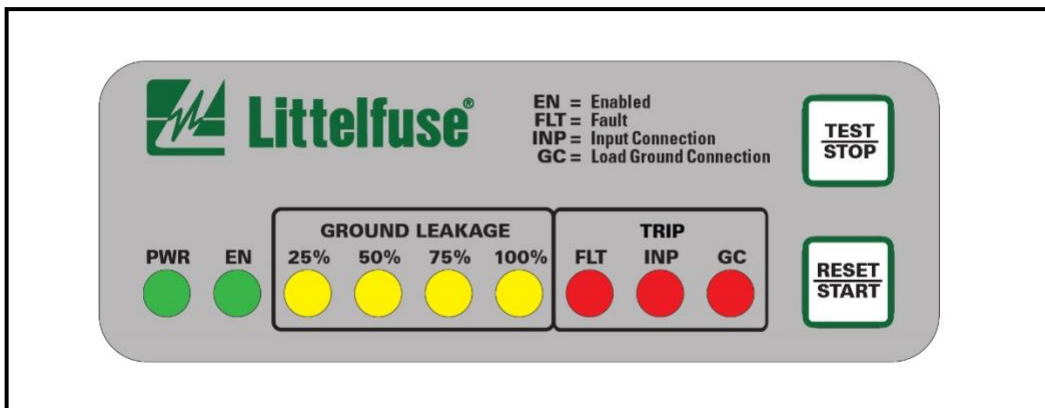

FIGURE 7. SB6100 Operator Interface (AC6000-OPI-00) Faceplate.

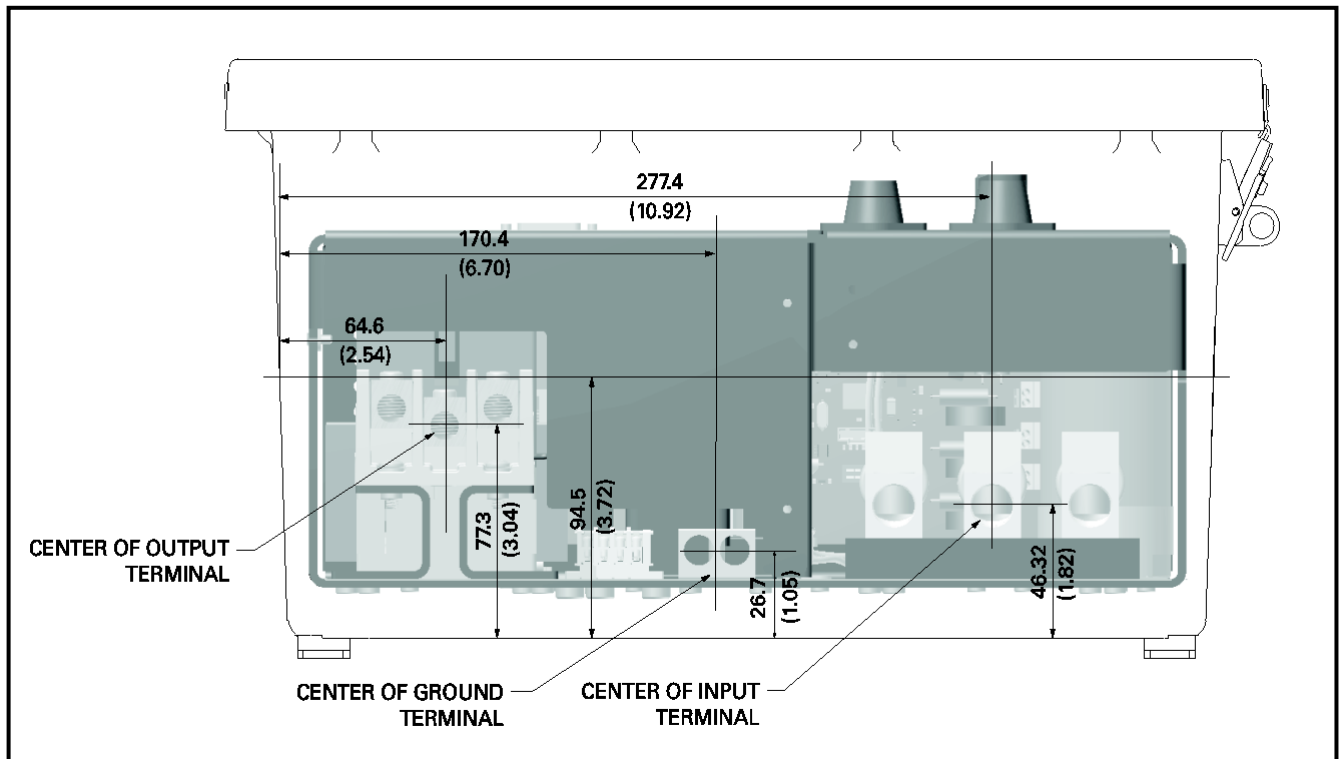

FIGURE 8. Enclosed Model (SB6100-XX1-0) Bottom View, Terminal Block Locations.

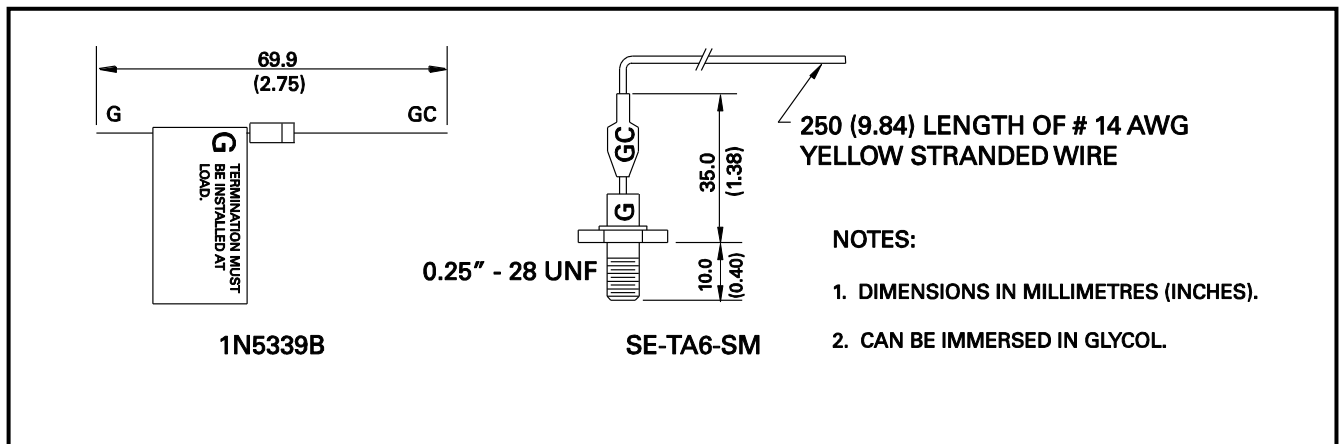

FIGURE 9. 1N5339B Zener-Diode and SE-TA6-SM Termination Devices.

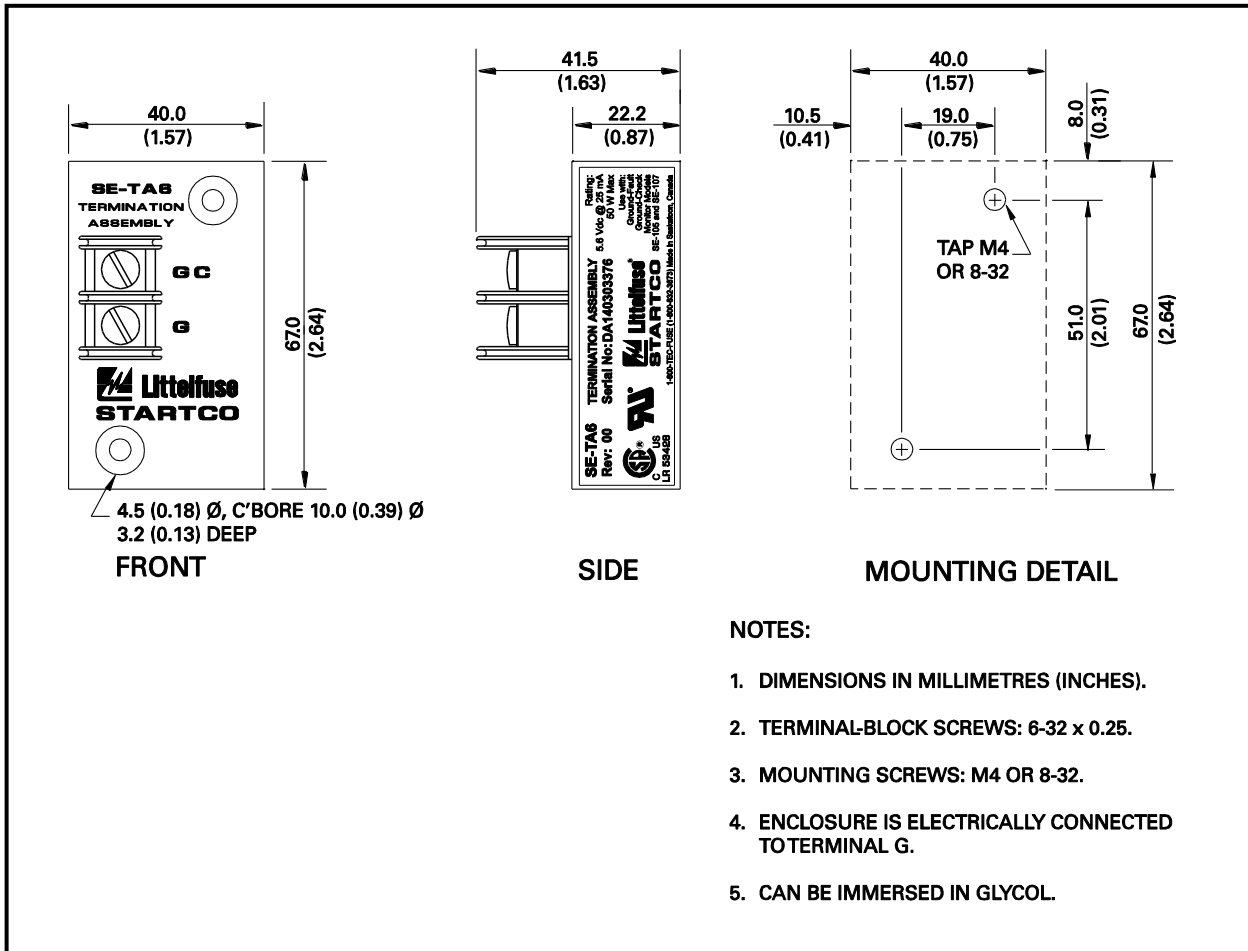

FIGURE 10. SE-TA6 Termination Assembly.

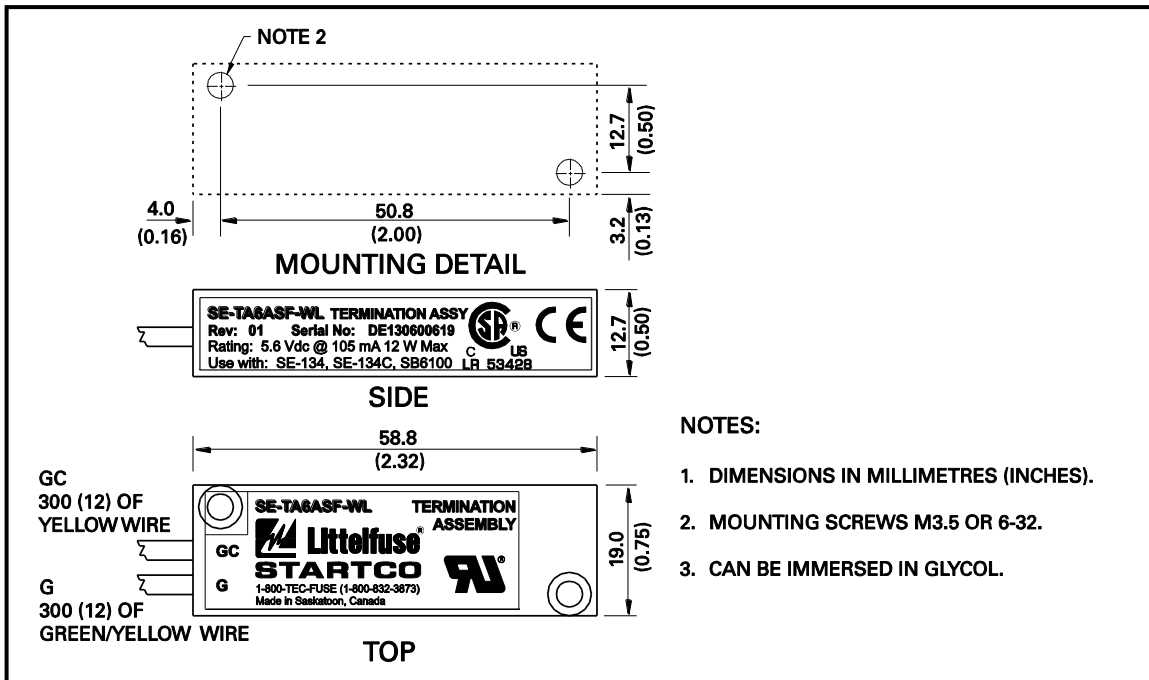

FIGURE 11. SE-TA6ASF-WL Small-Format Termination Assembly with Wire Leads.

### 3. OPERATION AND SETUP

**NOTE:** When its input terminals become energized, the SB6100 powers up in RESET/START mode and the connected circuit will be energized after a brief system test.

The operator interface (AC6000-OPI-00) provides indication and control for the SB6100. The AC6000-OPI-00 has nine LED's and two buttons (TEST/STOP and RESET/START). The LED's indicate power (PWR), output state (EN), ground leakage (25%, 50%, 75%, and 100%), and trip status (FLT, INP, and GC). See Figs. 6 and 7.

#### 3.1 OPERATOR INTERFACE (AC6000-OPI-00) BUTTONS

##### 3.1.1 TEST/STOP

The TEST/STOP button is used to de-energize the load and to test the SB6100 ground-fault detection circuit, indication, and contactor. When the TEST/STOP button is pressed for one second, all four Ground Leakage LED's and the FLT LED will turn ON, the EN LED will turn OFF, and the SB6100 will trip.

##### 3.1.2 RESET/START

The RESET/START button is used to reset the SB6100 after a ground fault has occurred and to energize the load. When the RESET/START button is momentarily pressed and there are no fault conditions present, the contactor will close and the enable (EN) LED will be ON. If the SB6100 trips immediately after a reset, a ground fault is still present.

#### 3.2 OPERATOR INTERFACE LED INDICATION

##### 3.2.1 POWER

The green LED labeled PWR indicates the presence of supply voltage.

##### 3.2.2 ENABLED

The green LED labeled EN indicates that the contactor is closed. An audible sound from the internal contactor can be heard each time the contactor opens or closes.

When supply voltage is applied to the SB6100, the SB6100 closes the contactor after a three-second delay, if there are no fault conditions present.

##### 3.2.3 GROUND LEAKAGE

The four yellow GROUND LEAKAGE LED's indicate the presence of ground-leakage current at 25, 50, 75 and 100% of the trip level. For an EGFPD, the trip level can be selected from 6 to 100 mA. For a GFCI, the trip level is fixed at 20 mA. Table 1 describes the operation of the ground-leakage LED's.

TABLE 1. OPERATION OF GROUND LEAKAGE LED'S.

LED	STATE	DESCRIPTION
25%	ON	Current $\geq$ 25% of Trip Level
50%	ON	Current $\geq$ 50% of Trip Level
75%	ON	Current $\geq$ 75% of Trip Level
100%	ON	Current $\geq$ 100% of Trip Level
25 & 100% ONLY	ON	Self-Test Failure. See Section 3.10.

**NOTE:** Ground leakage indication is approximate.

##### 3.2.4 TRIP

Three red trip LED's provide detailed trip indication.

If the FLT LED is on, the unit has tripped. One or more conditions may have caused a trip. If the FLT LED is flashing, the SB6100 has detected a brown-out or chattering condition. See Table 2 and Sections 3.5 and 3.6.

If the INP LED is on, the supply wiring is not connected properly. See Section 3.4. If the INP LED is flashing, the SB6100 has detected a supply undervoltage condition. See Table 2 and Section 3.5.

If the GC LED is on, the load ground is not connected. See Table 2 and Section 3.9.

TABLE 2. POWER AND TRIP STATUS LED'S.

LED	STATE	DESCRIPTION
PWR	ON	Unit Powered
	OFF	Unit Not Powered
EN	ON	Load Connected
	OFF	Load Not Connected
FLT	ON	Unit Tripped
	OFF	Unit Not Tripped
	Flash	Contactor Drop-Out Due to a Brown-Out or Chattering Condition
	ON*	Self-Test Failure. See Section 3.10.
INP	ON	Supply Miswiring
	OFF	Supply Connected Properly
	Flash	Input Undervoltage
GC	ON	Load Ground Not Connected
	OFF	Load Ground Connected (when used)

\* 25% & 100% Ground Leakage LED's also on.

#### 3.3 SETTINGS

The GFCI model has a fixed 20-mA trip-level value.

The EGFPD model can be set to trip at 6 mA, or from 10 to 100 mA in increments of 10 mA. The TRIP LEVEL (mA) rotary selection switch is located on the chassis front panel. See Figs. 3 and 4.

#### 3.4 INPUT CONNECTION

The input supply connection is checked for correct wiring during power-up. The red Input Connection (INP) LED will be on and the SB6100 will not close the contactor if any of the following conditions are present:

- Input 3 is not connected
- Input 3 fuse is open
- Supply ground is open

After the SB6100 input supply connection is corrected, the SB6100 will automatically close the contactor if no other fault conditions are detected.

**NOTE:** SB6100 electronics are supplied from input phases 1 and 2. If either phase is not connected, the unit will remain off with the contactor open.

**NOTE:** The input connection is checked for correct wiring only during power-up. Accordingly, if Input 3 or the supply ground opens during normal operation, the SB6100 will not detect an input supply connection problem.

### 3.5 UNDERVOLTAGE AND CHATTER DETECTION

The input voltage is always checked before the contactor is closed. If an input undervoltage condition is detected, the contactor will remain open and the red INP LED will flash every second. The control circuit will continuously check the input voltage and will close the contactor when the input voltage is within acceptable limits.

Undervoltage detection is provided to prolong the lifetime of the contactor by preventing contactor chatter. Contactor chatter occurs when the voltage applied to the control coil is marginally lower than the minimum pull-in voltage.

### 3.6 CONTACTOR MONITORING

The SB6100 continuously monitors the state of the contactor. If an incorrect state is detected, the FLT LED will flash every second, the contactor will open and will remain open until supply voltage to the unit is cycled. This condition should never be encountered during normal operation.

The SB6100 should be used within the specifications listed in Section 7 to ensure correct operation.

**NOTE:** At room temperature, the minimum contactor pull-in voltage is approximately 80% of the nominal voltage. At higher temperatures, the minimum pull-in voltage is higher than 80% of the nominal voltage.

### 3.7 GROUND-FAULT DETECTION

The red Fault (FLT) LED indicates a ground-fault trip. The SB6100 will remain tripped until the RESET/START button is pressed or supply voltage is cycled. See Section 3.1.2.

### 3.8 MOMENTARY POWER LOSS AND BROWN-OUT DETECTION

When supply voltage to the SB6100 is removed, the contactor will open and the green PWR and EN LED's will turn off. For a short supply outage of approximately

20 seconds, the SB6100 will remain powered-up and retain its state prior to the outage (either energized or tripped). For longer supply outages, the SB6100 will power-up in an untripped state.

In the case of a brown-out condition where the input voltage dips too low, the contactor will open and the red FLT LED will flash every second. The SB6100 will remain in a tripped state until RESET/START is pressed. Before pressing RESET/START, ensure the input voltage is within the acceptable range.

**NOTE:** At 25°C (77°F), the contactor drop-out voltage level is approximately 60% of the nominal supply voltage. At higher temperatures, the contactor drop-out voltage is higher than 60% of the nominal voltage.

### 3.9 LOAD-GROUND-CONNECTION MONITOR

The Load-Ground-Connection Monitor (GC) LED indicates that the load ground is open. If the load ground connection is not connected during power-up or becomes disconnected during normal operation, the GC LED will turn ON and the contactor will open.

The SB6100 continuously monitors the load ground and will automatically close the contactor if the load-ground connection is restored.

**NOTE:** Load-ground-connection monitoring is only required for GFCI models as per UL 943C. Refer to Section 4.3 for a description of the UL 943C load-ground monitor requirements. For EGFPD models, load-ground-connection monitoring is optional.

### 3.10 UL 943 SELF-TEST AND UL 1998 REQUIREMENTS

The 2015 revision to the UL 943 standard includes a self-test requirement to verify a GFCI's ability to respond to a ground fault. All SB6100 options (revision 01 or newer) include an automatic self-test feature. If a problem is detected, the SB6100 will trip. A Self-Test Failure will be indicated by a unique LED pattern as shown in Fig. 12.

A self-test is initiated a few seconds after power-up, a few seconds after the contactor is closed, and hourly during normal operation. A self-test may be indicated by a brief flash of one or several ground-leakage LED's.

In addition to the automatic self-test, a monthly manual test is also recommended.

Compliance to the UL 1998 Software in Programmable Components standard is also included.

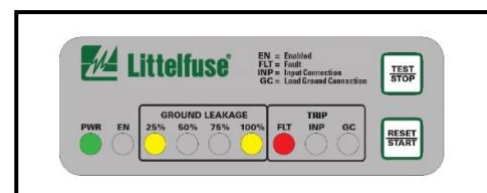

FIGURE 12. Self-Test Failure Indication.



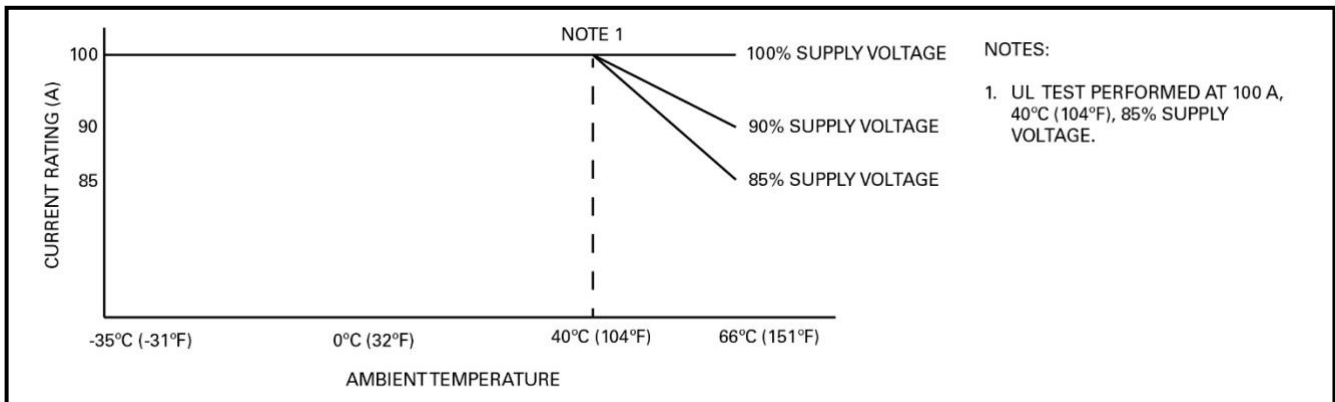

FIGURE 13. SB6100 Temperature Derating Curve.

#### 4. UL 943C REQUIREMENTS

The following sections contain excerpts from the UL 943C<sup>(1)</sup> Standard for Class C and D applications. For EGFPD models, only Section 4.1 applies where selectable trip levels from 6 to 100 mA are permitted (20 mA is the only allowed trip level for GFCI devices in NEC applications).

##### 4.1 TRIP TIME

Class C and Class D GFCI's shall be capable of interrupting the electric circuit to the load when the fault current to ground (*I*) is within the range of a minimum of 20 mA through a maximum of (110% of the rated voltage/500 Ω) A within the time interval (*T*) in accordance with the relationship:

$$T = \left( \frac{20}{I} \right)^{1.43}$$

Where:

*T* is expressed in seconds, and  
*I* is expressed in mA

Except that *T* is not required to be less than 20 ms.

The tripping threshold of these GFCI's shall be in the range of 15 to 20 mA.

Fig. 14 shows the Class-A GFCI maximum-trip-time-versus-current curve defined by UL 943 (with the above formula); UL943 also defines a limit to the formula, with a minimum required trip time (or fastest trip speed) of 20 ms, which occurs at about 300 mA of ground-fault current (*I*) per the formula. Class C and D GFCI's must operate within this same curve, except that their operating threshold is 15 to 20 mA (non-adjustable). See Fig. 15. The SB6100 EFGPDs described in this manual also

operate within the Class-A formula, but have a 6- to 100-mA threshold setting range.

##### 4.2 GROUNDING CIRCUIT

The equipment grounding circuit of the circuit shall be sufficiently low impedance that, should a fault to ground occur, the voltage resulting across the grounding circuit shall not exceed 150 V. The size of the grounding conductor required for a circuit shall be determined by calculating the resistance using the following formula and converting that value to a wire gauge based on the length of the equipment grounding conductor:

$$R_G = \frac{150 R_U}{V_{LG} - 150}$$

Where:

*R<sub>G</sub>* is the resistance of the equipment grounding conductor

*R<sub>U</sub>* is the resistance of the ungrounded conductor, and  
*V<sub>LG</sub>* is the RMS value of the supply line to ground voltage

Refer to UL 943C Appendix A for a sample calculation of grounding conductor size.

**4.3 GROUNDING MONITOR/INTERRUPTER**

A GFCI shall be capable of detecting and causing interruption of the circuit under both of the following conditions:

- a) An open grounding circuit, and
- b) Impedance in the grounding circuit that would allow more than a 150 volt drop in the grounding circuit.

(1) Excerpts from UL 943C are the property of Underwriters Laboratories Inc.

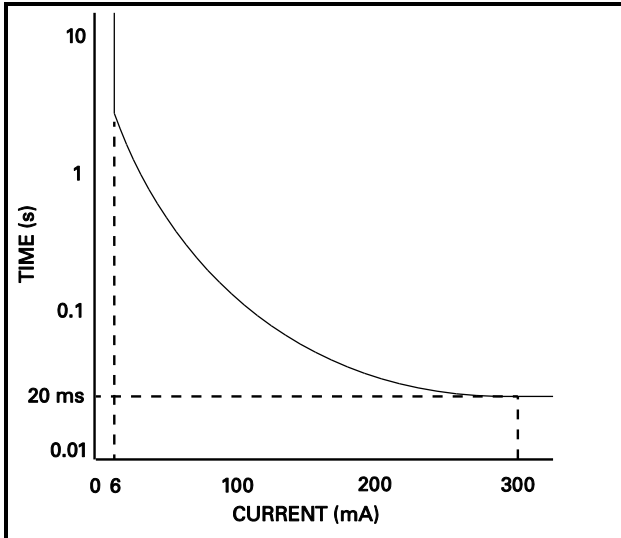

FIGURE 14. Class-A GFCI Curve.

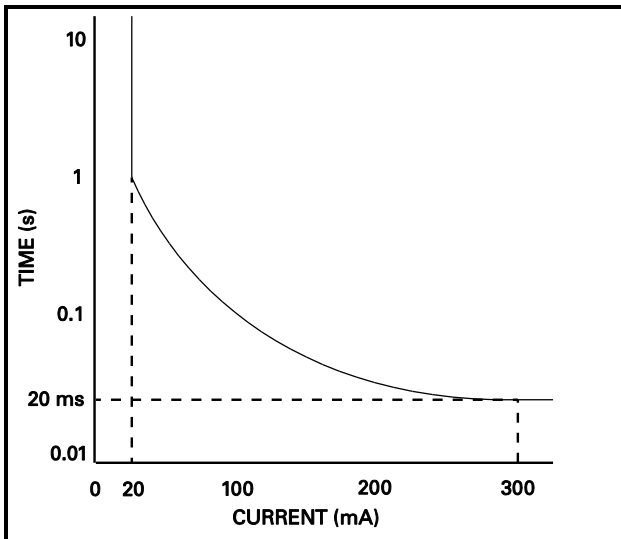

FIGURE 15. Class-C and -D GFCI Curve.

## 5. TROUBLESHOOTING

TABLE 3. STATUS LED TROUBLESHOOTING.

STATUS LED'S					DESCRIPTION	TROUBLESHOOTING
PWR	EN	FLT	INP <sup>(1)</sup>	GC		
ON	ON	OFF	OFF	OFF	Normal Operation	-----
OFF	OFF	OFF	OFF	OFF	No Power to the SB6100	Check supply connection to, and power fuses of, inputs 1 and 2, and secondary fuses F2 and F3.
ON	OFF	ON	OFF	OFF	Ground Fault Occurred	Clear ground fault on the system and press RESET/START.
ON	OFF	Flash	OFF	OFF	Contactors Drop-Out Due to a Brown-Out Condition or Chattering Condition	Verify the input voltage is within acceptable limits and press RESET/START.
ON	OFF	OFF	ON	OFF	Input Miswiring <sup>(2)</sup>	Check input connection to, and power fuse of, input 3.
ON	OFF	OFF	Flash	OFF	Input Undervoltage	Input voltage must be within acceptable limits.
ON	OFF	OFF	OFF	ON	Load-Ground Connection Open	Check load ground, pilot wire, and termination device <sup>(3)</sup> .
ON	OFF	ON	OFF	OFF	25 and 100% LED's on	Self-Test Failure <sup>(5)</sup>

### NOTES<sup>(4)</sup>:

- (1) The INP LED is shared between the miswire and undervoltage conditions. Miswiring has priority over undervoltage, i.e. if both conditions occur at the same time the INP LED will stay on, indicating a miswire until the connection is fixed, then it will flash if the undervoltage condition still exists.
- (2) Supply miswiring test is only performed on power-up.
- (3) The unit will pull in once the condition is corrected.
- (4) It is possible for two of the above conditions to occur simultaneously. In this case each respective LED will individually indicate one condition.
- (5) Hardware revision 01 or newer.

## 6. ACCESSORIES

The AC6000-CART-00 two-wheeled cart is available for enclosed models of the SB6100. The cart allows the SB6100 to be moved when not powered, and supports up to 23 kg (50 lb) of cable around the frame. The lower panel size is 457 mm (18") x 279 mm (11") and can be used as a mounting location for connectors or other accessories. See Fig. 16 and Section 7.

The AC6000-MNT-00 mounting frame is available separately. The mounting frame is shipped unassembled and includes U-bolts to fit metal tubing with a 25 mm (1") diameter. Alternate hardware (not supplied) can be used to install the mounting frame to a user-supplied cart or a wall. The frame supports up to 23 kg (50 lb) of cable around the frame. See Fig. 17 and Section 7.

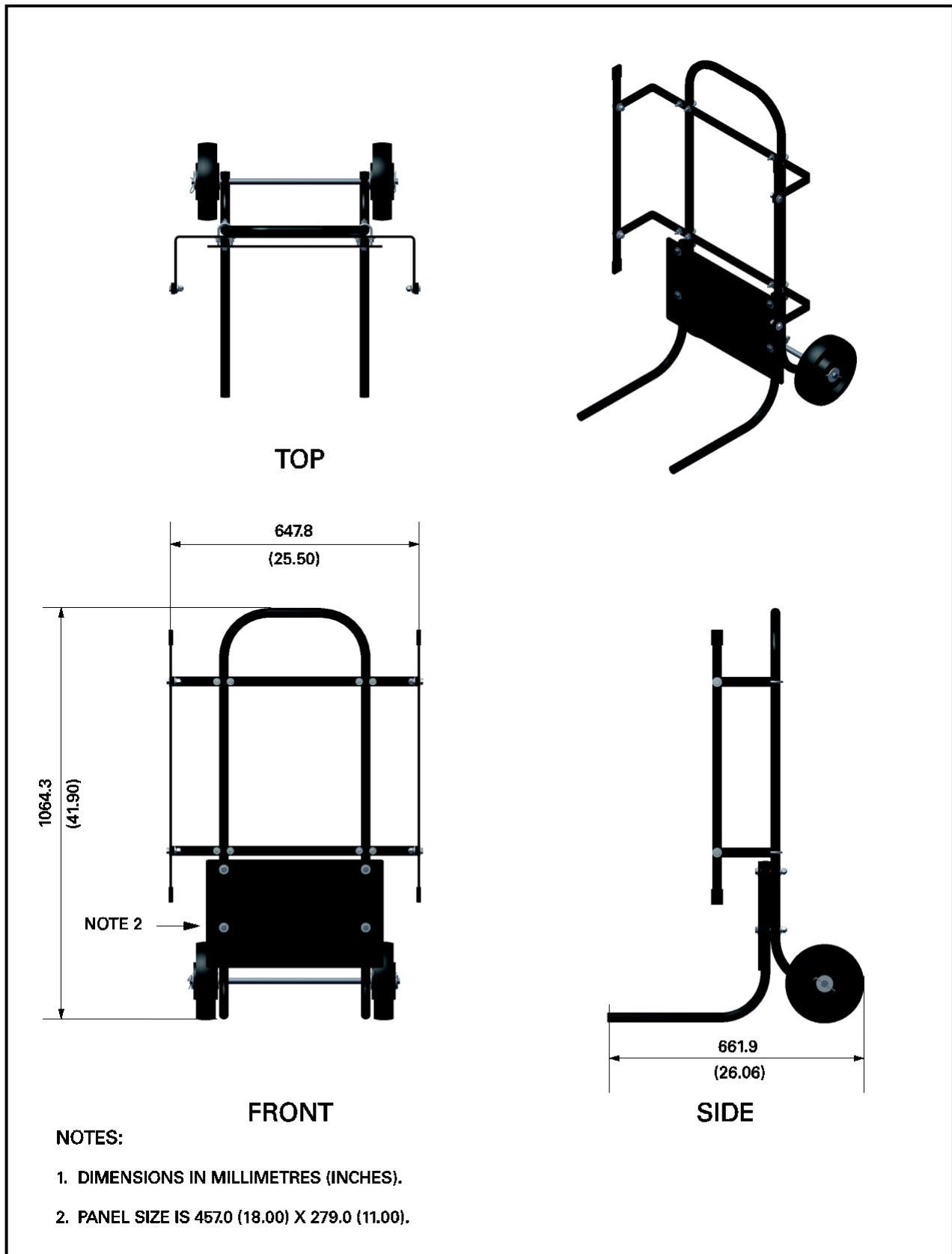

FIGURE 16. AC6000-CART-00 Outline.

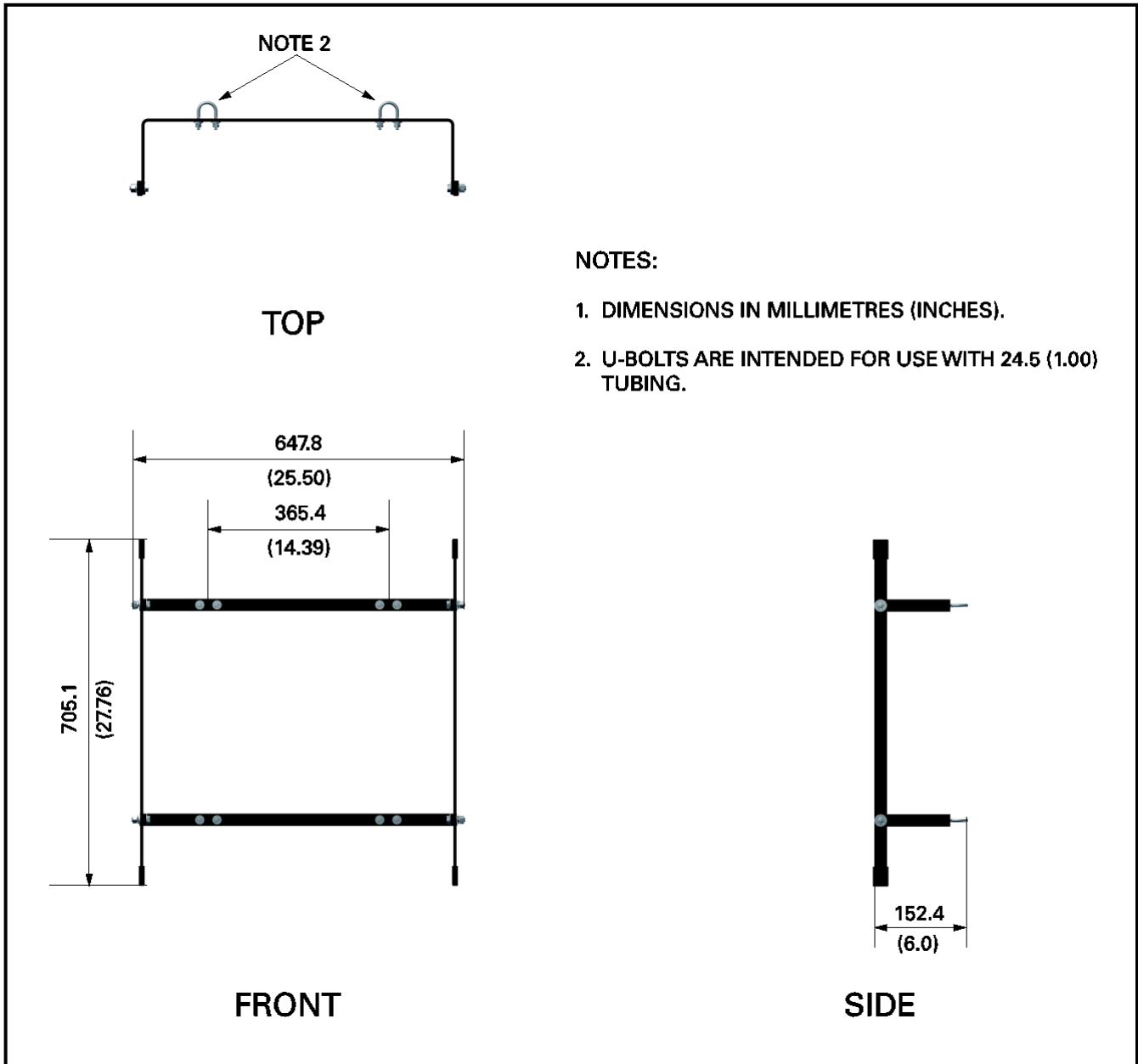

FIGURE 17. AC6000-MNT-00 Outline.



FIGURE 18. AC6000-CART with SB6100 Installed.

## 7. TECHNICAL SPECIFICATIONS

### 7.1 SB6100

Voltage, Current, and Power Ratings<sup>(1)</sup>:

Option 0:

Voltage ..... 3 PH, 3 wire (no neutral),  
50/60 Hz<sup>(2)</sup>, 208 Vac  
(+10, -15%)

Current:

AC-1 ..... 100 A  
AC-3 ..... 75 A  
Breaking Capacity ..... 8 x 75 A  
Making Capacity ..... 10 x 75 A

Power (AC-3) ..... 25 hp

Option 1:

Voltage ..... 3 PH, 3 wire (no neutral),  
50/60 Hz<sup>(2)</sup>, 240 Vac  
(+10, -15%)

Current:

AC-1 ..... 100 A  
AC-3 ..... 75 A  
Breaking Capacity ..... 8 x 75 A  
Making Capacity ..... 10 x 75 A

Power (AC-3) ..... 30 hp

Option 2:

Voltage ..... 3 PH, 3 wire (no neutral),  
50/60 Hz<sup>(2)</sup>, 480 Vac  
(+10, -15%)

Current:

AC-1 ..... 100 A  
AC-3 ..... 66 A  
Breaking Capacity ..... 8 x 66 A  
Making Capacity ..... 10 x 66 A

Power (AC-3) ..... 60 hp

Option 3:

Voltage ..... 3 PH, 3 wire (no neutral),  
50/60 Hz<sup>(2)</sup>, 600 Vac  
(+10, -15%)

Current:

AC-1 ..... 100 A  
AC-3 ..... 55 A  
Breaking Capacity ..... 8 x 55 A  
Making Capacity ..... 10 x 55 A

Power (AC-3) ..... 75 hp

Trip Level Settings:

GFCI ..... Fixed 20 mA  
EGFPD ..... 6, 10, 20, 30, 40, 50, 60,  
70, 80, 90, and 100 mA

Trip Time ..... Defined by:

$$T = \left( \frac{20}{I} \right)^{1.43}$$

or minimum 20 ms. See Section 4.1.

Wiring and Torque Requirements:

Input Terminals:

Conductor Size ..... 14 to 2/0 AWG  
(2.08 to 67.4 mm<sup>2</sup>)

Torque:

14 to 2/0 AWG  
(2.08 to 67.4 mm<sup>2</sup>) ..... 275 lbf-in (31.1 N·m)

Output Terminals:

Conductor Size ..... 14 to 2/0 AWG  
(2.08 to 67.4 mm<sup>2</sup>)

Torque:

6 to 2/0 AWG  
(13.3 to 67.4 mm<sup>2</sup>) ..... 120 lbf-in (13.6 N·m)  
14 to 8 AWG  
(2.08 to 8.36 mm<sup>2</sup>) ..... 40 lbf-in (4.5 N·m)

Ground Terminals:

Conductor Size ..... 14 to 1/0 AWG  
(2.08 to 53.5 mm<sup>2</sup>)

Torque:

14 to 10 AWG  
(2.08 to 5.26 mm<sup>2</sup>)... 35 lbf-in (4.0 N·m)  
8 AWG  
(8.36 mm<sup>2</sup>) ..... 40 lbf-in (4.5 N·m)  
6 to 4 AWG  
(13.3 to 21.1 mm<sup>2</sup>)... 45 lbf-in (5.1 N·m)  
3 to 1/0 AWG  
(26.7 to 53.5 mm<sup>2</sup>)... 50 lbf-in (5.6 N·m)

Ground-Check and Auxiliary Terminals:

Conductor Size ..... 22 to 12 AWG  
(0.33 to 3.3 mm<sup>2</sup>)

PWB Conformal Coating ..... MIL-1-46058 qualified  
UL QMJU2 recognized

Ground-Check Circuit:

Open-Circuit Voltage ..... 12 Vdc  
Output Impedance ..... 200 Ω  
Nominal Loop Current ..... 30 mA  
Induced-ac Withstand ..... 25 Vac  
GC-Loop Trip Resistance ... 38 ± 2 Ω

Auxiliary Contact:

Contact Configuration ..... Normally Open (N.O.)  
UL Rating ..... 4 A Resistive,  
220/240 Vac;  
0.3 A Resistive, 250 Vdc

**Security:**

Open-Chassis.....Tamper-indicating labels installed  
Enclosure.....Lockable latch

**Short-Circuit Current**

Rating<sup>(3)</sup> .....50 kA

**Fuse Requirements:**

**F1:**

Fuse Rating.....0.25 A, 250 Vac, Time Delay, 3AG  
Fuse Part Number .....Littelfuse 0313.250HX or 0313.250HXP (RoHS)

**F2 and F3:**

**480 and 600 V Systems:**

Fuse Rating .....0.8 A, 600 Vac, Class CC  
Fuse Part Number .....Littelfuse KLDR.800T or KLDR.800TXP (RoHS)

**208 and 240 V Systems:**

Fuse Rating .....2 A, 600 Vac, Class CC  
Fuse Part Number .....Littelfuse KLDR002.T or KLDR002.TXP (RoHS)

**Input Fuses (3):**

Fuse Rating.....200 A, 600 Vac, Class T  
Fuse Part Number .....Littelfuse JLLS200.X  
Interrupting Rating .....200 kA

Enclosure.....NEMA 4X, Polyester, Lockable

**Dimensions:**

**SB6100-XX0-0 Open-Chassis Models:**

Height .....455.0 mm (17.9")  
Width .....340.7 mm (13.4")  
Depth .....174.9 mm (6.9")

**SB6100-XX1-0 Enclosed Models:**

Height .....453.8 mm (17.9")  
Width .....406.2 mm (16.0")  
Depth .....223.3 mm (8.8")

**Shipping Dimensions:**

**SB6100-XX0-0 Open-Chassis Models:**

Height .....508 mm (20.0")  
Width .....406 mm (16.0")  
Depth .....203 mm (8.0")

**SB6100-XX1-0 Enclosed Models:**

Height .....550 mm (21.6")  
Width .....490 mm (19.2")  
Depth .....240 mm (9.4")

**Shipping Weight:**

Open-Chassis Models ..... 9.5 kg (21 lb)  
Enclosed Models ..... 14.5 kg (32 lb)

**Environment:**

**Operating Temperature:**

UL Rating.....-35 to 40°C (-31 to 104°F)  
UL Test.....100 A, 40°C (104°F), 85% Supply Voltage

Supplemental Rating..... See Fig. 14

Storage Temperature .....-55 to 80°C (-67 to 176°F)

Humidity.....93% Non-Condensing

**Certification:**

All Models..... CSA



LR 53428

UL 1998<sup>(4)</sup>

**GFCI:**

**Enclosed:**

Class C ..... UL 943C listed



Ground-Fault Circuit Interrupter  
Class C  
E352763  
Issue No. B-513,119

Class D ..... UL 943C listed



Ground-Fault Circuit Interrupter  
Class D  
E352763  
Issue No. B-513,121

Open-chassis ..... UL 943C recognized component



Littelfuse Inc.  
SB6100

**EGFPD:**

Enclosed..... UL 943/UL 1053 listed



Equipment Ground-Fault Protective Device  
E355574  
Issue No. B-513,120

Open-chassis ..... UL 943/UL 1053 recognized component



Littelfuse Inc.  
SB6100

To: CSA C22.2 No. 144-M91 Ground Fault Circuit Interrupters, Class 1451-01 (GFCI) or 4812-02 (EGFPD)  
UL 943 Ground-Fault Circuit-Interrupters  
UL 943C Special Purpose Ground-Fault Circuit-Interrupters  
UL 1053 Ground Fault Sensing and Relaying Equipment  
UL 1998 Software in Programmable Components

**NOTES:**

<sup>(1)</sup> IEC 60947-1 Annex A defines several utilization categories. AC-1 refers to non-inductive or slightly inductive loads. AC-3 refers to squirrel-cage motors.



- (2) UL 943C does not apply to 50-Hz installations.
- (3) Performed at Littelfuse Test Lab.
- (4) Hardware revision 01 or newer.

**7.2 AC6000-CART**

Maximum Holding Weight<sup>(1)</sup>.....45 kg (100 lb)

Dimensions<sup>(2)</sup>:

Height.....1,064 mm (42.0")  
Width.....648 mm (25.5")  
Depth.....662 mm (26.0")

Shipping Dimensions<sup>(2)</sup>:

Height.....1,016 mm (40.0")  
Width.....457 mm (18.0")  
Depth.....203 mm (8.0")

Weight.....9 kg (22 lb)

Shipping Weight .....11 kg (25 lb)

Material/Finish.....Aluminum / Powder  
Coat Gloss Black

Wheels.....Solid Polypropylene  
(Maintenance Free)

**NOTES:**

- (1) Including SB6100 and any cable and accessories.
- (2) Includes the AC6000-MNT-00.

**7.3 AC6000-MNT**

Maximum Holding Weight<sup>(1)</sup>.....40 kg (90 lb)

Dimensions:

Height.....705 mm (28.0")  
Width.....648 mm (25.5")  
Depth.....152 mm (6.0")

Shipping Dimensions

Height.....152 mm (6.0")  
Width.....152 mm (6.0")  
Depth.....762 mm (30.0")

Weight.....1 kg (2 lb)

Shipping Weight .....2 kg (4 lb)

Material/Finish.....Aluminum / Powder  
Coat Gloss Black

**NOTES:**

- (1) Including SB6100 and any cable and accessories.

**8. ORDERING INFORMATION**

SB6100- 

--	--	--

 -0

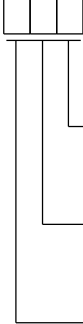

**Mechanical:**

- 0 Open-Chassis Models
- 1 Enclosed Models

**Device Type:**

- 0 GFCI
- 1 EGFPD

**Voltage Rating:**

- 0 208 V
- 1 240 V
- 2 480 V
- 3 600 V

Termination Assemblies<sup>(1)</sup>:

- 1N5339B..... 5-W Axial Lead Termination Device
- SE-TA6..... 50-W Termination Assembly
- SE-TA6-SM..... 50-W Stud-Mount Termination Assembly
- SE-TA6ASF-WL..... 12-W Small Format Termination Assembly with Wire Leads

Accessories:

- AC6000-OPI-00..... Operator Interface
- AC6000-CART-00..... Two-wheeled Cart<sup>(2)</sup> <sup>(3)</sup>
- AC6000-MNT-00..... Mounting Frame<sup>(3)</sup>

**NOTES:**

- (1) All SB6100 models include a 1N5339B Termination Device.
- (2) Includes the AC6000-MNT-00.
- (3) Item is shipped unassembled.

### APPENDIX A SB6100 REVISION HISTORY

MANUAL RELEASE DATE	MANUAL REVISION	PRODUCT REVISION (REVISION NUMBER ON PRODUCT LABEL)
March 26, 2018	1-H-032618	01
April 24, 2017	1-G-042417	
April 1, 2016	1-F-040116	
January 5, 2016	1-E-010516	
July 10, 2015	1-D-071015	
November 6, 2014	1-C-110614	00
November 29, 2013	1-B-112913	
May 8, 2013	1-A-050813	
February 1, 2013	0	

#### MANUAL REVISION HISTORY

##### REVISION 1-H-032618

###### SECTION 2

Section 2.2.1 removed.

Fig. 3 removed, all other Figures renumbered.

###### GENERAL

SB6100 enclosure has been changed to grey.

##### REVISION 1-G-042417

###### SECTION 3

Section 3.10 updated.

##### REVISION 1-F-040116

###### SECTION 3

Input terminals note added.

###### SECTION 4

Section 4.1 updated.

Fig. 16 added.

###### SECTION 7

Voltage, current, and power ratings updated.

##### REVISION 1-E-010516

CSA certification included for all revisions.

###### SECTION 2

Figs. 2, 3, 4, 5, and 8 updated.

###### SECTION 3

Fig. 13 updated.

Fig. 15 added.

###### SECTION 7

Trip time formula added.

##### REVISION 1-D-071015

###### SECTION 1

EGFPD model trip selector switch updated.

###### SECTION 2

Figs. 4, 5, 6, 10, and 11 updated.

###### SECTION 3

TEST/STOP and RESET/START buttons updated.

Section 3.10 added.

###### SECTION 5

Self Test Failure added.

**SECTION 7**

UL 1998 certification added.

**REVISION 1-C-110614**

**SECTION 6**

Figs. 14 and 15 updated.

**SECTION 7**

CSA certification added

**REVISION 1-B-112913**

**SECTION 2**

AC6000-CART-00 and AC6000-MNT-00 figures added.

**SECTION 7**

AC6000-CART-00 (Section 7.2) and AC6000-MNT-00 (Section 7.3) specifications added.

**SECTION 8**

AC6000-CART-00, AC6000-OPI-00, and AC6000-MNT-00 added.

**REVISION 1-A-050813**

**APPENDIX A**

Revision history added.

**REVISION 0**

Initial release.

**PRODUCT REVISION HISTORY**

**PRODUCT REVISION 01**

Includes self-test function and UL 1998 compliance.  
Extends trip levels up to 100 mA for EGFPD models.

**PRODUCT REVISION 00**

Initial release.

This page intentionally left blank.