

PART NO.	ENG. NO.
02-09-1205	4550-A(P901)
02-09-1206	4550-A(P901)L
02-09-5169	4550-A(P558)
02-09-5170	4550-A(P558)L

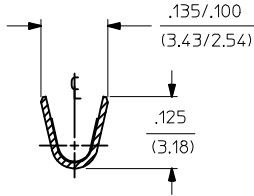
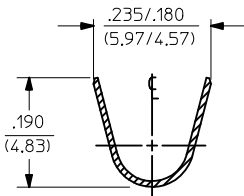
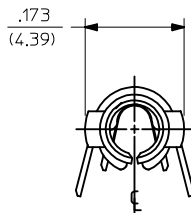

SECTION "A-A"

SECTION "B-B"

LEGEND
 4550-A(****)*
 P=PREPLATE
 BLANK=POSTPLATE
 FORM
 BLANK=CHAIN
 L=LOOSE
 FINISH CODE

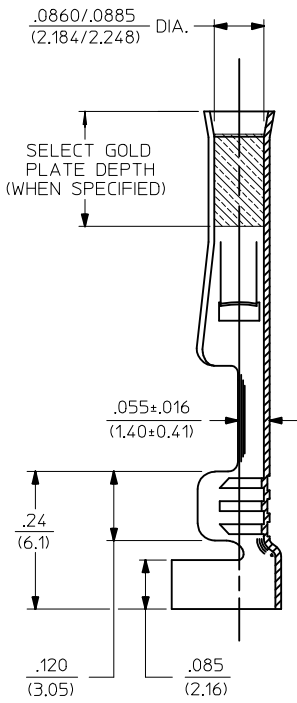
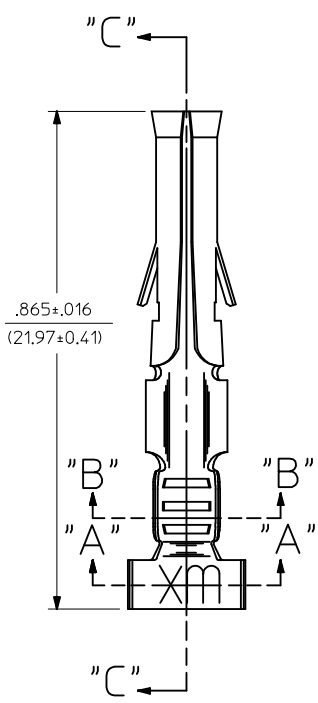

SECTION "C-C"

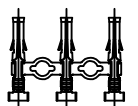
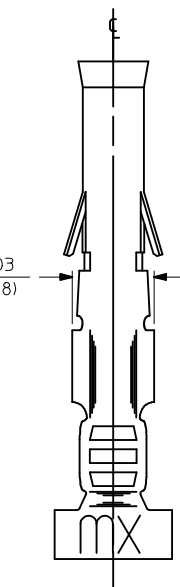

CHAIN FORM FULL SCALE

NOTES:

1. MATERIAL: PHOSPHOR BRONZE
2. FINISHES:
 901 - HOT TIN DIP .000020/(0.00051) MIN.
 558 - SELECT GOLD PLATE .000030/(0.00076) MIN. IN CONTACT AREA, OVER .000050/(0.00127) MIN. NICKEL OVERALL WITH .000010/(0.00025) MAX. GOLD FLASH.
3. THIS PART CONFORMS TO PROD. SPEC. 02-09.
4. TERMINAL FOR USE WITH .093/(2.36) SERIES HOUSINGS AND WILL ACCEPT 14 THRU 20 AWG WIRE.
5. INSERTION FORCE: 3.5 LBS. MAX. WHEN TERMINAL IS INSERTED INTO AN .093 SERIES HOUSING.
6. RETENTION: 20 LBS. MIN. FROM HOUSING.

REMOVE DIMPLE EC NO: UCP2015-0104 DRWN:JDFX 2014/07/29 CHKD:HK/PPER 2014/07/29 APPR:FSM/LTH 2014/07/31	QUALITY SYMBOLS	GENERAL TOLERANCES (UNLESS SPECIFIED)		DIMENSION STYLE	SCALE	DESIGN UNITS	THIRD ANGLE PROJECTION	
	▽=0	mm	INCH	IN/MM	6:1	INCH		
	▽=0	4 PLACES ± ---	± ---	DRAWN BY	DATE	TITLE		
	▽=0	3 PLACES ± ---	± .010	GWC	1991/05/02	CRIMP TERMINAL, FEMALE		
		2 PLACES ± 0.25	± .014	CHECKED BY	DATE			
		1 PLACE ± 0.35	± ---	RW	1991/05/02			
		0 PLACE ±	±	APPROVED BY	DATE			
				GW	1991/05/02			
		ANGULAR ±1/2°		MATERIAL NO.	DOCUMENT NO.			
		DRAFT WHERE APPLICABLE MUST REMAIN WITHIN DIMENSIONS		SEE CHART	SD-4550-*	SHEET NO. 1 OF 1		
		THIS DRAWING CONTAINS INFORMATION THAT IS PROPRIETARY TO MOLEX INCORPORATED AND SHOULD NOT BE USED WITHOUT WRITTEN PERMISSION						