

SD-6482-1\*

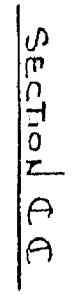
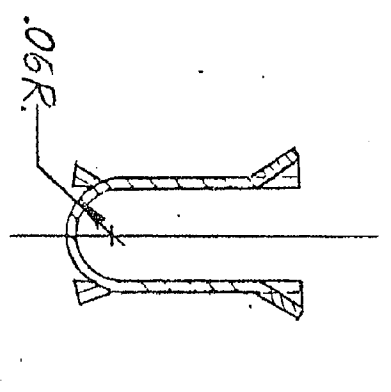
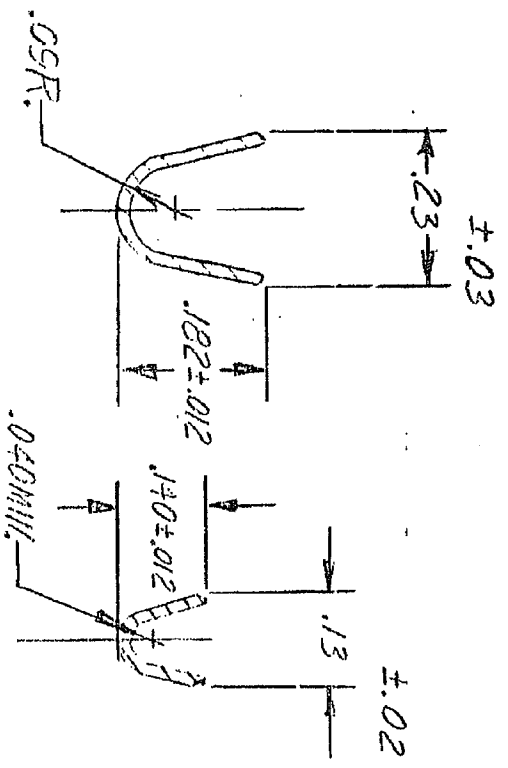
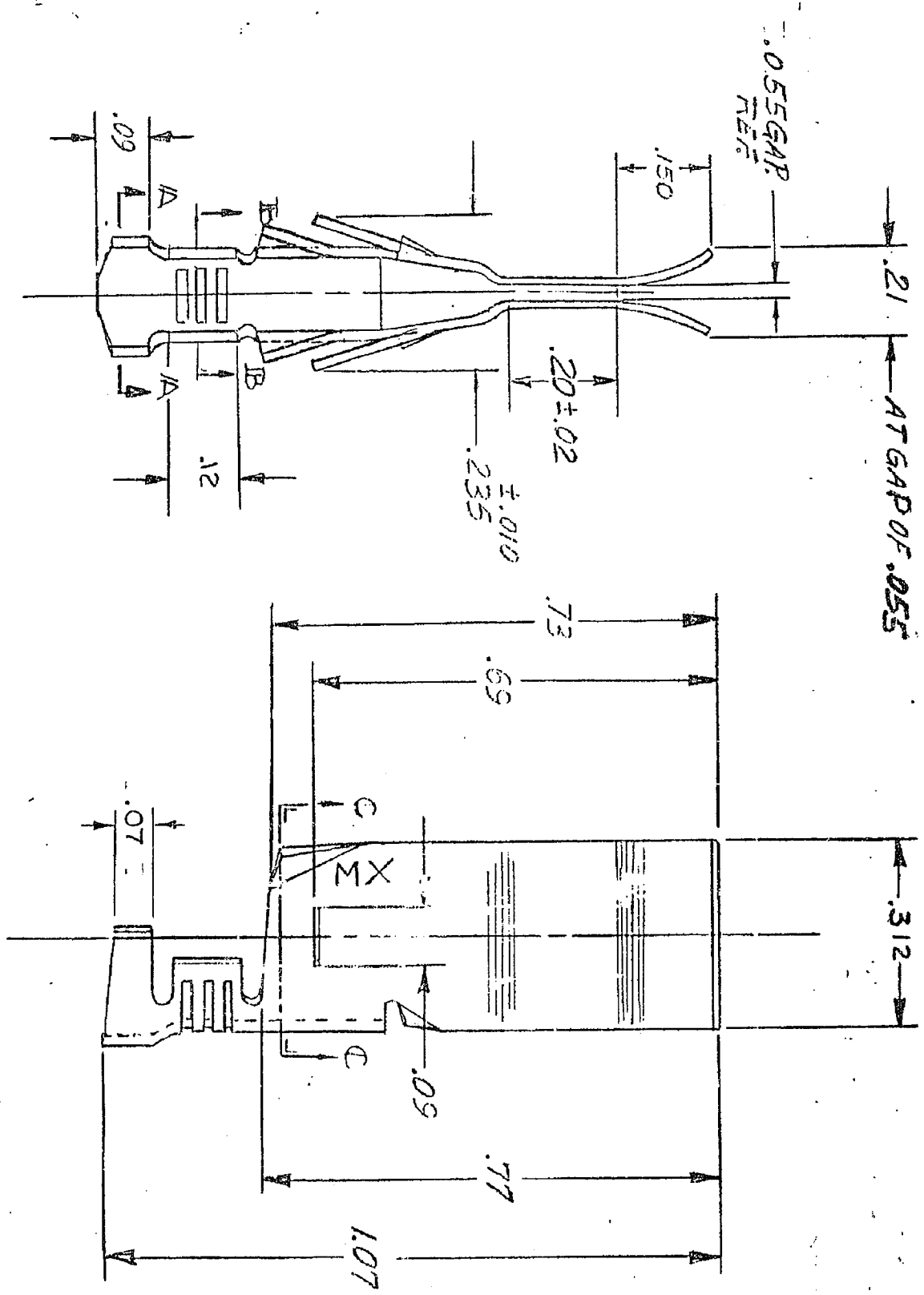

NOTES:  
 ▲ FOR CRIMPING 14 TO 18 A.W.G. WIRE.

PART No	ENG No	DESCRIPTION
05-12-1102	6482-1	CHAIN

MATERIAL:  
 BRONZE, HIGH TEMPERATURE, .016 THICK.

D	DELETE PART NO. ECR U2-1706 23-01-20 AG
C	.07 ADDED. ECR U8-2273 11-29-88 MB
B	REVISE MAT'L. CALL OUT BRONZE WAS BRASS # ADD EDP NO. TO 6482-1L ERO # 22731 6-12-86 JCS MB
A	ADD EDP # TO 6482-1 PER ERO # 19397 10-5-84 JCS
1	X-RELEASE PER ERO # 14276 10-12-81 JOK

REVISIONS

UNLESS OTHERWISE SPECIFIED  
 TOLERANCES:  
 3-PLACE DEC. DIMS ±.010  
 2-PLACE DEC. DIMS ±.014  
 ANGULAR ± 1/2°  
 DRAFT WHEN APPLICABLE MUST REMAIN WITHIN DIRECTIONS, UNLESS OTHERWISE SPECIFIED.  
 DO NOT SCALE DRAWING

TERMINAL  
 MOLEX PRODUCTS CO.  
 DOWNERS GROVE, ILL. 60515, U.S.A.  
 DATE 10-12-81  
 SD-6482-1\*