

ASSEMBLY SERIES

70400
70430
70431
70456
70475

NOTES:

1. STAPLES MAY BE USED TO SET UP STANDARD CARTON ONLY. CARTON CLOSURES MUST BE DONE WITH TAPE.
2. 2 CIRCUIT ASSEMBLIES ARE CHAINED TOGETHER WITH 2 ASSEMBLIES PER CHAIN.
3. TUBE LABEL TO HAVE PART NUMBER, TRACKING NUMBER AND BOX NUMBER. TUBE LABEL TO BE PLACED APPROXIMATELY AS SHOWN. ONLY ONE TUBE LABEL PER MAGAZINE STACK.

CIRCUIT SIZE	PARTS PER TUBE	PARTS PER CARTON SPQ
2 SEE NOTE 2	104	3120
3	70	2100
4	53	1590
5	42	1260
6	35	1050
7	30	900
8	26	780
9	23	690
10	21	630
11	19	570
12	17	510
13	16	480
14	15	450
15	14	420
16	13	390
17	12	360
18	11	330
19	11	330
20	10	300
21	10	300
22	9	270
23	9	270
24	8	240
25	8	240

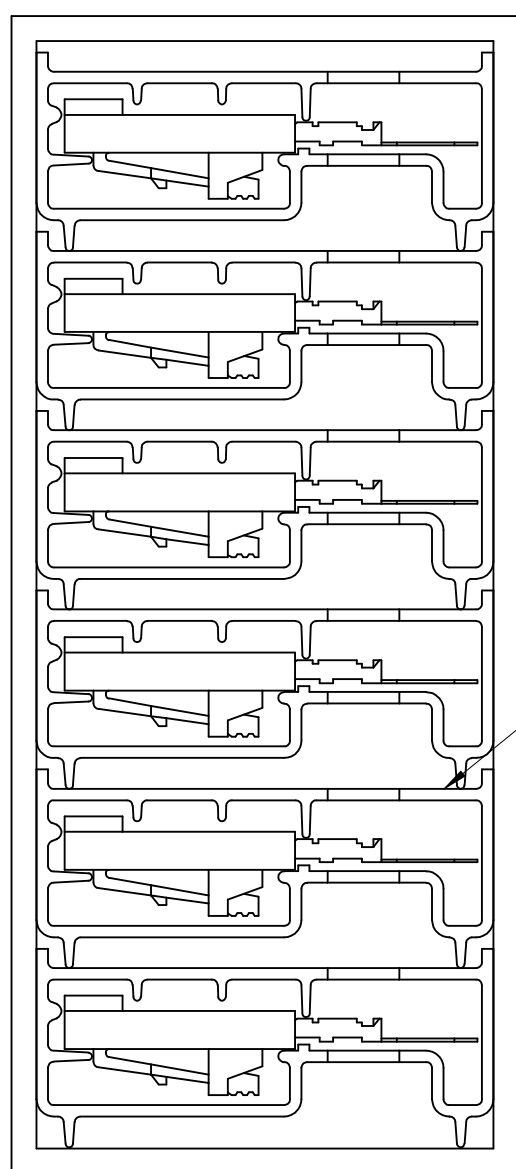
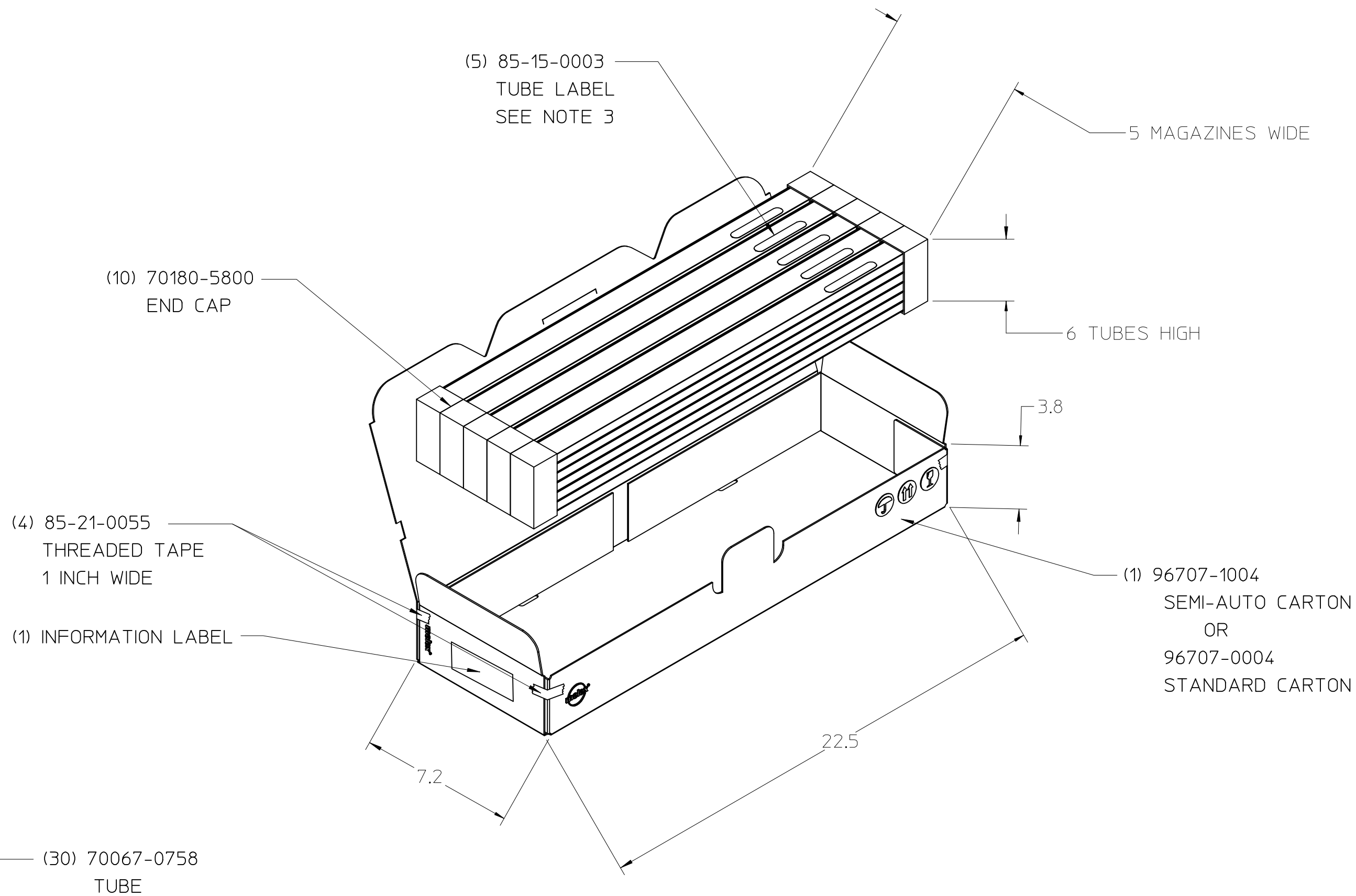

ADD SERIES 70456 EC NO: UCP2013-1408 DRWN: TIBARRA 2012/10/10 CHKD: APPR: SMILLER 2012/10/25	QUALITY SYMBOLS ▽=0 ▽=0 ▽=0	GENERAL TOLERANCES (UNLESS SPECIFIED)		DIMENSION STYLE MM ONLY		SCALE 1:4	DESIGN UNITS INCH	THIRD ANGLE PROJECTION	
		4 PLACES ± ---	± ---	mm	INCH	DRAWN BY TO		DATE 1985/12/20	
D2	REV	3 PLACES ± ---	± ---	CHECKED BY TO		DATE 1985/12/20		TITLE CUSTOMER PACKAGING FOR SERIES 70400, 70430, 70431, & 70475	
		2 PLACES ± ---	± ---	APPROVED BY TO		DATE 1985/12/20			
DRAFT WHERE APPLICABLE MUST REMAIN WITHIN DIMENSIONS		1 PLACE ± ---	± ---	MATERIAL NO. 085-22-0007		DOCUMENT NO. PK-70873-0001		SHEET NO. 1 OF 1	
		0 PLACE ±	±	THIS DRAWING CONTAINS INFORMATION THAT IS PROPRIETARY TO MOLEX INCORPORATED AND SHOULD NOT BE USED WITHOUT WRITTEN PERMISSION					