



Datasheet
Crimp Terminals

[Crimp](#)

[[Home](#) > [Products](#) > [Terminals](#) > [Datasheet](#)]

02-06-1132

1.57mm (.062") Diameter, Standard .062" Pin and Socket Crimp Terminal, Series 1855, Female, with Tin (Sn) Plated Brass Contact, 24-30 AWG, Bag

[View all parts in series 1855](#)
[2D Dimensions](#)
[Final this page](#)
[Samples](#)
[Buy](#)

Status	Active
Access Level	Internet
Product Name	Standard .062"
Molex Series	1855
Gender	Female
Wire Size [AWG]	24, 26, 28, 30
Wire Insulation Diameter	1.02-2.29mm (.040-.090")
Packaging	Bag
PHYSICAL	
Contact	Brass (CuZn)
Plated	Pre
Plating Contact	Tin (Sn)
Plating in Crimp Area	Tin (Sn)
Under Plating	Nickel (Ni)
Plating Thickness	0.5µm (20µ")
REFERENCE	
Termination	Good Crimps
990 Catalog Page	K-60
MX01 Catalog Page	F-136
Old Part Number	1855-(P901)L
Product Management	Farnsworth, Gregg
Lab Office	UCP
Customer Approved	Delco, Motorola

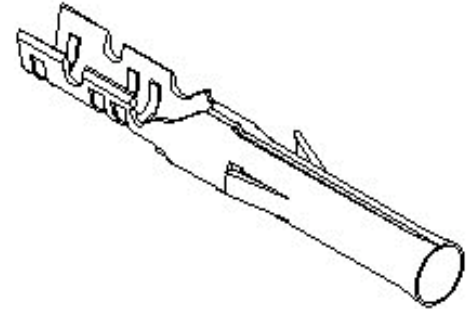

This part is **ELV** and **RoHS COMPLIANT**

ENVIRONMENT	
RoHS Compliant	Yes
Lead-free Process Capability Tested	No

Related Products

APPLICATION TOOLING		
Region	Description	Product Number
Americas	Hand Crimper	11-01-0185
Americas	Manual Extraction Tool	11-03-0002
Americas	Hand Crimper - DISTRIBUTION ONLY	63811-1000
Asia	Hand Insertion Tool	11-02-0001
Europe	Parallel Action Handtool for 1854, 1855 Terminals, 22-28 AWG	69008-0958

2D D R A W I N G - For reference only. See technical [Drawing \(PDF\)](#) for design-in purposes.

Contact
Material
Thickness
0.20mm
(.008")

