

NOTES: VALID UNLESS OTHERWISE SPECIFIED

1. GENERAL:

- a. APPLICATION SPECIFICATION: AS-31386-200
- b. PRODUCT SPECIFICATION: PS-31387-200
- c. PACKAGING SPECIFICATION: PK-31301-916
- d. PARTS MUST BE IN COMPLIANCE TO MOLEX CHEMICAL SUBSTANCES FOR PRODUCTS AND PACKAGING SPECIFICATION: ES-40000-5016
- e. DATA MUST BE SUBMITTED UNDER THE MOLEX PART NUMBER TO IMDS (COMPANY ID#13255)
- f. DIMENSIONS AND TOLERANCES ARE VALID FOR AS SHIPPED SHROUD ASSEMBLY
- g. REFERENCE GM INTERFACE CONTROL DRAWINGS (ICD)
 - 1. 12582682 (Au)
 - 2. 12642695 (Ag)

2. DESIGN - MATERIALS:

- a. PLASTIC: PBT 30% GF - SEE CHART FOR COLOR
- b. SIGNAL PIN PLATING:
 - UNDERPLATE: NICKEL 1.27-2.54 μ m
 - SELECT GOLD OPTION: 0.76 μ m MIN.
 - SELECT SILVER OPTION: 1.90-3.30 μ m MIN
 - SOLDER TAIL SELECT TIN: 5.08-10.16 μ m BRIGHT FINISH

3. DESIGN - GEOMETRY:

- a. THIS IS A 100% CAD GENERATED PART. THE CAD MATHEMATICAL DATA IS THE MASTER FOR ALL NON-DIMENSIONAL FEATURES. DRAWING DIMENSIONS SHALL BE MET WHEN DIFFERENCES EXIST BETWEEN THE DRAWING AND THE CAD MODEL. UNDERLINED DIMENSIONS OR DIMENSIONS INDICATED AS "EDITED" MAY BE DIFFERENT FROM THE 3D MODEL GEOMETRY. FOR DIMENSIONAL OR ANY INFORMATION NOT SHOWN ON THIS DRAWING, ANALYZE THE CAD MODEL.
- b. PRODUCT DESIGN MODEL NUMBER(S): SEE BOM TABLE
- c. GEOMETRIC DIMENSIONS AND TOLERANCES PER ASME Y14.5M-1994
- d. GENERAL TOLERANCES - SEE TABLE

4. DESIGN - MANUFACTURING:

- a. HUMAN READABLE LASER MARKING
 - 1. INFORMATION TO BE PRINTED:
 - DDDY - 4 DIGIT JULIAN DATE CODE
 - S_HH - STITCHER NUMBER_HOUR NUMBER (24 HOUR CLOCK)
 - MMMM - LAST FOUR DIGITS OF MOLEX MATERIAL NUMBER
 - 2. SIZE: HUMAN LEGIBLE
- b. PIN MATE SIDE AND PCB SIDE TRUE POSITION TO BE VERIFIED ONLINE WITH A GO/NO-GO FUNCTIONAL GAGE.
- c. ANTI-TARNISH FOR Ag PLATING ONLY: SYTHETIC HYDROCARBON CONTACT SURFACE FINISH OR EQUIVALENT APPLIED WITHOUT VOID TO CONTACT AREA (MIN. 3.7mm FROM PIN TIP).
- d. VISUAL DEFECTS SHALL MEET COSMETIC STANDARD PS-45499-002 (CLASS B). WITHIN THE SEALING SURFACE/ZONE SUCH AS PARTING LINES, MISMATCHES, SINK, TEXTURE VARIATIONS, SCRATCHES/GOUGES, SHORT FILL, PROTRUSIONS, PITS, DENTS/NICKS, BLISTERS OR EJECTOR MARKS.

INSPECTION BALLOON NUMBER LOG	
PER DRAWING REVISION: B6	
LAST BALLOON NUMBER: 47	
ADDED BALLOON NUMBER: 1 2 8 10 11 19 20 24 25 26 27 28 29 30 31 32 33 34 35	
36 37 38 39 40 41 42 43 44 46 47	
DELETED INSPECTION BALLOON NUMBER: 3 4 5 6 7 9 12 13 14 15 16 17 18 21 22 23 45	

REV	DESCRIPTION
B11	UPATED PCN 505530 FOR MINOR DRAFT AND RADII
B10	NX REMASTERING
B9	CORRECTED KEY H 'DIM B' VALUE
B8	CORRECTED KEY H 'DIM A' VALUE; CHANGE STATUS TO SALEABLE
B7	UPDATED NOTE 1c SAP# 10595870
B6	ADDED NOTE 4d, e & SEALING ZONE ON PG 2 SAP# 10586362
B5	ADDED BALLOON NUMBERS 1,2,10,11,19,20, 24-44,46,47; DELETED BALLOON NUMBERS 3-7,9,12-15,17, 18, 21-23, 45 EDITED ALL NOTES, STATUS & MATING HARNESS PART NUMBER SAP# 10580347

THIS DRAWING CONTAINS INFORMATION THAT IS PROPRIETARY TO MOLEX ELECTRONIC TECHNOLOGIES, LLC AND SHOULD NOT BE USED WITHOUT WRITTEN PERMISSION																																																														
<table border="1"> <tr> <th>QUALITY SYMBOLS</th> <th>DESCRIPTION</th> </tr> <tr> <td></td> <td>= 0</td> </tr> <tr> <td></td> <td>= 0</td> </tr> <tr> <td></td> <td>= 0</td> </tr> <tr> <td></td> <td>= 0</td> </tr> <tr> <td></td> <td>= 0</td> </tr> <tr> <td></td> <td>= 0</td> </tr> <tr> <td></td> <td>= 0</td> </tr> <tr> <td></td> <td>= 0</td> </tr> <tr> <td></td> <td>= 0</td> </tr> </table>	QUALITY SYMBOLS	DESCRIPTION		= 0		= 0		= 0		= 0		= 0		= 0		= 0		= 0		= 0	<table border="1"> <tr> <td>EC NO: 606583</td> <td>2018/10/15</td> <td>2018/12/10</td> <td>2018/12/10</td> </tr> <tr> <td>DRWN: BSKANTHARAJU</td> <td></td> <td></td> <td></td> </tr> <tr> <td>CHKD: DKRAWCZYK</td> <td></td> <td></td> <td></td> </tr> <tr> <td>REV APPR: DKRAWCZYK</td> <td></td> <td></td> <td></td> </tr> </table>	EC NO: 606583	2018/10/15	2018/12/10	2018/12/10	DRWN: BSKANTHARAJU				CHKD: DKRAWCZYK				REV APPR: DKRAWCZYK																												
QUALITY SYMBOLS	DESCRIPTION																																																													
	= 0																																																													
	= 0																																																													
	= 0																																																													
	= 0																																																													
	= 0																																																													
	= 0																																																													
	= 0																																																													
	= 0																																																													
	= 0																																																													
EC NO: 606583	2018/10/15	2018/12/10	2018/12/10																																																											
DRWN: BSKANTHARAJU																																																														
CHKD: DKRAWCZYK																																																														
REV APPR: DKRAWCZYK																																																														
<table border="1"> <tr> <th colspan="2">GENERAL TOLERANCES (UNLESS SPECIFIED)</th> <th>DIMENSION UNITS</th> <th>SCALE</th> </tr> <tr> <td colspan="2">ANGULAR TOL \pm 3.0 °</td> <td>MM</td> <td>2:1</td> </tr> <tr> <td>4 PLACES \pm</td> <td></td> <td>DRWN BY</td> <td>DATE</td> </tr> <tr> <td>3 PLACES \pm</td> <td></td> <td>FJAKLIC</td> <td>04/30/08</td> </tr> <tr> <td>2 PLACES \pm 0.13</td> <td></td> <td>CHKD BY</td> <td>DATE</td> </tr> <tr> <td>1 PLACE \pm 0.25</td> <td></td> <td>FJAKLIC</td> <td>04/30/08</td> </tr> <tr> <td>0 PLACES \pm</td> <td></td> <td>APPR BY</td> <td>DATE</td> </tr> <tr> <td></td> <td></td> <td>GPRATT</td> <td>05/05/08</td> </tr> <tr> <td colspan="2">DRAFT WHERE APPLICABLE MUST REMAIN WITHIN DIMENSIONS</td> <td>DRAWING SIZE</td> <td>THIRD ANGLE PROJECTION</td> </tr> <tr> <td colspan="2"></td> <td>D</td> <td></td> </tr> </table>	GENERAL TOLERANCES (UNLESS SPECIFIED)		DIMENSION UNITS	SCALE	ANGULAR TOL \pm 3.0 °		MM	2:1	4 PLACES \pm		DRWN BY	DATE	3 PLACES \pm		FJAKLIC	04/30/08	2 PLACES \pm 0.13		CHKD BY	DATE	1 PLACE \pm 0.25		FJAKLIC	04/30/08	0 PLACES \pm		APPR BY	DATE			GPRATT	05/05/08	DRAFT WHERE APPLICABLE MUST REMAIN WITHIN DIMENSIONS		DRAWING SIZE	THIRD ANGLE PROJECTION			D		<table border="1"> <tr> <td colspan="3" style="text-align: center;">molex[®]</td> </tr> <tr> <td colspan="3" style="text-align: center;">80 CKT SHROUD ASSEMBLY 0.64 SQ. PINS MX123</td> </tr> <tr> <td colspan="3" style="text-align: center;">PRODUCT CUSTOMER DRAWING</td> </tr> <tr> <td>SERIES</td> <td>MATERIAL NUMBER</td> <td>CUSTOMER</td> </tr> <tr> <td>31387</td> <td>SEE CHART</td> <td>GENERAL MARKET</td> </tr> <tr> <td>DOCUMENT NUMBER</td> <td>DOC TYPE</td> <td>DOC PART SHEET NUMBER</td> </tr> <tr> <td>SD-31387-080</td> <td>PSD</td> <td>000 1 OF 3</td> </tr> </table>	molex [®]			80 CKT SHROUD ASSEMBLY 0.64 SQ. PINS MX123			PRODUCT CUSTOMER DRAWING			SERIES	MATERIAL NUMBER	CUSTOMER	31387	SEE CHART	GENERAL MARKET	DOCUMENT NUMBER	DOC TYPE	DOC PART SHEET NUMBER	SD-31387-080	PSD	000 1 OF 3
GENERAL TOLERANCES (UNLESS SPECIFIED)		DIMENSION UNITS	SCALE																																																											
ANGULAR TOL \pm 3.0 °		MM	2:1																																																											
4 PLACES \pm		DRWN BY	DATE																																																											
3 PLACES \pm		FJAKLIC	04/30/08																																																											
2 PLACES \pm 0.13		CHKD BY	DATE																																																											
1 PLACE \pm 0.25		FJAKLIC	04/30/08																																																											
0 PLACES \pm		APPR BY	DATE																																																											
		GPRATT	05/05/08																																																											
DRAFT WHERE APPLICABLE MUST REMAIN WITHIN DIMENSIONS		DRAWING SIZE	THIRD ANGLE PROJECTION																																																											
		D																																																												
molex [®]																																																														
80 CKT SHROUD ASSEMBLY 0.64 SQ. PINS MX123																																																														
PRODUCT CUSTOMER DRAWING																																																														
SERIES	MATERIAL NUMBER	CUSTOMER																																																												
31387	SEE CHART	GENERAL MARKET																																																												
DOCUMENT NUMBER	DOC TYPE	DOC PART SHEET NUMBER																																																												
SD-31387-080	PSD	000 1 OF 3																																																												

SHROUD ASSEMBLY NUMBER	MATE SIDE PIN FINISH	COLOR	HARNESS SIDE KEY CODE	PCB SIDE KEY LOCATION		MATING HARNESS PART NUMBER	STATUS
				DIM. "A" ±0.30	DIM. "B" ±0.30		
31387-4001	GOLD	BLUE	G	13.97	34.29	345660703 345661903	SALEABLE
31387-4009	GOLD	GRAY	H	19.05	34.29	345660803 345662003	SALEABLE
31387-4017	SILVER	BLUE	G	13.97	34.29	345660703 345661903	SALEABLE
31387-4018	SILVER	GRAY	H	19.05	34.29	345660803 345662003	SALEABLE

SHROUD ASSEMBLY TRACEABILITY INFORMATION FOR MOLEX INTERNAL USE ONLY (SEE NOTE 4a)

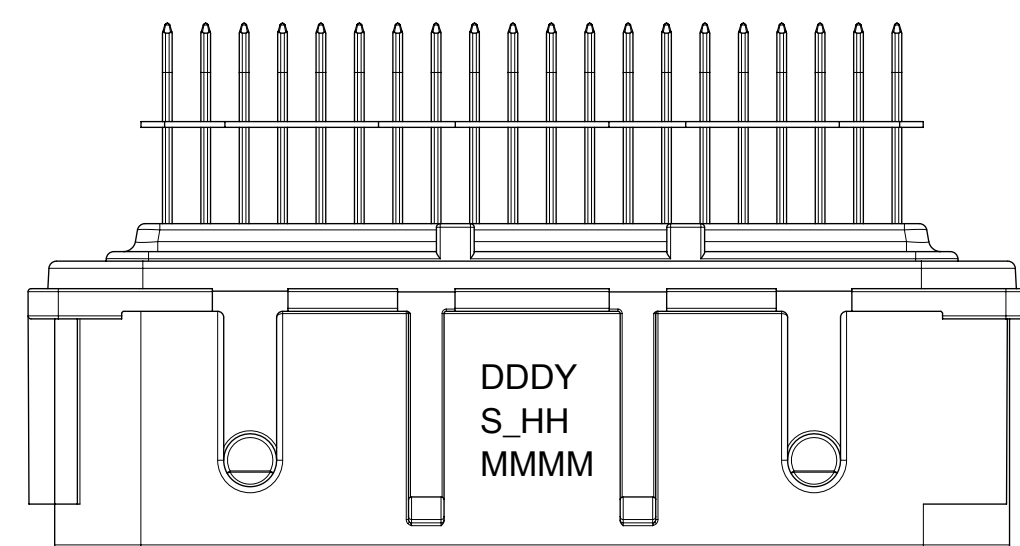
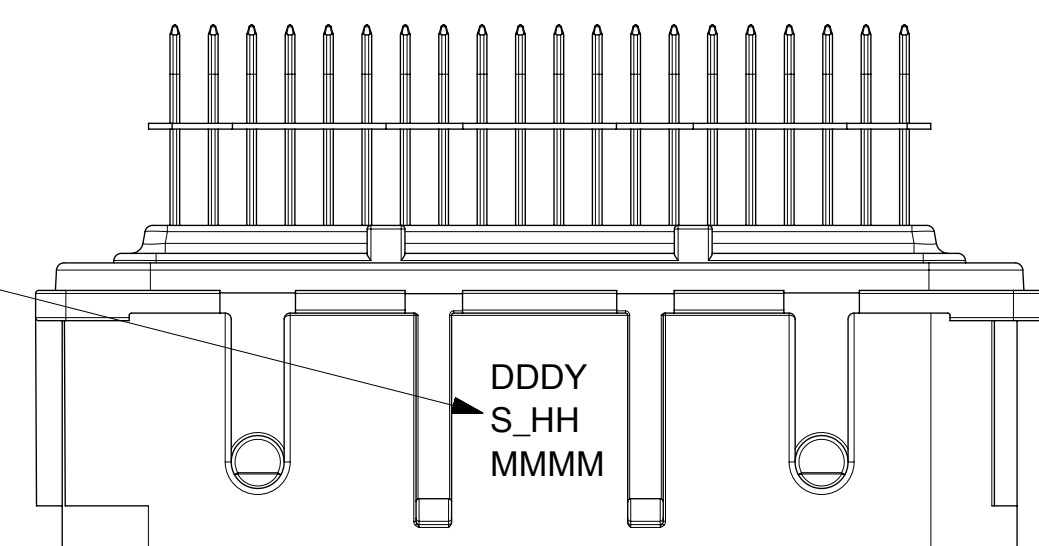

MATE SIDE POLARIZATION KEY AT CORNERS

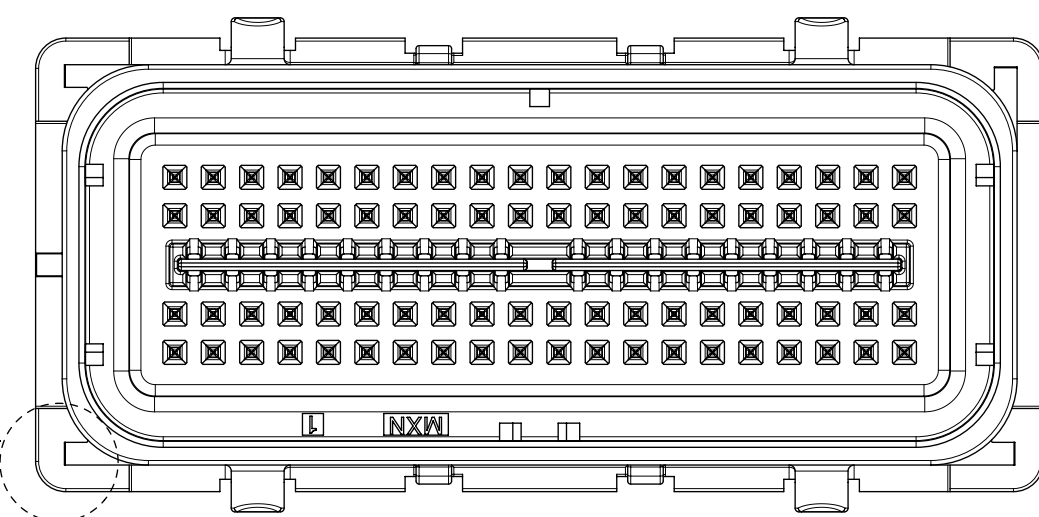

KEY OPTION "G"

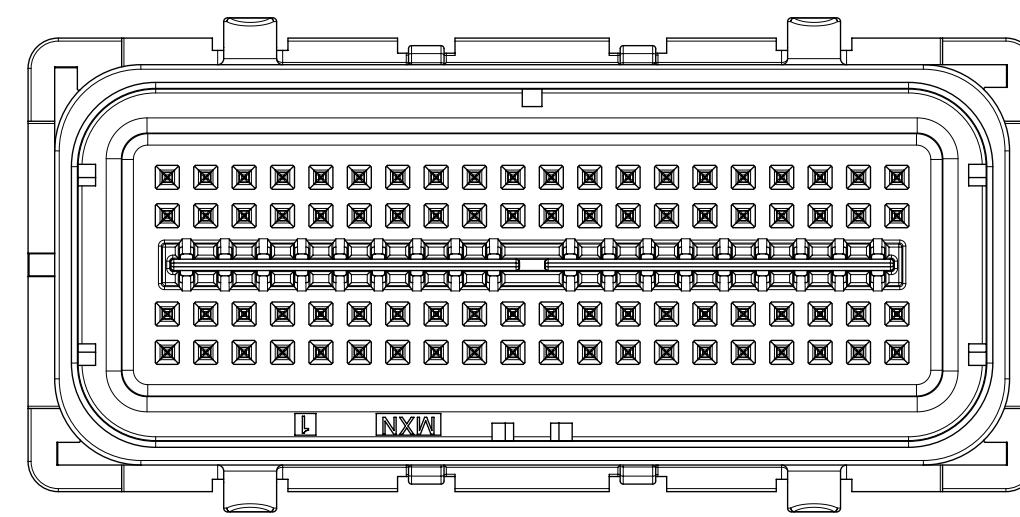

KEY OPTION "H"

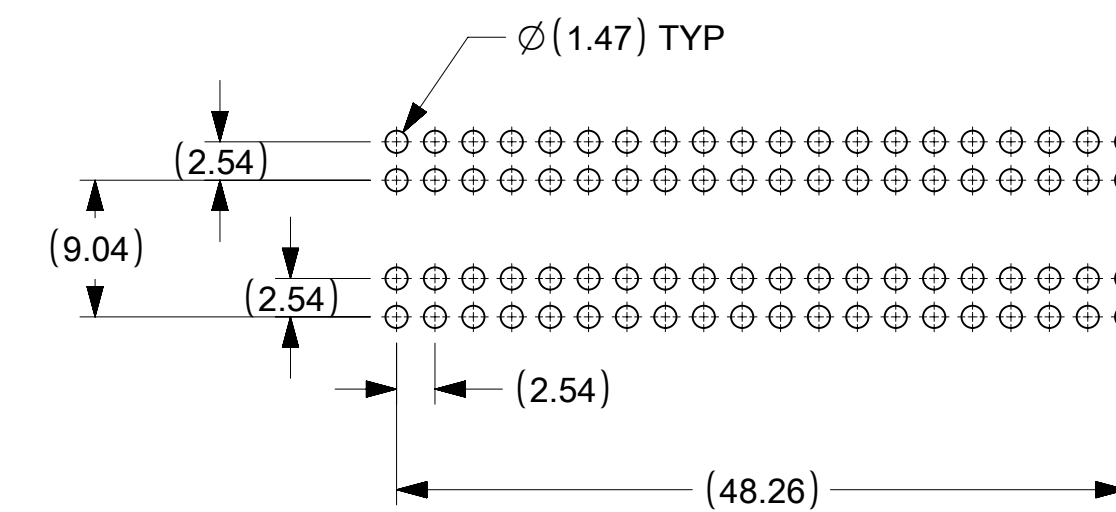

PCB LAYOUT FOR REFERENCE ONLY

QUALITY SYMBOLS 	THIS DRAWING CONTAINS INFORMATION THAT IS PROPRIETARY TO MOLEX ELECTRONIC TECHNOLOGIES, LLC AND SHOULD NOT BE USED WITHOUT WRITTEN PERMISSION										
	EC NO: 606583	DRWN: BSKANTHARAJU	CHKD: DKRAWCZYK	REV: APPR: DKRAWCZYK	2018/10/15	2018/12/10	2018/12/10	GENERAL TOLERANCES (UNLESS SPECIFIED)	DIMENSION UNITS	SCALE	
	ANGULAR TOL ± 3.0 °							MM	2:1	80 CKT SHROUD ASSEMBLY 0.64 SQ. PINS MX123	
	4 PLACES ±	FJKLIC		DATE		04/30/08		DRWN BY	DATE		
	3 PLACES ±	FJKLIC		DATE		04/30/08		CHKD BY	DATE	PRODUCT CUSTOMER DRAWING	
	2 PLACES ± 0.13	GPRATT		DATE		05/05/08		APPR BY	DATE		
	1 PLACE ± 0.25	D		THIRD ANGLE PROJECTION		D		DRAWING SIZE	THIRD ANGLE PROJECTION	SERIES: 31387 MATERIAL NUMBER: SEE CHART CUSTOMER: GENERAL MARKET	
	0 PLACES ±	DRAFT WHERE APPLICABLE MUST REMAIN WITHIN DIMENSIONS		D		D		D	THIRD ANGLE PROJECTION		
	0	B11		SD-31387-080		PSD		000		3 OF 3	

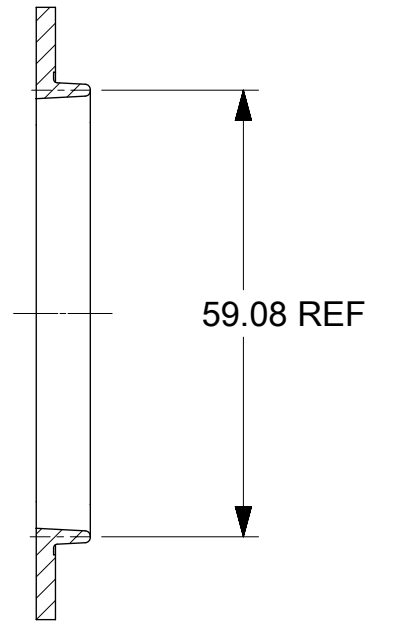
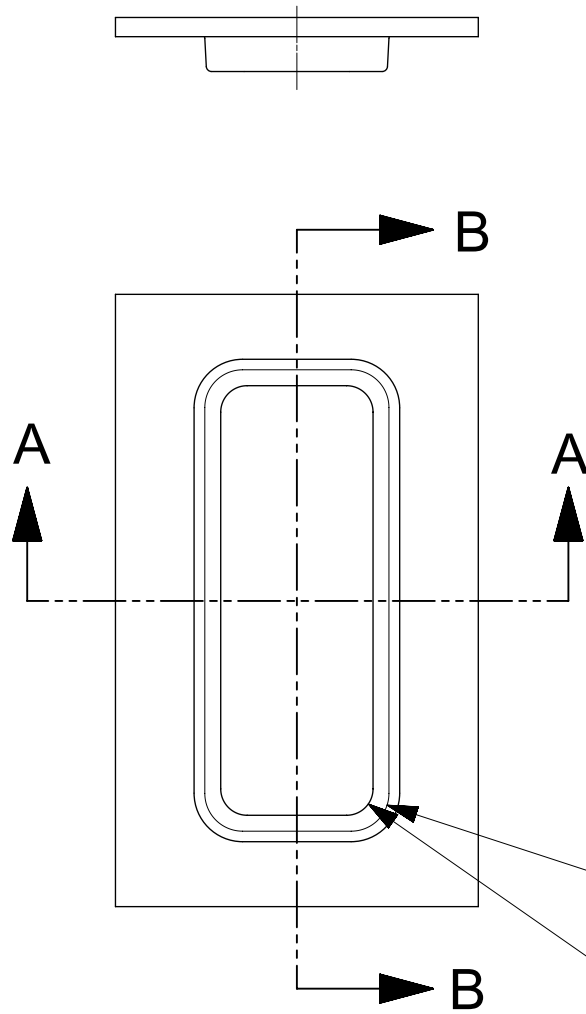
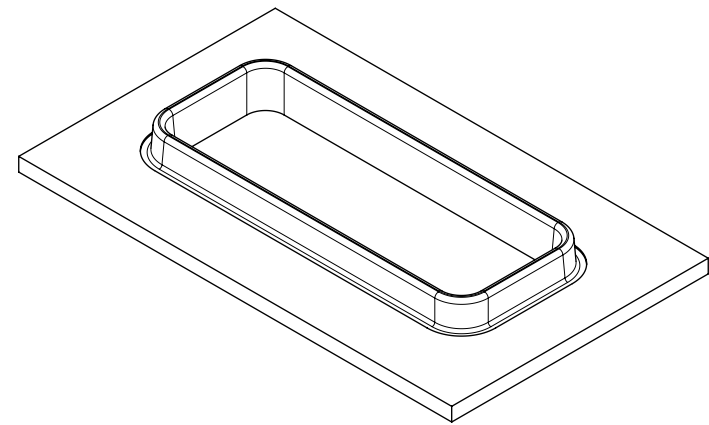

SECTION B-B

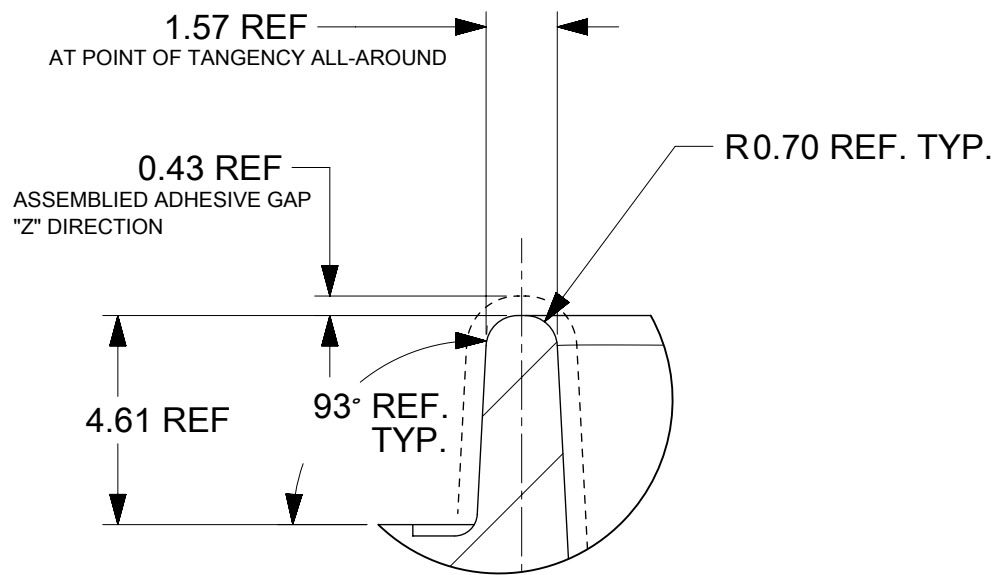

SCALE 6:1

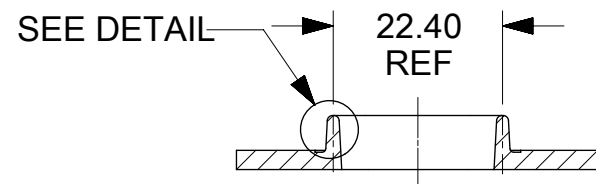

SECTION A-A

R5.00 REF. TYP

R3.50 REF. TYP

THIS DRAWING CONTAINS INFORMATION THAT IS PROPRIETARY TO MOLEX ELECTRONIC TECHNOLOGIES, LLC AND SHOULD NOT BE USED WITHOUT WRITTEN PERMISSION

QUALITY SYMBOLS	EC NO: 121890 DRWN: BSKANTHARAJU CHKD: APPR: DKRAWCZYK	2017/03/28 2017/10/12	GENERAL TOLERANCES (UNLESS SPECIFIED)		DIMENSION UNITS	SCALE		
			ANGULAR TOL ± °		MM	1:1		
▽ = 0	DRAFT WHERE APPLICABLE MUST REMAIN WITHIN DIMENSIONS	B1	4 PLACES ±	DRWN BY	DATE	LARGE FOOTPRINT ADHESIVE TONGUE GEOMETRY		
▽ = 0			3 PLACES ±	FJAKLIC	11/21/2008			
▽ = 0			2 PLACES ±	CHK'D BY	DATE			
▽ = 0			1 PLACE ±	GPRATT	11/21/2008			
▽ = 0			0 PLACES ±	APPR BY	DATE			
▽ = 0			DKRAWCZYK	2013/02/19	PRODUCT CUSTOMER DRAWING			
□ = 0			DRAWING SIZE	THIRD ANGLE PROJECTION	SERIES	MATERIAL NUMBER	CUSTOMER	
■ = 0			B		31387		GENERAL MARKET	
▽ = 0					DOCUMENT NUMBER	DOC TYPE	DOC PART	SHEET NUMBER
					SD-31387-173	PSD	000	1 OF 1

RELEASE STATUS	RELEASE DATE
----------------	--------------